

Second-generation Micro Actuator for Better Head-positioning Accuracy

To increase hard disk drive (HDD) data density, the size of bits – the 1s and 0s that represent the information stored on the disk – decreases and the spacing between their concentric tracks shrinks. As these dimensions shrink, it becomes more difficult to position the read-write head's transducer element over the center of the data track.

Outside disturbances, such as vibrations in the rack in the data center, can cause head-track misalignment. Dual-stage actuators (DSA) have already been implemented to position the read-write head with greater accuracy. Western Digital is now implementing Western Digital Micro Actuator (WDMA), a second-generation dual-stage actuator that enables even better head-positioning accuracy. Western Digital first implemented WDMA in the Ultrastar® DC HC510 hard drive and has included WDMA in the mechanical design of subsequent products because better head-positioning accuracy delivers better performance, data integrity and overall drive reliability.

How it Works

WDMA structure and actuation are shown in Figure 1. Small multi-layer piezos are attached to the flexure. When differential voltage is applied to the WDMA, one piezo element expands as the other contracts. This action causes a slight rotational motion of the read-write head. Since the WDMA's moving portion is so small with lighter mass compared with Milli Actuator (Milli), first-generation DSA, the WDMA element's vibrational resonance frequency is much higher than that of Milli. As a result, the WDMA can rapidly and accurately position the head element over the correct data track.

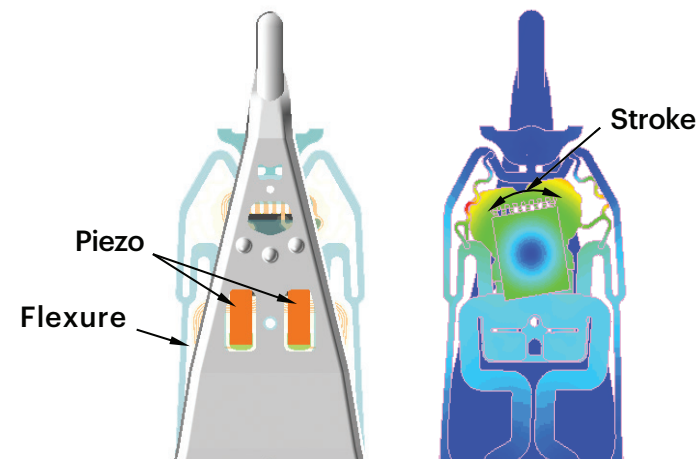

Figure 1. WDMA structure and actuation

The WDMA's transfer function from the drive voltage to the head displacement compared with Milli is shown in Figure 2. Main resonance frequency of WDMA is much higher than that of Milli. This function increases servo bandwidth to a higher frequency range and improves head positioning accuracy.

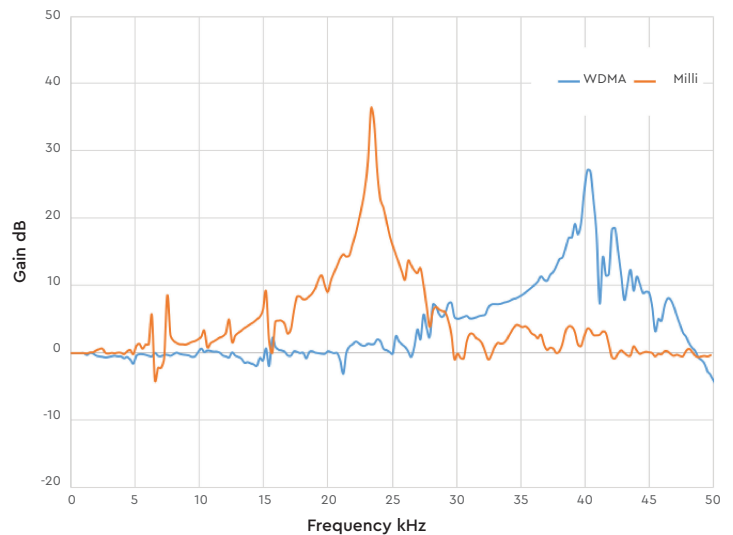

Figure 2. DSA plant transfer function comparison

Figure 3 shows the schematic dual-stage servo block diagram with Voice Coil Motor (VCM) and Micro Actuator (MA). The block diagram consists of VCM, MA, VCM controller and MA controller. "Pv" and "Pm" are the plant of VCM and MA, respectively. The MA controller consists of compensator "Cm" and MA model "Pm0". The signal "pes" represents the position-error signal, and "r" represents track runout. The "vpe" and "mpe" are respectively the position of VCM and MA. Then the overall position "pe" is the sum of "vpe" and "mpe."

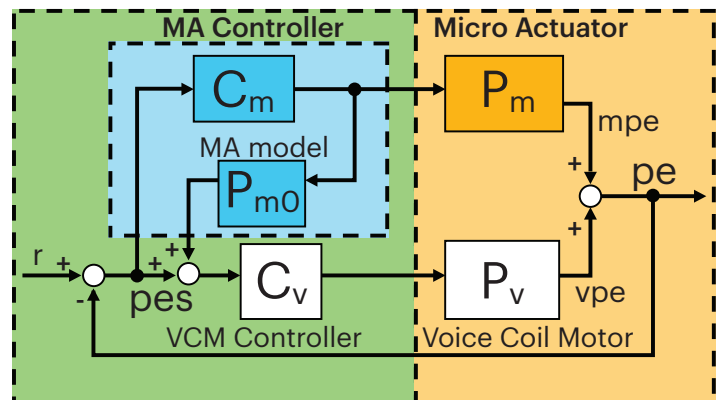

Figure 3. Schematic DSA servo block diagram with VCM and MA

The total dual-stage open loop transfer function from "pes" to "pe" is:

$$G_{ol} = P_m C_m + (1 + P_m O C_m) P_v C_v$$

And the error rejection closed loop transfer function from "r" to "pes" is:

$$G_{err} = 1/(1+G_{ol}) = 1/(1+P_m C_m)(1+P_v C_v) = G_{snsvcm} G_{snsm}, \text{ where } P_m O = P_m$$

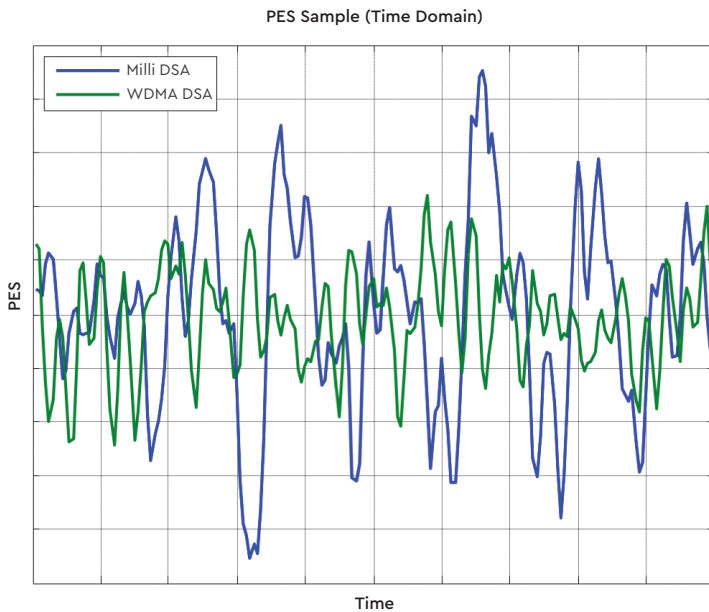

Figure 4. Position-error signal of WDMA DSA compared to Milli DSA

The total error rejection closed loop "Gerr" of the dual-stage servo system is the product of the VCM and MA loop sensitivities, "Gsnsvcm" and "Gsnsm", respectively. Thus, the dual-stage servo control design can be decoupled into two independent controller designs: the VCM loop and the MA loop. Usually, the VCM open loop gain-crossover frequency is limited by the head-stack assembly and suspension resonance modes, and the dual-stage compensator is defined by the design of the MA compensators that attains additional attenuation of "Gsnsm".

Figures 4 and 5 show the position-error signal (pes) comparison between the conventional Milli Actuator (blue) and WDMA (green) DSA systems under an external vibration condition. The green line shows how significantly the WDMA DSA system can reduce the head-positioning error caused by external vibration compared to Milli Actuator DSA system.

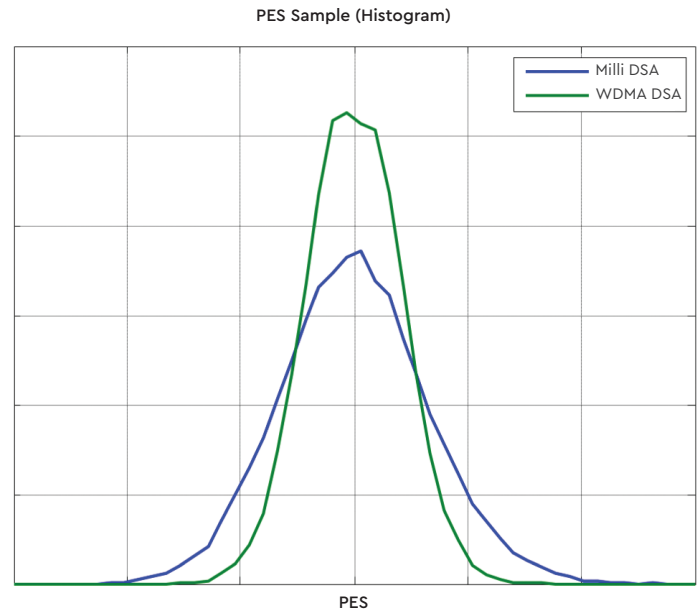

Figure 5. Position-error signal distribution of WDMA DSA compared to Milli DSA

Conclusion

The better WDMA mechanical dynamics enlarges the DSA servo bandwidth and also improves the loop-shaping capability, which lead to a noticeable operational vibration robustness. Being able to keep the head over the data with better accuracy, especially in multi-drive systems where operational vibration is present, ultimately results in better performance, data integrity and overall drive reliability.

To learn more about Western Digital technologies and products, visit www.westerndigital.com.

Western Digital.

5601 Great Oaks Parkway
San Jose, CA 95119, USA
US (Toll-Free): 800.801.4618
International: 408.717.6000

www.westerndigital.com

© 2018 Western Digital Corporation or its affiliates. All rights reserved. Produced 9/18.

Western Digital, the Western Digital logo, HelioSeal and Ultrastar are trademarks or registered trademarks of Western Digital Corporation or its affiliates in the US and/or other countries. The NVMe™ word mark is a trademark of NVM Express, Inc. Apache®, Apache Hadoop, and Hadoop® are either registered trademarks or trademarks of The Apache Software Foundation in the United States and/or other countries. All other marks are the property of their respective owners. One MB is equal to one million bytes, one GB is equal to one billion bytes, one TB equals 1,000GB and one PB equals 1,000TB when referring to HDD/SSD capacity. Accessible capacity will vary from the stated capacity due to formatting and partitioning of the HDD/SSD drive, the computer's operating system, and other factors.