



Hard Disk Drive Specification

HGST Travelstar Z5K500

2.5 inch SATA hard disk drive

Models: HTE545050A7E680

HTE545032A7E680

Revision 4.2

08 January 2015

The 1st Edition (Rev 4.0) (28 March 2014)

The 2nd Edition (Rev 4.1) (22 August 2014)

The 3rd Edition (Rev 4.2) (08 January 2015)

The following paragraph does not apply to the United Kingdom or any country where such provisions are inconsistent with local law: HGST, A WESTERN DIGITAL COMPANY PROVIDES THIS PUBLICATION "AS IS" WITHOUT WARRANTY OF ANY KIND, EITHER EXPRESS OR IMPLIED, INCLUDING, BUT NOT LIMITED TO, THE IMPLIED WARRANTIES OF MERCHANTABILITY OR FITNESS FOR A PARTICULAR PURPOSE. Some states do not allow disclaimer or express or implied warranties in certain transactions, therefore, this statement may not apply to you.

This publication could include technical inaccuracies or typographical errors. Changes are periodically made to the information herein; these changes will be incorporated in new editions of the publication. HGST may make improvements or changes in any products or programs described in this publication at any time.

It is possible that this publication may contain reference to, or information about, HGST products (machines and programs), programming, or services that are not announced in your country. Such references or information must not be construed to mean that HGST intends to announce such HGST products, programming, or services in your country.

Technical information about this product is available by contacting your local HGST representative or on the Internet at <http://www.hgst.com>

HGST may have patents or pending patent applications covering subject matter in this document. The furnishing of this document does not give you any license to these patents.

© Copyright HGST, a Western Digital company

HGST, a Western Digital company
3403 Yerba Buena Road
San Jose, CA 95135
Produced in the United States

1/15

All rights reserved. Travelstar™ is a trademark of HGST, a Western Digital company.

HGST trademarks are authorized for use in countries and jurisdictions in which HGST has the right to use, market and advertise the brands.

Other product names are trademarks or registered trademarks of their respective owners.

One GB is equal to one billion bytes and one TB equals 1,000 GB (one trillion bytes) when referring to hard drive capacity. Accessible capacity will vary from the stated capacity due to formatting and partitioning of the hard drive, the computer's operating system, and other factors.

References in this publication to HGST products, programs or services do not imply that HGST intends to make these available in all countries in which HGST operates.

Product information is provided for information purposes only and does not constitute a warranty.

Information is true as of the date of publication and is subject to change. Actual results may vary. This publication is for general guidance only. Photographs may show design models.

08 January 2015

Table of Contents

1 GENERAL	9
1.1 Introduction	9
1.2 Abbreviations	9
1.3 References	11
1.4 General caution	11
1.5 Hard disk drive handling precautions	11
2 OUTLINE OF THE HARD DISK DRIVE.....	12
PART 1 FUNCTION SPECIFICATION	13
3 FIXED DISK SUBSYSTEM DESCRIPTION	14
3.1 Control Electronics	14
3.2 Head disk assembly data	14
4 FIXED DISK CHARACTERISTICS.....	15
4.1 Formatted capacity by model number.....	15
4.2 Data sheet	15
4.3 Cylinder allocation	16
4.4 Performance characteristics	17
5 DATA INTEGRITY	20
5.1 Data loss on power off	20
5.2 Write Cache	20
5.3 Equipment status	20
5.4 WRITE safety.....	20
5.5 Data buffer test.....	21
5.6 Error recovery.....	21
5.7 Automatic reallocation	21
6 SPECIFICATION	22
6.1 Environment	22
6.2 DC power requirements	24
6.3 Reliability.....	25
6.4 Mechanical specifications.....	28
6.5 Vibration and shock.....	30
6.6 Acoustics	32
6.7 Identification labels.....	33
6.8 Electromagnetic compatibility.....	33
6.9 Safety.....	34
6.10 Packaging.....	34
6.11 Substance restriction requirements	34
7 ELECTRICAL INTERFACE SPECIFICATIONS	35
7.1 Cabling	35
7.2 Interface connector.....	35
7.3 Signal definitions.....	36
PART 2 INTERFACE SPECIFICATION	38
8 GENERAL	39
8.1 Introduction	39
8.2 Terminology	39
9 DEVIATIONS FROM STANDARD	40
10 PHYSICAL INTERFACE.....	40
11 REGISTERS	41
11.1 Register naming convention	41
11.2 Command register	42
11.3 Device Control Register	42
11.4 Device Register	42
11.5 Error Register	43
11.6 Features Register	43
11.7 LBA High Register	43
11.8 LBA Low Register.....	43
11.9 LBA Mid Register.....	43
11.10 Sector Count Register.....	44

11.11	Status Register.....	44
12	GENERAL OPERATION DESCRIPTIONS	45
12.1	Reset Response	45
12.2	Diagnostic and Reset considerations.....	46
12.3	Power-off considerations	47
12.4	Sector Addressing Mode.....	48
12.5	Power Management Feature	49
12.6	Interface Power Management Mode(Slumber and Partial).....	50
12.7	S.M.A.R.T. Function.....	51
12.8	Security Mode Feature Set	53
12.9	Protected Area Function	59
12.10	Write Cache Function.....	62
12.11	Reassign Function.....	62
12.12	48-bit Address Feature Set.....	63
12.13	Software Setting Preservation Feature Set	64
12.14	Native Command Queuing.....	65
12.15	SMART Command Transport (SCT).....	65
12.16	Power-Up In Standby (PUIS) feature set.....	66
12.17	Early Drive Ready (EDR) function	67
13	COMMAND PROTOCOL.....	70
13.1	Data In Commands	70
13.2	Data Out Commands.....	71
13.3	Non-Data Commands	71
13.4	DMA Data Transfer Commands.....	72
13.5	First-parity DMA Commands.....	72
14	COMMAND DESCRIPTIONS	73
14.1	Check Power Mode (E5h/98h).....	77
14.2	Device Configuration Overlay (B1h)	78
14.3	Download Microcode (92h).....	82
14.4	Execute Device Diagnostic (90h)	84
14.5	Flush Cache (E7h).....	85
14.6	Flush Cache Ext (EAh)	86
14.7	Format Track (50h: Vendor Specific)	87
14.8	Format Unit (F7h: Vendor Specific).....	88
14.9	Identify Device (ECh).....	89
14.10	Idle (E3h/97h).....	100
14.11	Idle Immediate (E1h/95h)	101
14.12	Initialize Device Parameters (91h)	102
14.13	Read Buffer (E4h)	103
14.14	Read DMA(C8h/C9h)	104
14.15	Read DMA Ext (25h).....	105
14.16	Read FPDMA Queued (60h).....	106
14.17	Read Log Ext(2Fh).....	107
14.18	Read Log DMA Ext(47h)	115
14.19	Read Multiple (C4h)	116
14.20	Read Multiple Ext (29h)	117
14.21	Read Native Max Address (F8h).....	118
14.22	Read Native Max Address Ext (27h)	119
14.23	Read Sector(s) (20h/21h).....	120
14.24	Read Sector(s) Ext (24h).....	121
14.25	Read Verify Sector(s) (40h/41h)	122
14.26	Read Verify Sector(s) Ext (42h).....	123
14.27	Recalibrate (1xh).....	124
14.28	Security Disable Password (F6h).....	125
14.29	Security Erase Prepare (F3h)	126
14.30	Security Erase Unit (F4h)	127
14.31	Security Freeze Lock (F5h)	128
14.32	Security Set Password (F1h).....	129
14.33	Security Unlock (F2h).....	131
14.34	Seek (7xh).....	132
14.35	Sense Condition (F0h : vendor specific).....	133

14.36	Set Features (EFh).....	134
14.37	Set Max Address (F9h).....	136
14.38	Set Max Address Ext (37h).....	138
14.39	Set Multiple (C6h).....	140
14.40	Sleep (E6h/99h).....	141
14.41	S.M.A.R.T Function Set (B0h).....	142
14.42	Standby (E2h/96h).....	155
14.43	Standby Immediate (E0h/94h).....	156
14.44	Write Buffer (E8h).....	157
14.45	Write DMA (CAh/CBh).....	158
14.46	Write DMA Ext (35h).....	159
14.47	Write DMA FUA Ext (3Dh).....	160
14.48	Write FPDMA Queued (61h).....	161
14.49	Write Log Ext (3Fh).....	162
14.50	Write Log DMA Ext (57h).....	163
14.51	Write Multiple (C5h).....	164
14.52	Write Multiple Ext (39h).....	165
14.53	Write Multiple FUA Ext (CEh).....	166
14.54	Write Sector(s) (30h/31h).....	167
14.55	Write Sector(s) Ext (34h).....	168
14.56	Write Uncorrectable Ext (45h).....	169
15	TIMINGS.....	171

List of Figures

Figure 1 Limits of temperature and humidity	22
Figure 2 Mounting hole locations	28
Figure 3 Interface connector pin assignments	35
Figure 4 Parameter descriptions	37
Figure 5 Initial Setting	54
Figure 6 Usual Operation	55
Figure 7 Password Lost	56
Figure 8 Set Max security mode transition	61
Figure 9 Selective self-test test span example	144

List of Tables

Table 1 Formatted capacity by model number.	15
Table 2 Data sheet	15
Table 3 Cylinder allocation	16
Table 4 Performance characteristics	17
Table 5 Mechanical positioning performance	17
Table 6 Full stroke seek time	18
Table 7 Single track seek time	18
Table 8 Latency time	18
Table 9 Drive ready time	18
Table 10 Operating mode	19
Table 11 Drive ready time	19
Table 12 Environmental condition	22
Table 13 Magnetic flux density limits	23
Table 14 DC Power requirements	24
Table 15 Power consumption efficiency	24
Table 16 Physical dimensions and weight	28
Table 17 Random vibration PSD profile breakpoints (operating)	30
Table 18 Swept sine vibration	30
Table 19 Random Vibration PSD Profile Breakpoints (non-operating)	31
Table 20 Operating shock	31
Table 21 Non-operating shock	31
Table 22 Weighted sound power	32
Table 23 Interface connector pins and I/O signals	36
Table 24 Register naming convention and correspondence	41
Table 25 Device Control Register	42
Table 26 Device Register	42
Table 27 Error Register	43
Table 28 Status Register	44
Table 29 Reset Response Table	45
Table 30 Default Register Values	46
Table 31 Diagnostic Codes	46
Table 32 Reset error register values	46
Table 33 Device's behavior by ATA commands	47
Table 34 Power conditions	50
Table 35 Command table for device lock operation	57
Table 36 Command table for device lock operation - continued	58
Table 37 Set Max Set Password data content	60
Table 38 Preserved Software Setting	64
Table 39 SCT Action Code Supported	65
Table 40 PM4: PUIS command behavior	66
Table 41 Command Type for Early Drive Ready	69
Table 42 Command set	73
Table 43 Command Set - continued	74
Table 44 Command Set (Subcommand)	75
Table 45 Check Power Mode Command (E5h/98h)	77
Table 46 Device Configuration Overlay Command (B1h)	78
Table 47 Device Configuration Overlay Features register values	78
Table 48 Device Configuration Overlay Data structure	80

Table 49 DCO error information definition	81
Table 50 Download Command (92h)	82
Table 51 Execute Device Diagnostic Command (90h)	84
Table 52 Flush Cache Command (E7h)	85
Table 53 Flush Cache EXT Command (EAh)	86
Table 54 Format Track Command (50h)	87
Table 55 Format Unit Command (F7h)	88
Table 56 Identify Device Command (ECh)	89
Table 57 Identify device information	90
Table 58 Identify device information --- Continued ---	91
Table 59 Identify device information --- Continued ---	92
Table 60 Identify device information --- Continued ---	93
Table 61 Identify device information --- Continued ---	94
Table 62 Identify device information --- Continued ---	95
Table 63 Identify device information --- Continued ---	96
Table 64 Identify device information --- Continued ---	97
Table 65 Identify device information --- Continued ---	98
Table 66 Number of cylinders/heads/sectors by models for HTE5450XXA7E680	99
Table 67 Idle Command (E3h/97h)	100
Table 68 Idle Immediate Command (E1h/95h)	101
Table 69 Initialize Device Parameters Command (91h)	102
Table 70 Read Buffer Command (E4h)	103
Table 71 Read DMA Command (C8h/C9h)	104
Table 72 Read DMA Ext Command (25h)	105
Table 73 Read FPDMA Queued Command (60h)	106
Table 74 Read Log Ext Command (2Fh)	107
Table 75 Log address definition	107
Table 76 General purpose Log Directory	108
Table 77 Extended comprehensive SMART error Log	108
Table 78 Extended Error log data structure	109
Table 79 Command data structure	109
Table 80 Error data structure	110
Table 81 Extended Self-test log data structure	111
Table 82 Extended Self-test log descriptor entry	111
Table 83 Command Error information	112
Table 84 Phy Event Counter Identifier	113
Table 85 Phy Event Counter information	114
Table 86 Read Log DMA Ext Command (47h)	115
Table 87 Read Multiple Command (C4h)	116
Table 88 Read Multiple Ext Command (29h)	117
Table 89 Read Native Max Address Command (F8h)	118
Table 90 Read Native Max Address Ext Command (27h)	119
Table 91 Read Sector(s) Command (20h/21h)	120
Table 92 Read Sector(s) Ext Command (24h)	121
Table 93 Read Verify Sector(s) Command (40h/41h)	122
Table 94 Read Verify Sector(s) Ext Command (42h)	123
Table 95 Recalibrate Command (1xh)	124
Table 96 Security Disable Password Command (F6h)	125
Table 97 Password Information for Security Disable Password command	125
Table 98 Security Erase Prepare Command (F3h)	126
Table 99 Security Erase Unit Command (F4h)	127
Table 100 Erase Unit Information	127
Table 101 Security Freeze Lock Command (F5h)	128
Table 102 Security Set Password Command (F1h)	129
Table 103 Security Set Password Information	129
Table 104 Security Unlock Command (F2h)	131
Table 105 Security Unlock Information	131
Table 106 Seek Command (7xh)	132
Table 107 Sense Condition Command (F0h)	133
Table 108 Set Features Command (EFh)	134
Table 109 Set Max Address Command (F9h)	136
Table 110 Set Max Address Ext Command (37h)	138
Table 111 Set Multiple Command (C6h)	140
Table 112 Sleep Command (E6h/99h)	141

Table 113 S.M.A.R.T. Function Set Command (B0h)	142
Table 114 Log sector addresses	144
Table 115 Device Attribute Data Structure	146
Table 116 Individual Attribute Data Structure	147
Table 117 Status Flag Definitions	148
Table 118 Device Attribute Thresholds Data Structure	150
Table 119 Individual Threshold Data Structure	151
Table 120 SMART Log Directory	151
Table 121 S.M.A.R.T. error log sector	152
Table 122 Error log data structure	152
Table 123 Command data structure	152
Table 124 Error data structure	153
Table 125 Self-test log data structure	153
Table 126 Selective self-test log data structure	154
Table 127 S.M.A.R.T. Error Codes	154
Table 128 Standby Command (E2h/96h)	155
Table 129 Standby Immediate Command (E0h/94h)	156
Table 130 Write Buffer Command (E8h)	157
Table 131 Write DMA Command (CAh/CBh)	158
Table 132 Write DMA Ext Command (35h)	159
Table 133 Write DMA FUA Ext Command (3Dh)	160
Table 134 Write FPDMA Queued Command (61h)	161
Table 135 Write Log Ext Command	162
Table 136 Write Log DMA Ext Command	163
Table 137 Write Multiple Command (C5h)	164
Table 138 Write Multiple Ext Command (39h)	165
Table 139 Write Multiple FUA Ext Command (CEh)	166
Table 140 Write Sector(s) Command (30h/31h)	167
Table 141 Write Sector(s) Ext Command (34h)	168
Table 142 Write Uncorrectable Ext Command (45h)	169
Table 143 Timeout Values	171

1 General

1.1 Introduction

This document describes the specifications of the HGST Travelstar Z5K500 2.5-inch hard disk drive with Serial ATA interface:

Drive name	Model Number	Type	Max data transfer rate (Gbps)	Capacity (GB)	Height (mm)	Rotation speed (rpm)
Travelstar Z5K500-500	HTE545050A7E680	TT5SAE500	6.0	500	7	5400
Travelstar Z5K500-320	HTE545032A7E680	TT5SAE320	6.0	320	7	5400

1.2 Abbreviations

Abbreviation	Meaning
32 KB	32 x 1024 bytes
64 KB	64 x 1024 bytes
"	Inch
A	Amp
AC	alternating current
AT	Advanced Technology
ATA	Advanced Technology Attachment
Bels	Unit of sound power
BIOS	Basic Input/Output System
°C	Degrees Celsius
CSA	Canadian Standards Association
C-UL	Canadian-Underwriters Laboratory
Cyl	Cylinder
DC	Direct current
DFT	Drive Fitness Test
DMA	Direct Memory Access
ECC	Error correction code
EEC	European Economic Community
EMC	Electromagnetic compatibility
ERP	Error Recovery Procedure
Esd	Electrostatic discharge
FCC	Federal Communications Commission
FRU	Field replacement unit
G	Gravity, a unit of force
Gb	1 000 000 000 bits
GB	1 000 000 000 bytes
GND	Ground
h	Hexadecimal
HDD	Hard disk drive
Hz	Hertz
I	Input
ILS	Integrated lead suspension
imped	Impedance
I/O	Input/Output
ISO	International Standards Organization
KB	1,000 bytes

Kbit/mm	1,000 bits per mm
Kbit/sq-mm	1000 bits per square mm
KHz	Kilohertz
LBA	logical block addressing
Lw	Unit of A-weighted sound power
m	Meter
max. or Max.	Maximum
MB	1,000,000 bytes
Mbps	1,000,000 Bit per second
Mb/sec	1,000,000 Bit per second
MB/sec	1,000,000 bytes per second
MHz	Mega-hertz
MLC	Machine Level Control
mm	Milli-meter
ms	Milli-second
μs	Micro-second
Nm	Newton meter
No. or #	Number
oct/min	Oscillations per minute
O	Output
OD	Open Drain Programmed Input/Output
PIO	Program I/O
POH	Power on hours
Pop.	Population
P/N	Part number
p-p	Peak-to-peak
PSD	Power spectral density
RES	Radiated electromagnetic susceptibility
RFI	Radio frequency interference
RH	Relative humidity
% RH	Percent relative humidity
RMS	Root mean square
RPM	Revolutions per minute
RST	Reset
R/W	Read/write
sec	Second
Sect/Trk	Sectors per track
SELV	Secondary low voltage
S.M.A.R.T	Self-monitoring, analysis, and reporting technology
Trk.	Track
TTL	Transistor-transistor logic
UL	Underwriters Laboratory
V	Volt
VDE	Verb and Deutscher Electrotechniker
W	Watt
3-state	Transistor-transistor tristate logic

1.3 References

Serial ATA International Organization: Serial ATA Revision 2.6

1.4 General caution

Do not apply force to the top cover (See a figure below).

Do not cover the breathing hole on the top cover (See a figure below).

Do not touch the interface connector pins or the surface of the printed circuit board.

The hard disk drive can be damaged by shock or ESD (Electric Static Discharge). Any damages incurred to the hard disk drive after removing it from the shipping package and the ESD protective bag are the responsibility of the user

1.5 Hard disk drive handling precautions

Do not press!

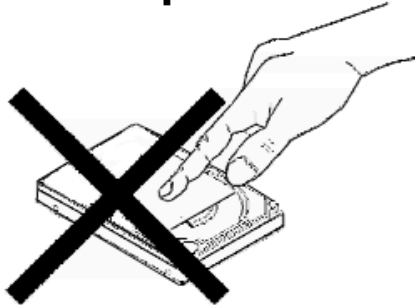

Do not press on the hard disk drive cover during handling.

Do not cover this hole

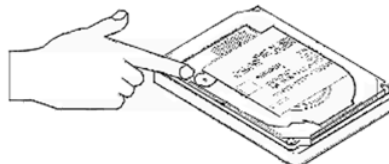

Covering this hole will result in loss of data

2 Outline of the hard disk drive

- 2.5-inch, 7 mm Height
- Perpendicular Recording
- Formatted capacities of 500GB, 320GB (4kB/sector,512B emulation)
- SATA Interface conforming to Serial ATA International Organization: Serial ATA Revision 2.6(15-February-2007)
- Enhanced Availability feature: 732 hour POH monthly with continuous operation Ambient Temperature ; 0 to 60'
- Integrated controller
- No-ID recording format
- Multi zone recording
- Segmented Buffer with write cache
 - 8192 KB - A portion of buffer capacity used for firmware
- Fast data transfer rate
- Media data transfer rate (max):
 - 1004 Mb/s
- Average seek time: 13 ms for read
- Closed-loop actuator servo (Embedded Sector Servo)
- Rotary voice coil motor actuator
- Load/Unload mechanism
- Mechanical latch
- Power on to ready
 - 3.5 sec

Part 1 Function Specification

3 Fixed disk subsystem description

3.1 Control Electronics

The control electronics works with the following functions:

- SATA Interface Protocol
- Embedded Sector Servo
- No-ID (TM) formatting
- Multi-zone recording
- System ECC

3.2 Head disk assembly data

The following technologies are used in the hard disk drive:

- Femto Slider
- Perpendicular recording disk and write head
- TMR head
- Integrated lead suspension (ILS)
- Load/unload mechanism
- Mechanical latch

4 Fixed disk characteristics

4.1 Formatted capacity by model number

Description	500GB	320GB
Physical Layout		
Bytes per Sector	4k	4k
Number of Heads	2	2
Number of Disks	1	1
Logical Layout		
Number of Heads	16	16
Number of Sectors/ Track	63	63
Number of Cylinders	16,383	16,383
Number of Sectors	976,773,168	625,142,448
Total Logical Data Bytes	500,107,862,016	320,072,933,376

Table 1 Formatted capacity by model number.

4.2 Data sheet

	500GB	320GB
Rotational Speed (RPM)	5400	5400
Data transfer rates (buffer to/from media) (Mbps)	1004	897
Data transfer rates (Gbit/sec)	6.0	6.0
Recording density (Kbit/mm (Max)) (KBPI (Max))	66.0 1677	58.5 1485
Track density (Ktrack/mm (Max)) (KTPI (Max))	14.8 376	11.1 283
Areal density (Gbit/sq-mm (Max)) (Gbit/sq-inch (Max))	0.977 630	0.651 420
Number of zones	30	30

Table 2 Data sheet

4.3 Cylinder allocation

Data format is allocated by each head characteristics. Typical format is described below.

500GB/p Mid BPI-Mid TPI format				
Zone	Cylinder			No. of Sectors/Trk
0	0	-	11374	316
1	11375	-	22499	316
2	22500	-	33374	299
3	33375	-	44124	295
4	44125	-	54624	288
5	54625	-	64874	288
6	64875	-	74999	280
7	75000	-	84874	279
8	84875	-	94499	273
9	94500	-	103999	264
10	104000	-	113249	256
11	113250	-	122249	248
12	122250	-	131124	246
13	131125	-	139749	237
14	139750	-	148124	231
15	148125	-	156374	231
16	156375	-	164374	228
17	164375	-	172124	220
18	172125	-	179624	220
19	179625	-	186999	211
20	187000	-	194124	207
21	194125	-	200999	203
22	201000	-	207749	198
23	207750	-	214249	192
24	214250	-	220499	186
25	220500	-	226624	181
26	226625	-	232499	176
27	232500	-	238124	176
28	238125	-	243624	168
29	243625	-	248874	162

Table 3 Cylinder allocation

4.4 Performance characteristics

Hard disk drive performance is characterized by the following parameters:

- Command Overhead
- Mechanical Positioning
 - ◆ Seek Time
 - ◆ Latency
- Data Transfer Speed
- Buffering Operation (Look ahead/Write Cache)

Note: All the above parameters contribute to the hard disk drive performance. There are other parameters which contribute to the performance of the actual system. This specification defines the essential characteristics of the hard disk drives. This specification does not include the system throughput as this is dependent upon the system and the application.

The following table gives a typical value for each parameter.

Function	
Average Random Seek Time – Read/Write (ms)	13
Rotational Speed (RPM)	5400
Power-on-to-ready (sec)	3.5
Disk-buffer data transfer (Mb/s) (max)	1004
Buffer-host data transfer (Gbit/s) (max)	6.0

Table 4 Performance characteristics

4.4.1 Mechanical positioning

4.4.1.1 Average seek time (including settling)

Command Type	Typical (ms)	Max. (ms)
Read/Write	13	18

Table 5 Mechanical positioning performance

Typical and Max. are defined as followings:

Typical Average of the hard disk drive population tested at nominal environmental and voltage conditions.

Max. Maximum value measured on any hard disk drive over the full range of the environmental and voltage conditions. (See section 6.1, "Environment" and section 6.2, "DC power requirements")

The seek time is measured from a start of motion of an actuator to the start of a reliable read or write operation. A reliable read or write operation implies that error correction/recovery is not employed to correct arrival problems. The Average Seek Time is measured as the weighted average of all possible seek combinations.

$$\text{Weighted Average} = \frac{\sum_{n=1}^{\text{max.}} (\text{max.} + 1 - n)(T_{n\text{in}} + T_{n\text{out}})}{(\text{max.} + 1)(\text{max.})}$$

Where: max. = maximum seek length

n = seek length (1-to-max.)

T_{nin} = inward measured seek time for an n-track seek

T_{nout} = outward measured seek time for an n-track seek

4.4.1.2 Full stroke seek

Command Type	Typical (ms)	Max. (ms)
Read	25.0	30.0
Write	25.0	30.0

Table 6 Full stroke seek time

Full stroke seek time in milli-seconds is the average time of 1000 full stroke seeks.

4.4.1.3 Single track seek time (without command overhead, including settling)

Command Type	Typical (ms)	Maximum (ms)
Read	1.0	2.0
Write	1.1	2.2

Table 7 Single track seek time

Single track seek is measured as the average of one (1) single track seek from every track in both directions (inward and outward).

4.4.1.4 Average latency

Rotational Speed (RPM)	Time for one revolution (ms)	Average Latency (ms)
5400	11.1	5.5

Table 8 Latency time

4.4.1.5 Drive ready time

Condition	Typical (sec)	Max. (sec)
Power On To Ready	3.5	6.0

Table 9 Drive ready time

- Ready** The condition in which the hard disk drive is able to perform a media access command (for example—read, write) immediately.
- Power On To Ready** This includes the time required for the internal self diagnostics.

4.4.2 Operating modes

Operating mode	Description
Spin-Up	Start up time period from spindle stop or power down.
Seek	Seek operation mode
Write	Write operation mode
Read	Read operation mode
Performance idle	The device is capable of responding immediately to media access requests. All electronic components remain powered and the full frequency servo remains operational.
Standby	The device interface is capable of accepting commands. The spindle motor is stopped. All circuitry but the host interface is in power saving mode. An execution of a command is delayed until the spindle gets ready.
Sleep	The device requires a soft reset or a hard reset to be activated. All electronics, including a spindle motor and the host interface, are shut off.

Table 10 Operating mode

4.4.2.1 Mode transition time

From	To	Transition Time (typ)	Transition Time (max.)
Standby	Idle	2.5	6.0

Table 11 Drive ready time

4.4.2.2 Operating mode at power on

The device goes into Idle mode after power on or hard reset as an initial state.

5 Data integrity

5.1 Data loss on power off

- Data loss will not be caused by a power off during any operation except write operation.
- A power off during a write operation causes the loss of any received or resident data that has not been written onto disk media.
- A power off during a write operation might make a maximum of one sector of data unreadable. This state can be recovered by a rewrite operation.

5.2 Write Cache

When the write cache is enabled, write commands may complete before the actual disk write operation finishes. This means that a power off, even after the write command completion, could cause a loss of data that the hard disk drive has received but not yet written onto a disk.

In order to prevent this data loss, confirm the completion of the actual write operation prior to the power off by issuing one of the following operation.

- Soft reset
- Hard reset
- Flush Cache command
- Standby command
- Standby Immediate command
- Sleep command

Confirm the command's completion.

5.3 Equipment status

The equipment status is available to the host system any time the hard disk drive is not ready to read, write, or seek. This status normally exists at the power-on time and will be maintained until the following conditions are satisfied:

- The access recalibration/tuning is complete.
- The spindle speed meets the requirements for reliable operation.
- The self-check of the hard disk drive is complete.

The appropriate error status is made available to the host system if any of the following conditions occur after the hard disk drive has become ready:

- The spindle speed lies outside the requirements for reliable operation.
- The occurrence of a Write Fault condition.

5.4 WRITE safety

The hard disk drive ensures that data is written into disk media properly. The following conditions are monitored during a write operation. When one of these conditions exceeds the criteria, the write operation is terminated and the automatic retry sequence is invoked.

- Head off track
- External shock
- Low supply voltage
- Spindle speed out of tolerance
- Head open/short

5.5 Data buffer test

The data buffer is tested at power on reset and when the hard disk drive self-test is requested by the host. The test consists of a write/read '00'x and 'ff'x pattern on all buffers.

5.6 Error recovery

Errors occurring on the hard disk drive are handled by the error recovery procedure.

Errors that are uncorrectable after application of the error recovery procedure are reported to the host system as non-recoverable errors.

5.7 Automatic reallocation

The sectors that show some errors may be reallocated automatically when specific conditions are met. The hard disk drive does not report any auto reallocation to the host system. The conditions for auto reallocation are described below.

5.7.1 Non-recovered write errors

When a write operation cannot be completed after the Error Recovery Procedure (ERP) is fully carried out, the sectors are reallocated to spare location. An error is reported to the host system only when the write cache is disabled and the auto reallocation has failed.

5.7.2 Non-recoverable read error

When a read operation fails after ERP is fully carried out, a hard error is reported to the host system. This location is registered internally as a candidate for the reallocation. When a registered location is specified as a target of a write operation, a sequence of media verification is performed automatically. When the result of this verification meets the required criteria, this sector is reallocated.

5.7.3 Recovered read errors

When a read operation for a sector fails and is recovered at the specific ERP step, the sector is reallocated automatically. A media verification sequence may be run prior to the reallocation according to predefined conditions.

6 Specification

6.1 Environment

6.1.1 Temperature and humidity

Operating conditions	
Temperature	0 to 60°C (See note below)
Relative humidity	8 to 90% non-condensing
Maximum wet bulb temperature	29.4°C non-condensing
Maximum temperature gradient	20°C/hour
Altitude	-300 to 3048 m (10,000 ft)
Non-operating conditions	
Temperature	-40 to 65°C
Relative humidity	5 to 95% non-condensing
Maximum wet bulb temperature	40°C non-condensing
Maximum temperature gradient	20°C/hour
Altitude	-300 to 12,192 m (40,000 ft)

Table 12 Environmental condition

The system is responsible for providing sufficient air movement to maintain surface temperatures below 60°C at the center of top cover and below 63°C at the center of the hard disk drive circuit board assembly.

The maximum storage period in the shipping package is one year.

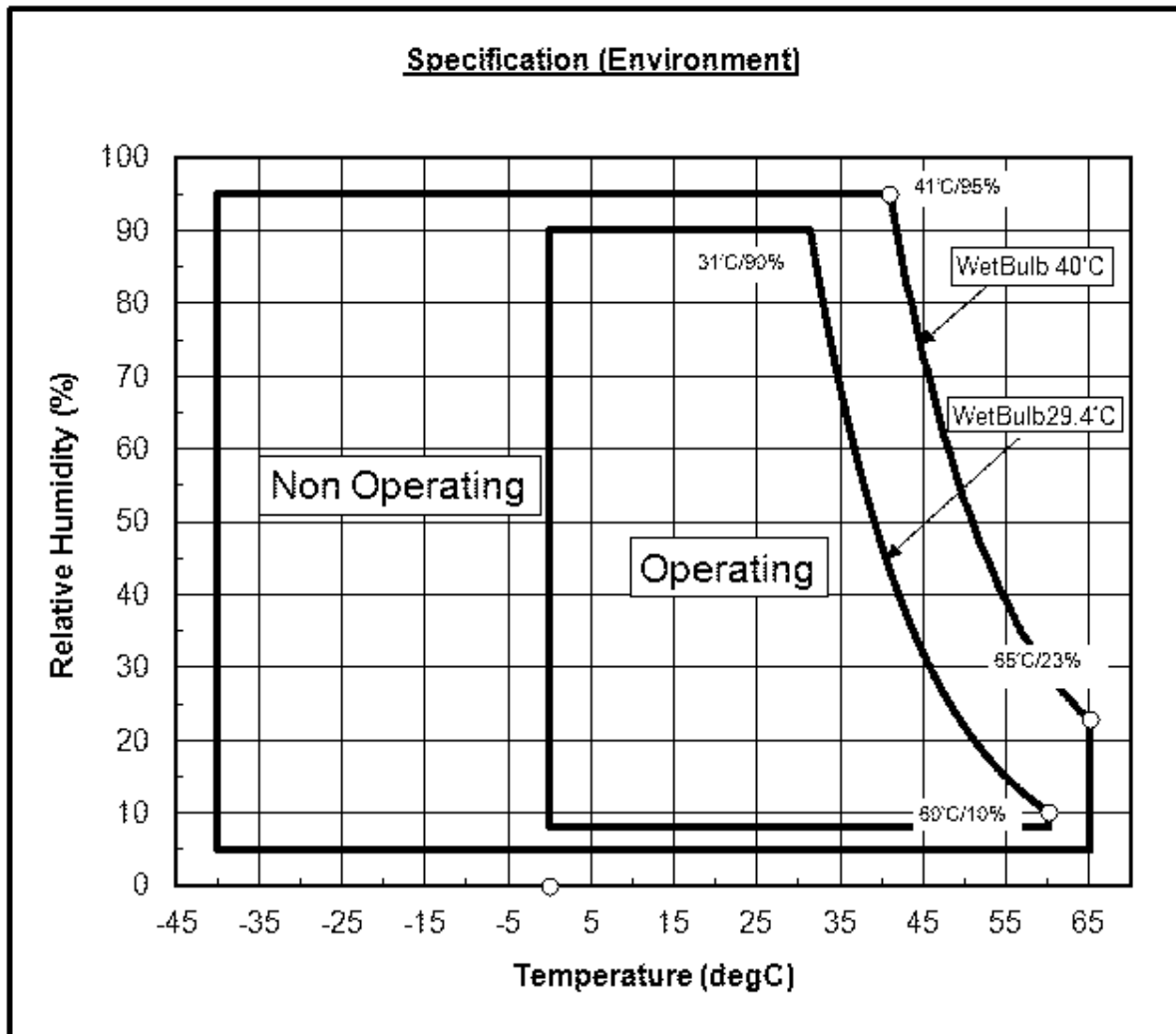

Figure 1 Limits of temperature and humidity

6.1.2 Corrosion test

The hard disk drive must be functional and show no signs of corrosion after being exposed to a temperature humidity stress of 50°C/90%RH (relative humidity) for one week followed by a temperature and humidity drop to 25°C/40%RH in 2 hours.

6.1.3 Radiation noise

The hard disk drive shall work without degradation of the soft error rate under the following magnetic flux density limits at the enclosure surface.

Frequency (KHz)	Limits (uT RMS)
DC	1500 0-p
0 < Frequency =< 60	500 RMS
60 < Frequency =<100	250 RMS
100 < Frequency =< 200	100 RMS
200 < Frequency =< 400	50 RMS

Table 13 Magnetic flux density limits

6.1.4 Conductive noise

The hard disk drive shall work without soft error degradation in the frequency range from DC to 20 MHz injected through any two of the mounting screw holes of the hard disk drive when an AC current of up to 45 mA (p-p) is applied through a 50-ohm resistor connected to any two mounting screw holes.

6.1.5 Atmospheric condition

"Environments that contain elevated levels of corrosives (e.g. hydrogen sulfide, sulfur oxides, or hydrochloric acid) should be avoided. Care must be taken to avoid using any compound/material in a way that creates an elevated level of corrosive materials in the atmosphere surrounding the disk drive. Care must also be taken to avoid use of any organometallic (e.g. organosilicon or organotin) compound/material in a way that creates elevated vapor levels of these compounds/materials in the atmosphere surrounding the disk drive."

6.2 DC power requirements

Connection to the product should be made in a safety extra low voltage (SELV) circuits. The voltage specifications are applied at the power connector of the hard disk drive.

Item	Requirements
Nominal supply	+5 Volt dc
Supply voltage	-0.3 Volt to 6.0 Volt
Power supply ripple (0–20 MHz) ¹	100 mV p-p max.
Tolerance ²	±5%
Supply rise time	1–100 ms

Watts (RMS Typical) ⁷	
Performance Idle average ³	1.5
Read average ⁴	1.6
Write average	1.6
Seek average ⁵	1.8
Standby	0.2
Sleep	0.1
Startup (maximum peak) ⁶	4.5
Average from power on to ready	3.0

Table 14 DC Power requirements

Footnotes:

1. The maximum fixed disk ripple is measured at the 5 volt input of the hard disk drive.
2. The hard disk drive shall not incur damage for an over voltage condition of +25% (maximum duration of 20 ms) on the 5 volt nominal supply.
3. The idle current is specified at an inner track.
4. The read/write current is specified based on three operations of 64 sector read/write per 100 ms.
5. The seek average current is specified based on three operations per 100 ms.
6. The worst case operating current includes motor surge.
7. "Typical" mean average of the hard disk drive population tested at nominal environmental and voltage conditions.

6.2.1 Power consumption efficiency

Capacity	500GB	320GB
Power Consumption Efficiency (Watts/GB)	0.003	0.0047

Table 15 Power consumption efficiency

Note: Power consumption efficiency is calculated as Power Consumption of Performance Idle Watt/ Capacity (GB).

6.3 Reliability

6.3.1 Data reliability

- Probability of not recovering data is 1 in 10^{14} bits read

6.3.2 Failure prediction (S.M.A.R.T.)

The hard disk drive supports Self-monitoring, analysis and reporting technology (S.M.A.R.T.) function.

6.3.3 Cable noise interference

To avoid any degradation of performance throughput or error when the interface cable is routed on top or comes in contact with the HDA assembly, the hard disk drive must be grounded electrically to the system frame by four screws. The common mode noise or voltage level difference between the system frame and power cable ground or AT interface cable ground should be in the allowable level specified in the power requirement section.

6.3.4 Service life and usage condition

The hard disk drive is designed to be used under the following conditions:

- The hard disk drive should be operated within specifications of shock, vibration, temperature, humidity, altitude, and magnetic field.
- The hard disk drive should be protected from ESD.
- The breathing hole in the top cover of the hard disk drive should not be covered.
- Force should not be applied to the cover of the hard disk drive.
- The specified power requirements of the hard disk drive should be satisfied.
- The hard disk drive frame should be grounded electrically to the system through four screws.
- The hard disk drive should be mounted with the recommended screw depth and torque.
- The interface physical and electrical requirements of the hard disk drive should satisfy Serial ATA Revision 2.6.
- The power-off sequence of the hard disk drive should comply with the 6.3.6.2, "Required power-off sequence."

Service life of the hard disk drive is approximately 5 years or 30,000 power on hours, whichever comes first, under the following assumptions:

- Less than 732 power on hours per month.
- Seeking/Writing/Reading operation is less than 50% of power on hours.

This does not represent any warranty or warranty period. Applicable warranty and warranty period are covered by the purchase agreement.

6.3.5 Preventive maintenance

None.

6.3.6 Load/unload

The product supports a minimum of 600,000 normal load/unloads.

Load/unload is a functional mechanism of the hard disk drive. It is controlled by the hard disk drive micro code. Specifically, unloading of the heads is invoked by the following commands:

- Standby
- Standby immediate
- Sleep

Load/unload is also invoked as one of the idle modes of the hard disk drive.

The specified start/stop life of the product assumes that load/unload is operated normally, not in emergency mode.

6.3.6.1 Emergency unload

When a power is interrupted while the heads are still loaded, the micro code cannot operate and the normal 5-volt power is unavailable to unload the heads. In this case, normal unload is not possible. The heads are unloaded by routing the back EMF of the spinning motor to the voice coil. The actuator velocity is greater than the normal case and the unload process is inherently less controllable without a normal seek current profile.

Emergency unload is intended to be invoked in rare situations. Because this operation is inherently uncontrolled, it is more mechanically stressful than a normal unload.

The hard disk drive supports a minimum of 20,000 emergency unloads.

6.3.6.2 Required Power-Off Sequence

The required host system sequence for removing power from the hard disk drive is as follows:

- Step 1: Issue one of the following commands.
 - Standby
 - Standby immediate
 - Sleep

Note: Do not use the Flush Cache command for the power off sequence because this command does not invoke Unload.

- Step 2: Wait until the Command Complete status is returned.

The host system time out value needs to be 30 seconds considering error recovery time.

- Step 3: Terminate power to hard disk drives.

This power-down sequence should be followed for entry into any system power-down state, system suspend state, or system hibernation state. In a robustly designed system, emergency unload is limited to rare scenarios, such as battery removal during operation.

6.3.6.3 Power switch design considerations

In systems that use the Travelstar Z5K500 consideration should be given to the design of the system power switch.

HGST recommends that the switch operate under control of the host system, as opposed to being hardwired. The same recommendation is made for cover-close switches. When a hardwired switch is turned off, emergency unload occurs, as well as the problems cited in section 5.1, "Data loss by power off" and section 5.2, "Write Cache".

6.3.6.4 Test considerations

Start/stop testing is classically performed to verify head/disk durability. The heads do not land on the disk, so this type of test should be viewed as a test of the load/unload function.

Start/Stop testing should be done by commands through the interface, not by power cycling of the hard disk drive. Simple power cycling of the hard disk drive invokes the emergency unload mechanism and subjects the HDD to non-typical mechanical stress.

Power cycling testing may be required to test the boot-up function of the system. In this case HGST recommends that the power-off portion of the cycle contain the sequence specified in section 6.3.6.2, "Required Power-Off Sequence". If this is not done, the emergency unload function is invoked and non-typical stress results are made.

6.4 Mechanical specifications

6.4.1 Physical dimensions and weight

The following figure lists the dimensions for the hard disk drive.

Model	Height (mm)	Width (mm)	Length (mm)	Weight (gram)
500GB, 320GB models	6.8±0.2	69.85±0.25	100.2±0.25	95 Max

Table 16 Physical dimensions and weight

6.4.2 Mounting hole locations

The mounting hole locations and size of the hard disk drive are shown below.

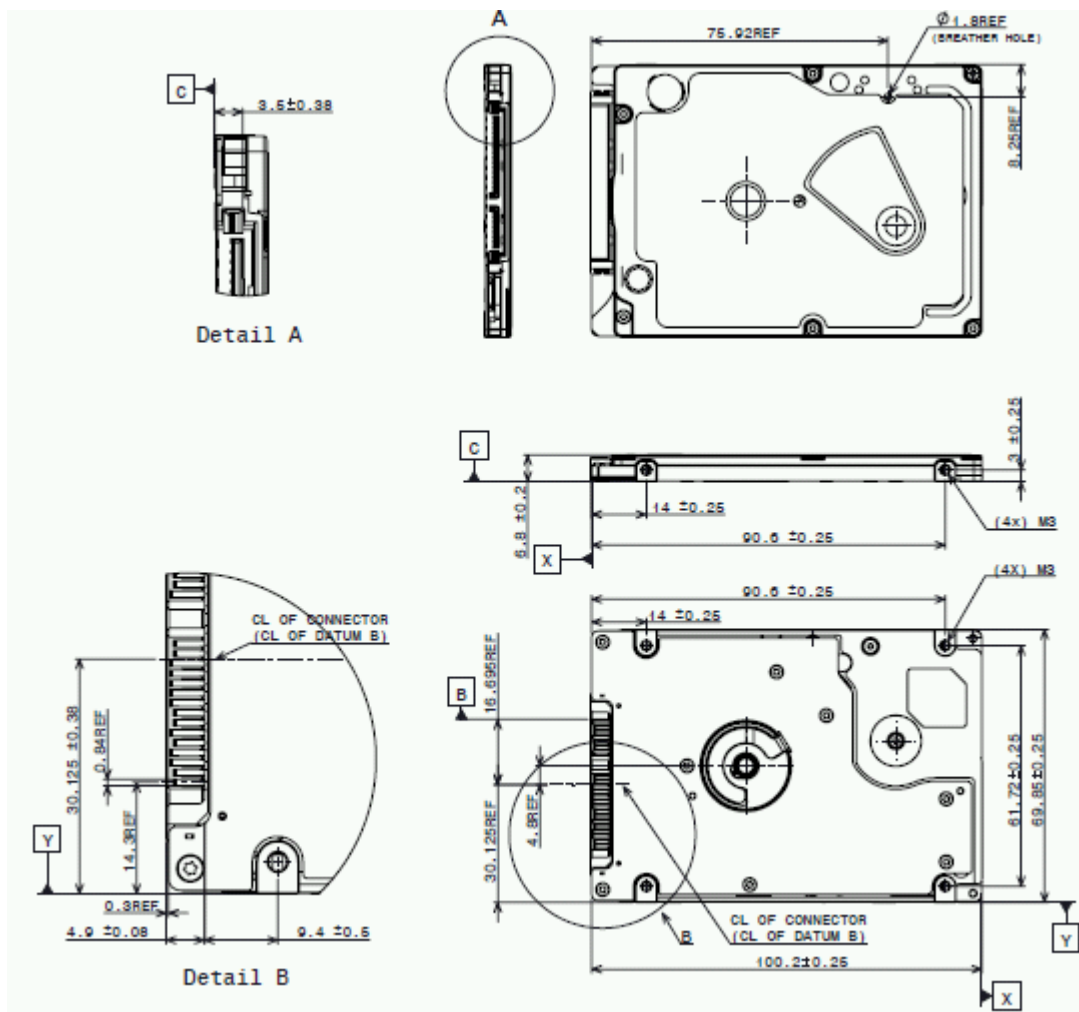

Figure 2 Mounting hole locations

6.4.3 Connector description

Connector specifications are included in section 7.2, "Interface connector".

6.4.4 Mounting orientation

The hard disk drive will operate in all axes (six directions) and will stay within the specified error rates when tilted ± 5 degrees from these positions.

Performance and error rate will stay within specification limits if the hard disk drive is operated in the other permissible orientations from which it was formatted. Thus a hard disk drive formatted in a horizontal orientation will be able to run vertically and vice versa.

The recommended mounting screw torque is 0.3 ± 0.05 Nm.

The recommended mounting screw depth is 3.0 ± 0.3 mm for bottom and 3.5 ± 0.5 mm for horizontal mounting.

The user is responsible for using the appropriate screws or equivalent mounting hardware to mount the hard disk drive securely enough to prevent excessive motion or vibration at seek operation or spindle rotation.

6.4.5 Load/unload mechanism

The head load/unload mechanism is provided to protect the disk data during shipping, movement, or storage. Upon power down, a head unload mechanism secures the heads at the unload position. See section 6.5.4, "Non-operating shock" for additional details.

6.5 Vibration and shock

All vibration and shock measurements in this section are for hard disk drives without mounting attachments for systems. The input level shall be applied to the normal mounting points.

Vibration tests and shock tests are to be conducted by mounting the hard disk drive to a table using the bottom or side four mounting holes.

6.5.1 Operating vibration

The hard disk drive will operate without a hard error while being subjected to the following vibration levels.

6.5.1.1 Random vibration

The test consists of 30 minutes of random vibration using the power spectral density (PSD) levels below. The vibration test level is 6.57m/sec² RMS (Root Mean Square) (0.67 G RMS).

Random vibration PSD profile Breakpoint	
Hz	m x 10n (m ² /sec ⁴)/Hz
5	1.9 x E-3
17	1.1 x E-1
45	1.1 x E-1
48	7.7 x E-1
62	7.7 x E-1
65	9.6 x E-2
150	9.6 x E-2
200	4.8 x E-2
500	4.8 x E-2

Table 17 Random vibration PSD profile breakpoints (operating)

6.5.1.2 Swept sine vibration

Swept sine vibration (zero to peak 5 to 500 to 5 Hz sine wave)	Sweep rate (oct/min)
9.8 m/sec ² (1 G) (5-500 Hz)	1.0

Table 18 Swept sine vibration

6.5.2 Non-operating vibration

The hard disk drive withstands the following vibration levels without any loss or permanent damage.

6.5.2.1 Random vibration

The test consists of a random vibration applied in each of three mutually perpendicular axes for a duration of 15 minutes per axis. The PSD levels for the test simulating the shipping and relocation environment is shown below.

Hz	(m ² /sec ⁴)/Hz
2.5	0.096
5	2.88
40	1.73
500	1.73

Table 19 Random Vibration PSD Profile Breakpoints (non-operating)

Note: Overall RMS level of vibration is 29.50 m/sec² (3.01 G).

6.5.2.2 Swept sine vibration

- 49 m/sec² (5 G) (zero-to-peak), 10 to 500 to 10 Hz sine wave
- 0.5 oct/min sweep rate
- 25.4 mm (peak-to-peak) displacement, 5 to 10 to 5 Hz

6.5.3 Operating shock

The hard disk drive meets the criteria in the table below while operating under these conditions:

- The shock test consists of 10 shock inputs in each axis and direction for a total of 60.
- There must be a minimum delay of 3 seconds between shock pulses.
- The hard disk drive will operate without a hard error while subjected to the following half-sine shock pulse.

Duration of 1 ms	Duration of 2 ms
2205 m/sec ² (225 G)	3920 m/sec ² (400 G)

Table 20 Operating shock

The input level shall be applied to the normal hard disk drive subsystem mounting points used to secure the hard disk drive in a normal system.

6.5.4 Non-operating shock

The hard disk drive withstands the following half-sine shock pulse without any data loss or permanent damage.

Duration of 1 ms	Duration of 11 ms
9800 m/sec ² (1000 G)	1470 m/sec ² (150 G)

Table 21 Non-operating shock

The shocks are applied for each direction of the hard disk drive for three mutually perpendicular axes, one axis at a time. Input levels are measured on a base plate where the hard disk drive is attached with four screws.

6.6 Acoustics

6.6.1 Sound power level

The criteria of A-weighted sound power level are described below.

Measurements are to be taken in accordance with ISO 7779. The mean of the sample of 40 hard disk drives is to be less than the typical value. Each hard disk drive is to be less than the maximum value. The hard disk drives are to meet this requirement in both board down orientations.

A-weighted Sound Power	Typical (Bels)	Maximum (Bels)
Idle	1.9	2.2
Operating	2.1	2.4

Table 22 Weighted sound power

The background power levels of the acoustic test chamber for each octave band are to be recorded.

Sound power tests are to be conducted with the hard disk drive supported by spacers so that the lower surface of the hard disk drive is located 25 ± 3 mm above from the chamber floor. No sound absorbing material shall be used.

The acoustical characteristics of the hard disk drive are measured under the following conditions:

Mode definitions

- Idle mode: Power on, disks spinning, track following, unit ready to receive and respond to control line commands.
- Operating mode: Continuous random cylinder selection and seek operation of the actuator with a dwell time at each cylinder. The seek rate can be calculated as shown below.

$$N_s = 0.4 / (T_t + T_1)$$

where:

N_s = average seek rate in seeks/s

T_t = published seek time from one random track to another without including rotational latency

T_1 = equivalent time in seconds for the hard disk drive to rotate by half a revolution

6.6.2 Discrete tone penalty

Discrete tone penalties are added to the A-weighted sound power (L_w) with the following formula only when determining compliance.

$$L_{wt(spec)} = L_w = 0.1P_t + 0.3 < 4.0 \text{ (Bels)}$$

where

L_w = A-weighted sound power level

P_t = Value of discrete tone penalty = $dL_t - 6.0$ (dBA)

dL_t = Tone-to-noise ratio taken in accordance with ISO 7779 at each octave band.

6.7 Identification labels

The following labels are affixed to every hard disk drive:

- A label which is placed on the top of the head disk assembly containing the statement "Made by HGST" or equivalent, part number.
- A bar code label which is placed on the hard disk drive based on user request. The location on the hard disk drive is to be designated in the drawing provided by the user.
- Labels containing the vendor's name, hard disk drive model number, serial number, place of manufacture, and UL/CSA logos.

6.8 Electromagnetic compatibility

When installed in a suitable enclosure and exercised with a random accessing routine at maximum data rate, the hard disk drive meets the following worldwide electromagnetic compatibility (EMC) requirements:

- United States Federal Communications Commission (FCC) Rules and Regulations (Class B), Part 15. RFI Suppression German National Requirements
- RFI Japan VCCI, Requirements of HGST products
- EU EMC Directive, Technical Requirements and Conformity Assessment Procedures

6.8.1 CE Mark

The product is certified for compliance with EC directive 2004/108/EC. The EC marking for the certification appears on the hard disk drive.

6.8.2 C-Tick Mark

The product complies with the Australian EMC standard "Limits and methods of measurement of radio disturbance characteristics of information technology equipment, AS/NZS 3548:1995 Class B."

6.8.3 BSMI Mark

The product complies with the Taiwan EMC standard "Limits and methods of measurement of radio disturbance characteristics of information technology equipment, CNS 13438 (C6357)"

6.8.4 KC Mark

The product complies with the Korea EMC standard. The regulation for certification of information and communication equipment is based on "Telecommunications Basic Act" and "Radio Waves Act" Korea EMC requirement are based technically on CISPR22 measurement standards and limits. KC standards are likewise based on IEC standards.

6.9 Safety

6.9.1 UL and CSA approval

All models of the Travelstar Z5K500 are qualified per UL60950-1: 2nd edition (2007-03-27),

CSA C22.2 No.60950-1-07:2nd edition (2007-03)

6.9.2 IEC compliance

All models of the Travelstar Z5K500 comply with IEC 60950-1: 2005 (2nd edition).

6.9.3 German Safety Mark

All models of the Travelstar Z5K500 are approved by TUV on Test Requirement: EN 60950-1:2006+A11,, but the GS mark has not been obtained.

6.9.4 Flammability

The printed circuit boards used in this product are made of material with a UL recognized flammability rating of V-1 or better. The flammability rating is marked or etched on the board. All other parts not considered electrical components are made of material with a UL recognized flammability rating of V-1 or better except minor mechanical parts.

6.9.5 Secondary circuit protection

This product utilizes printed circuit wiring that must be protected against the possibility of sustained combustion due to circuit or component failures as defined in C-B 2-4700-034 (Protection Against Combustion). Adequate secondary over current protection is the responsibility of the using system.

The user must protect the hard disk drive from its electrical short circuit problem. A 10 amp limit is required for safety purpose.

6.10 Packaging

The hard disk drive is packed in ESD protective bags and shipped in appropriate containers.

6.11 Substance restriction requirements

The hard disk drive complies with the Directive 2002/95/EC of the European Parliament on the restrictions of the use of the certain hazardous substances in electrical and electronic equipment (RoHS).

7 Electrical interface specifications

7.1 Cabling

The maximum cable length from the host system to the hard disk drive plus circuit pattern length in the host system shall not exceed 1 meter.

7.2 Interface connector

The figure below shows the physical pin location.

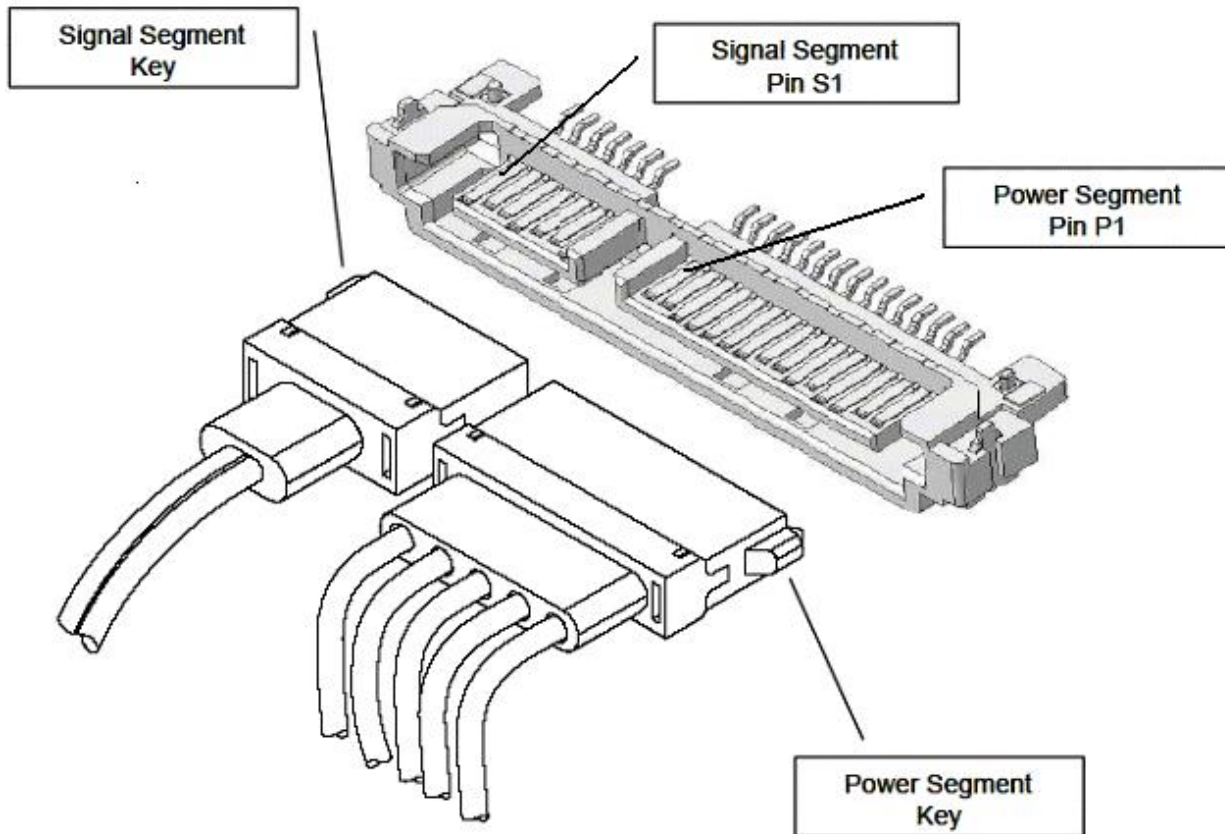

Figure 3 Interface connector pin assignments

- All pins are in a single row, with a 1.27 mm (050") pitch.
- The comments on the mating sequence in Table in the section 7.3 apply to the case of back-plane blind-mate connector only. In this case, the mating sequences are:(1)the ground pins P4 and P12;(2) the pre-charge power pins and the other ground pins; and (3) the signal pins and the rest of the power pins.
- There are three power pins for each voltage. One pin from each voltage is used for pre-charge in the backplane blind-mate situation.
- If a device uses 3.3V, then all V33 pins must be terminated. Otherwise, it is optional to terminate any of the V33 pins
- If a device uses 5.0V, then all V5 pins must be terminated. Otherwise, it is optional to terminate any of the V5 pins
- If a device uses 12.0V, then all V12 pins must be terminated. Otherwise, it is optional to terminate any of the V12 pins.

7.3 Signal definitions

The pin assignments of interface signals are listed as follows:

	No.	Plug Connector pin definition		Signal	I/O
Signal	S1	GND	2nd mate	Gnd	
	S2	A+	Differential signal A from Phy	RX+	Input
	S3	A-		RX-	Input
	S4	Gnd	2nd mate	Gnd	
	S5	B-	Differential signal B from Phy	TX-	Output
	S6	B+		TX+	Output
	S7	Gnd	2nd mate	Gnd	
Key and spacing separate signal and power segments					
Power	P1	V33	3.3V power	3.3V	
	P2	V33	3.3V power	3.3V	
	P3	V33	3.3V power, pre-charge, 2nd Mate	3.3V	
	P4	Gnd	1st mate	Gnd	
	P5	Gnd	2nd mate	Gnd	
	P6	Gnd	2nd mate	Gnd	
	P7	V5	5V power,pre-charge,2nd Mate	5V	
	P8	V5	5V power	5V	
	P9	V5	5V power	5V	
	P10	Gnd	2nd mate	Gnd	
	P11	DAS/DSS	Device Activity Signal / Disable Staggered Spinup1	Note 1	
	P12	Gnd	1st mate	Gnd	
	P13	V12	12V power,pre-charge,2nd mate	V12	
	P14	V12	12V power	V12	
	P15	V12	12V power	V12	

Table 23 Interface connector pins and I/O signals

Note 1;

Pin P11 is used by the hard disk drive to provide the host with an activity indication and by the host to indicate whether staggered spin-up should be used.

The signal the hard disk drive provides for activity indication is a low-voltage low-current driver.

If pin P11 is asserted low, the drive shall disable staggered spin-up and immediately initiate spin-up. If pin P11 is not connected in the host system (floating), the hard disk drive shall enable staggered spin-up.

7.3.1 TX+ / TX-

These signal are the outbound high-speed differential signals that are connected to the serial ATA cable

7.3.2 RX+ / RX-

These signals are the inbound high-speed differential signals that are connected to the serial ATA cable.

The following standard shall be referenced about signal specifications.

Serial ATA: High Speed Serialized AT Attachment Revision 1.0a 7-January -2003

7.3.3 Out of band signaling

Figure 4 shows the timing of COMRESET, COMINIT and COMWAKE.

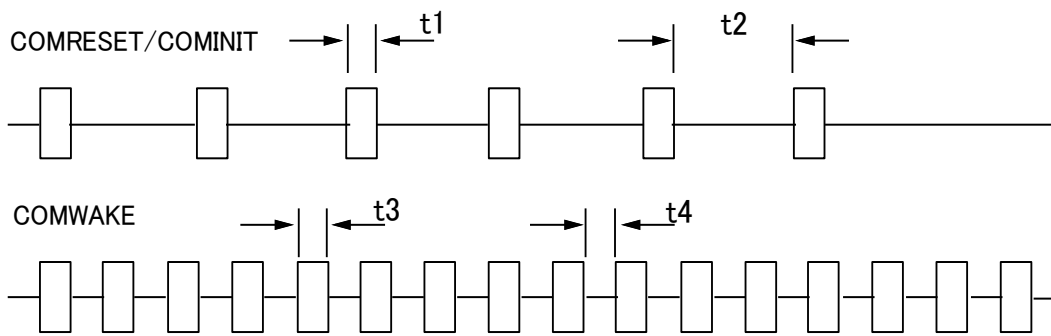

	PARAMETER DESCRIPTION	Nominal (ns)
T1	ALIGN primitives	106.7
T2	Spacing	320
T3	ALIGN primitives	106.7
T4	Spacing	106.7

Figure 4 Parameter descriptions

Part 2 Interface Specification

8 General

8.1 Introduction

This specification describes the host interface of HTE5450XXA7E680.

The interface conforms to following Working Document of Information technology with certain limitations described in the chapter 9 “Deviations from Standard”

Serial ATA International Organization : Serial ATA Revision 2.6 dated on 15 February 2007

AT Attachment 8 – ATA/ATAPI Command Set (ATA8-ACS) Revision 3f dated on 11 December 2006

HTE5450XXA7E680 supports following vendor-specific functions.

- Format Unit Function
- SENSE CONDITION command

8.2 Terminology

Device	Device indicates HTE5450XXA7E680
Host	Host indicates the system that the device is attached to.
INTRQ	Interrupt request (Device or Host)

9 Deviations from Standard

The device conforms to the referenced specifications, with deviations described below.

The interface conforms to the Working Document of Information Technology, AT Attachment 8 – ATA/ATAPI Command Set (ATA/ATAPI8-ACS) with deviation as follows:

S.M.A.R.T. Return Status S.M.A.R.T. RETURN STATUS subcommand does not check advisory attributes. That is, the device will not report threshold exceeded condition unless pre-failure attributes exceed their corresponding thresholds. For example, Power-On Hours Attribute never results in negative reliability status.

Check Power Mode Check Power Mode command returns FFh to Sector Count Register when the device is in Idle mode. This command does not support 80h as the return value.

10 Physical Interface

Physical Interface is described in Functional Specification part.

11 Registers

In Serial ATA, the host adapter contains a set of registers that shadow the contents of the traditional device registers, referred to as the Shadow Register Block. Shadow Register Block registers are interface registers used for delivering commands to the device or posting status from the device. About details, please refer to the Serial ATA Specification.

In the following cases, the host adapter sets the BSY bit in its shadow Status Register and transmits a FIS to the device containing the new contents.

- Command register is written in the Shadow Register Block
- Device Control register is written in the Shadow Register Block with a change of state of the SRST bit
- COMRESET is requested

11.1 Register naming convention

This specification uses the same naming conventions for the Command Block Registers as the ATA8-ACS standard. However, the register naming convention is different from that uses in the Serial ATA 2.6 specification. The following table defines the corresponding of the register names used in this specification with those used in the Serial ATA 2.6 specification.

Serial ATA register name	Register name in this specification when writing registers	Register name in this specification when reading registers
Features	Feature current	
Features (exp)	Feature previous	
Sector count	Sector count current	Sector count HOB=0
Sector count (exp)	Sector count previous	Sector count HOB=1
LBA low	LBA low current	LBA low HOB=0
LBA low (exp)	LBA low previous	LBA low HOB=1
LBA mid	LBA mid current	LBA mid HOB=0
LBA mid (exp)	LBA mid previous	LBA mid HOB=1
LBA high	LBA high current	LBA mid HOB=0
LBA high (exp)	LBA high previous	LBA mid HOB=1
Device	Device	Device
Command	Command	N/A
Control	Device Control	N/A
Status	N/A	Status
Error	N/A	Error

Table 24 Register naming convention and correspondence

11.2 Command register

This register contains the command code being sent to the device. Command execution begins immediately after this register is written. The command set is shown in “Table 42 Command set” on page 73.

All other registers required for the command must be set up before writing the Command Register.

11.3 Device Control Register

Device Control Register							
7	6	5	4	3	2	1	0
-	-	-	-	1	SRST	-IEN	0

Table 25 Device Control Register

Bit Definitions

SRST (RST)

Software Reset. The device is held reset when RST=1. Setting RST=0 reenables the device.

The host must set RST=1 and wait for at least 5 microseconds before setting RST=0, to ensure that the device recognizes the reset.

-IEN

Interrupt Enable. When IEN=0, and the device is selected, device interrupts to the host will be enabled. When IEN=1, or the device is not selected, device interrupts to the host will be disabled.

11.4 Device Register

Device Register							
7	6	5	4	3	2	1	0
-	L	-	0	HS3	HS2	HS1	HS0

Table 26 Device Register

This register contains the device and head numbers.

Bit Definitions

L

Binary encoded address mode select. When L=0, addressing is by CHS mode. When L=1, addressing is by LBA mode.

HS3,HS2,HS1,HS0

The HS3 through HS0 contain bits 24-27 of the LBA. At command completion, these bits are updated to reflect the current LBA bits 24-27.

11.5 Error Register

Error Register							
7	6	5	4	3	2	1	0
CRC	UNC	0	IDNF	0	ABRT	TK0NF	AMNF

Table 27 Error Register

This register contains status from the last command executed by the device, or a diagnostic code.

At the completion of any command except Execute Device Diagnostic, the contents of this register are valid always even if ERR=0 in the Status Register.

Following a power on, a reset, or completion of an Execute Device Diagnostic command, this register contains a diagnostic code. See “Table 31 Diagnostic Codes” on Page46 for the definition.

Bit Definitions

ICRCE (CRC)	Interface CRC Error. CRC=1 indicates a CRC error has occurred on the data bus during a Ultra-DMA transfer.
UNC	Uncorrectable Data Error. UNC=1 indicates an uncorrectable data error has been encountered.
IDNF (IDN)	ID Not Found. IDN=1 indicates the requested sector’s ID field could not be found.
ABRT (ABT)	Aborted Command. ABT=1 indicates the requested command has been aborted due to a device status error or an invalid parameter in an output register.
TK0NF (T0N)	Track 0 Not Found. T0N=1 indicates track 0 was not found during a Recalibrate command.
AMNF (AMN)	Address Mark Not Found. AMN=1 indicates the data address mark has not been found after finding the correct ID field for the requested sector. This bit is obsolete.

11.6 Features Register

This register is command specific. This is used with the Set Features command, S.M.A.R.T. Function Set command and Format Unit command.

11.7 LBA High Register

This register contains Bits 16-23. At the end of the command, this register is updated to reflect the current LBA Bits 16-23.

When 48-bit addressing commands are used, the “most recently written” content contains LBA Bits 16-23, and the “previous content” contains Bits 40-47. The 48-bit Address feature set is described in “12.12 48-bit Address Feature Set”.

11.8 LBA Low Register

This register contains Bits 0-7. At the end of the command, this register is updated to reflect the current LBA Bits 0-7.

When 48-bit commands are used, the “most recently written” content contains LBA Bits 0-7, and the “previous content” contains Bits 24-31.

11.9 LBA Mid Register

This register contains Bits 8-15. At the end of the command, this register is updated to reflect the current LBA Bits 8-15.

When 48-bit addressing commands are used, the “most recently written” content contains LBA Bits 8-15, and the “previous content” contains Bits 32-39.

11.10 Sector Count Register

This register contains the number of sectors of data requested to be transferred on a read or write operation between the host and the device. If the value in the register is set to 0, a count of 256 sectors (in 28-bit addressing) or 65,536 sectors (in 48-bit addressing) is specified.

If the register is zero at command completion, the command was successful. If not successfully completed, the register contains the number of sectors which need to be transferred in order to complete the request.

The contents of the register are defined otherwise on some commands. These definitions are given in the command descriptions.

11.11 Status Register

Status Register							
7	6	5	4	3	2	1	0
BSY	DRDY	DF	DSC	DRQ	CORR	IDX	ERR

Table 28 Status Register

This register contains the device status. The contents of this register are updated whenever an error occurs and at the completion of each command.

If the host reads this register when an interrupt is pending, it is considered to be the interrupt acknowledge. Any pending interrupt is cleared whenever this register is read.

If BSY=1, no other bits in the register are valid.

Bit Definitions

BSY	Busy. BSY=1 whenever the device is accessing the registers. The host should not read or write any registers when BSY=1. If the host reads any register when BSY=1, the contents of the Status Register will be returned.
DRDY (RDY)	Device Ready. RDY=1 indicates that the device is capable of responding to a command. RDY will be set to 0 during power on until the device is ready to accept a command.
DF	Device Fault. DF=1 indicates that the device has detected a write fault condition. DF is set to 0 after the Status Register is read by the host.
DSC	Device Seek Complete. DSC=1 indicates that a seek has completed and the device head is settled over a track. DSC is set to 0 by the device just before a seek begins. When an error occurs, this bit is not changed until the Status Register is read by the host, at which time the bit again indicates the current seek complete status. When the device enters into or is in Standby mode or Sleep mode, this bit is set by device in spite of not spinning up.
DRQ	Data Request. DRQ=1 indicates that the device is ready to transfer a word or byte of data between the host and the device. The host should not write the Command register when DRQ=1.
CORR (COR)	Corrected Data. Always 0.
IDX	Index. Always 0
ERR	ERR=1 indicates that an error occurred during execution of the previous command. The Error Register should be read to determine the error type. The device sets ERR=0 when the next command is received from the host.

12 General Operation Descriptions

12.1 Reset Response

There are three types of reset in ATA as follows:

- Power On Reset (POR)** The device executes a series of electrical circuitry diagnostics, spins up the HDA, tests speed and other mechanical parametric, and sets default values.
- COMRESET** COMRESET is issued in Serial ATA bus.
The device resets the interface circuitry as well as Soft Reset.
- Soft Reset (Software Reset)** SRST bit in the Device Control Register is set, then is reset.
The device resets the interface circuitry according to the Set Features requirement.

The actions of each reset are shown in “Table 29 Reset Response Table” on Page45

	POR	COMRESET	Soft Reset
Aborting Host interface	-	o	o
Aborting Device operation	-	(*1)	(*1)
Initialization of hardware	O	x	x
Internal diagnostic	O	x	x
Starting spindle motor	(*4)	x	x
Initialization of registers (*2)	O	o	o
Reverting programmed parameters to default	O	(*5)	
Power mode	(*4)	(*3)	(*3)
Reset Standby timer value	o	o	x

O ---- execute
X ---- not execute

Note.

(*1) Execute after the data in write cache has been written.

(*2) Default value on POR is shown in “Table 30 Default Register Values” on Page46.

(*3) In the case of sleep mode, the device goes to standby mode. In other case, the device does not change current mode.

(*4) According to the initial power mode selection.

(*5) See 12.13 Software Setting Preservation Feature Set.

Table 29 Reset Response Table

12.1.1 Register Initialization

After power on, COMRESET, or software reset, the register values are initialized as shown in the following table.

Register	Default Value
Error	Diagnostic Code
Sector Count	01h
LBA Low	01h
LBA Mid	00h
LBA High	00h
Device	00h
Status	50h
Alternate Status	50h

Table 30 Default Register Values

The meaning of the Error Register diagnostic codes resulting from power on, COMRESET or the Execute Device Diagnostic command are shown in the following table.

Code	Description
01h	No error Detected
02h	Formatter device error
03h	Sector buffer error
04h	Ecc circuitry error
05h	Controller microprocessor error

Table 31 Diagnostic Codes

12.2 Diagnostic and Reset considerations

The Set Max password, the Set Max security mode and the Set Max unlock counter don't retain over a Power On Reset but persist over a COMRESET or Soft Reset.

For each Reset and Execute Device Diagnostic, the Diagnostic is done as follows:

Execute Device Diagnostic

In all the above cases: Power on, COMRESET, Soft reset, and the EXECUTE DEVICE DIAGNOSTIC command the Error register is shown in the following table.

Device 0 Passed	Error Register
Yes	01h
No	0xh

Where x indicates the appropriate Diagnostic Code for the Power on, COMRESET, Soft reset, or Device Diagnostic error.

Table 32 Reset error register values

12.3 Power-off considerations

12.3.1 Load/Unload

Load/Unload is a functional mechanism of the HDD. It is controlled by the drive microcode. Specifically, unloading of the heads is invoked by the commands:

Command	Response
Standby	UL -> Comp.
Standby immediate	UL -> Comp.
Sleep	UL -> Comp.

“UL” means “unload”.

“Comp” means “complete”.

Table 33 Device’s behavior by ATA commands

Load/unload is also invoked as one of the idle modes of the drive.

The specified start/stop life of the product assumes that load/unload is operated normally, NOT in emergency mode.

12.3.2 Emergency unload

When HDD power is interrupted while the heads are still loaded, the microcode cannot operate and the normal 5V power is unavailable to unload the heads. In this case, normal unload is not possible, so the heads are unloaded by routing the back-EMF of the spinning motor to the voice coil. The actuator velocity is greater than the normal case, and the unload process is inherently less controllable without a normal seek current profile.

Emergency unload is intended to be invoked in rare situations. Because this operation is inherently uncontrolled, it is more mechanically stressful than a normal unload.

A single emergency unload operation is more stressful than 100 normal unloads. Use of emergency unload reduces the start/stop life of the HDD at a rate at least 100X faster than that of normal unload, and may damage the HDD.

12.3.3 Required power-off sequence

Problems can occur on most HDDs when power is removed at an arbitrary time. Examples:

- Data loss from the write buffer.
- If the drive is writing a sector, the sector contents are destroyed and reading that sector results in a hard error.

You may then turn off the HDD in the following order:

1. Issue Standby, Standby Immediate or sleep command.
2. Wait until COMMAND COMPLETE STATUS is returned.
3. Terminate power to HDD.

This power-down sequence should be followed for entry into any system power-down state, or system suspend state, or system hibernation state. In a robustly designed system, emergency unload is limited to rare scenarios such as battery removal during operation.

12.4 Sector Addressing Mode

All addressing of data sectors recorded on the device's media is by a logical sector address. The logical CHS address for HTE5450XXA7E680 is different from the actual physical CHS location of the data sector on the disk media.

HTE5450XXA7E680 support both Logical CHS Addressing Mode and LBA Addressing Mode as the sector addressing mode.

The host system may select either the currently selected CHS translation addressing or LBA addressing on a command-by-command basis by using the L bit in the DEVICE register. So a host system must set the L bit to 1 if the host uses LBA Addressing mode.

12.4.1 Logical CHS Addressing Mode

The logical CHS addressing is made up of three fields: the cylinder number, the head number and the sector number. Sectors are numbered from 1 to the maximum value allowed by the current CHS translation mode but can not exceed 255(0FFh). Heads are numbered from 0 to the maximum value allowed by the current CHS translation mode but can not exceed 15(0Fh). Cylinders are numbered from 0 to the maximum value allowed by the current CHS translation mode but cannot exceed 65535(0FFFFh).

When the host selects a CHS translation mode using the INITIALIZE DEVICE PARAMETERS command, the host requests the number of sectors per logical track and the number of heads per logical cylinder. The device then computes the number of logical cylinders available in requested mode.

The default CHS translation mode is described in the Identify Device Information. The current CHS translation mode also is described in the Identify Device Information.

12.4.2 LBA Addressing Mode

Logical sectors on the device shall be linearly mapped with the first LBA addressed sector (sector 0) being the same sector as the first logical CHS addressed sector (cylinder 0, head 0, sector 1). Irrespective of the logical CHS translation mode currently in effect, the LBA address of a given logical sector does not change. The following is always true:

$$\text{LBA} = (\text{cylinder} * \text{heads_per_cylinder} + \text{heads}) * \text{sectors_per_track} + \text{sector} - 1$$

where heads_per_cylinder and sectors_per_track are the current translation mode values.

On LBA addressing mode, the LBA value is set to the following register.

Device	<---	LBA bits 27-24
LBA High	<---	LBA bits 23-16
LBA Mid	<---	LBA bits 15- 8
LBA Low	<---	LBA bits 7- 0

12.5 Power Management Feature

The power management feature set permits a host to modify the behavior in a manner which reduces the power required to operate. The power management feature set provides a set of commands and a timer that enables a device to implement low power consumption modes.

HTE5450XXA7E680 implements the following set of functions.

1. A Standby timer
2. Idle command
3. Idle Immediate command
4. Sleep command
5. Standby command
6. Standby Immediate command

12.5.1 Power Mode

Sleep Mode	The lowest power consumption when the device is powered on occurs in Sleep Mode. When in sleep mode, the device requires a reset to be activated.
Standby Mode	The device interface is capable of accepting commands, but as the media may not immediately accessible, there is a delay while waiting for the spindle to reach operating speed.
Idle Mode	Refer to the section of Adaptive Battery Life Extender Feature.
Active Mode	The device is in execution of a command or accessing the disk media with read look-ahead function or write cache function.

12.5.2 Power Management Commands

The Check Power Mode command allows a host to determine if a device is currently in, going to or leaving standby mode.

The Idle and Idle Immediate commands move a device to idle mode immediately from the active or standby modes. The idle command also sets the standby timer count and starts the standby timer.

The sleep command moves a device to sleep mode. The device's interface becomes inactive at the completion of the sleep command. A reset is required to move a device out of sleep mode. When a device exits sleep mode it will enter standby mode.

The Standby and Standby Immediate commands move a device to standby mode immediately from the active or idle modes. The standby command also sets the standby timer count.

12.5.3 Standby/Sleep command completion timing

1. Confirm the completion of writing cached data in the buffer to media
2. Unload heads on the ramp
3. Set DRDY bit and DSC bit in Status Register
4. Activate the spindle break to stop the spindle motor
5. Wait until spindle motor is stopped
6. Perform post process

12.5.4 Status

In the active, idle and standby modes, the device shall have RDY bit of the status register set. If BSY bit is not set, device shall be ready to accept any command.

In sleep mode, the device's interface is not active. A host shall not attempt to read the device's status or issue commands to the device.

12.5.5 Interface Capability for Power Modes

Each power mode affects the physical interface as defined in the following table:

Mode		BSY	RDY	Interface active	Media
Active		x	x	Yes	Active
Idle		0	1	Yes	Active
Standby		0	1	Yes	Inactive
Sleep		x	x	No	Inactive

Table 34 Power conditions

Ready(RDY) is not a power condition. A device may post ready at the interface even though the media may not be accessible.

12.5.6 Initial Power Mode at Power On

After power on the device goes to IDLE mode or STANDBY mode depending on the setting of the Power Up in Standby Feature set

12.6 Interface Power Management Mode(Slumber and Partial)

Interface Power Management Mode is supported by both Device-initiated interface power management and Host-initiated interface power management. Please refer to the Serial ATA Specification about Power Management Mode.

12.7 S.M.A.R.T. Function

The intent of Self-monitoring, analysis and reporting technology (S.M.A.R.T) is to protect user data and prevent unscheduled system downtime that may be caused by predictable degradation and/or fault of the device. By monitoring and storing critical performance and calibration parameters, S.M.A.R.T devices employ sophisticated data analysis algorithms to predict the likelihood of near-term degradation or fault condition. By alerting the host system of a negative reliability status condition, the host system can warn the user of the impending risk of a data loss and advise the user of appropriate action.

Since S.M.A.R.T. utilizes the internal device microprocessor and other device resources, there may be some small overhead associated with its operation. However, special care has been taken in the design of the S.M.A.R.T. algorithms to minimize the impact to host system performance. Actual impact of S.M.A.R.T. overhead is dependent on the specific device design and the usage patterns of the host system. To further ensure minimal impact to the user, S.M.A.R.T. capable devices are shipped from the device manufacturer's factory with the S.M.A.R.T. feature disabled. S.M.A.R.T. capable devices can be enabled by the system OEMs at time of system integration or in the field by aftermarket products.

12.7.1 Attributes

Attributes are the specific performance or calibration parameters that are used in analyzing the status of the device. Attributes are selected by the device manufacturer based on that attribute's ability to contribute to the prediction of degrading or faulty conditions for that particular device. The specific set of attributes being used and the identity of these attributes is vendor specific and proprietary.

12.7.2 Attribute values

Attribute values are used to represent the relative reliability of individual performance or calibration attributes. Higher attribute values indicate that the analysis algorithms being used by the device are predicting a lower probability of a degrading or fault condition existing. Accordingly, lower attribute values indicate that the analysis algorithms being used by the device are predicting a higher probability of a degrading or fault condition existing. There is no implied linear reliability relationship corresponding to the numerical relationship between different attribute values for any particular attribute.

12.7.3 Attribute thresholds

Each attribute value has a corresponding attribute threshold limit which is used for direct comparison to the attribute value to indicate the existence of a degrading or faulty condition. The numerical value of the attribute thresholds are determined by the device manufacturer through design and reliability testing and analysis. Each attribute threshold represents the lowest limit to which its corresponding attribute value can be equal while still retaining a positive reliability status. Attribute thresholds are set at the device manufacturer's factory and cannot be changed in the field. The valid range for attribute thresholds is from 1 through 253 decimal.

12.7.4 Threshold exceeded condition

If one or more attribute values are less than or equal to their corresponding attribute thresholds, then the device reliability status is negative, indicating an impending degrading or faulty condition.

12.7.5 S.M.A.R.T. commands

The S.M.A.R.T. commands provide access to attribute values, attribute thresholds and other logging and reporting information.

12.7.6 S.M.A.R.T operation with power management modes

The device saves attribute values automatically on every head unload timing except the emergency unload, even if the attribute auto save feature is not enabled. The head unload is done not only by Standby, Standby Immediate, or Sleep command, but also by the automatic power saving functions like ABLE-3 or Standby timer. So basically it is not necessary for a host system to enable the attribute auto save feature, when it utilizes the power management. If the attribute auto save feature is enabled, attribute values will be saved after 30minutes passed since the last saving, besides above condition.

12.8 Security Mode Feature Set

Security Mode Feature Set is a powerful security feature. With a device lock password, a user can prevent unauthorized access to hard disk device even if the device is removed from the computer.

New commands are supported for this feature as below.

Security Set Password	('F1'h)
Security Unlock	('F2'h)
Security Erase Prepare	('F3'h)
Security Erase Unit	('F4'h)
Security Freeze Lock	('F5'h)
Security Disable Password	('F6'h)

12.8.1 Security mode

Following security modes are provided.

Device Locked mode	The device disables media access commands after power on. Media access commands are enabled by either a security unlock command or a security erase unit command.
Device Unlocked mode	The device enables all commands. If a password is not set this mode is entered after power on, otherwise it is entered by a security unlock or a security erase unit command.
Device Frozen mode	The device enables all commands except those which can update the device lock function, set/change password. The device enters this mode via a Security Freeze Lock command. It cannot quit this mode until power off.

12.8.2 Security Level

Following security levels are provided.

High level security	When the device lock function is enabled and the User Password is forgotten the device can be unlocked via a Master Password.
Maximum level security	When the device lock function is enabled and the User Password is forgotten then only the Master Password with a Security Erase Unit command can unlock the device. Then user data is erased.

12.8.3 Password

This function can have 2 types of passwords as described below.

Master Password	When the Master Password is set, the device does NOT enable the Device Lock Function, and the device can NOT be locked with the Master Password, but the Master Password can be used for unlocking the device locked.
User Password	The User Password should be given or changed by a system user. When the User Password is set, the device enables the Device Lock Function, and then the device is locked on next power on reset. If Software Setting Preservation is disabled, the device is locked on COMRESET as well.

The system manufacturer/dealer who intends to enable the device lock function for the end users, must set the master password even if only single level password protection is required. Otherwise, if the User Password is forgotten then no one can unlock the device which is locked with the User Password.

12.8.4 Master Password Revision Code

This Master Password Revision Code is set by Security Set Password command with the master password. And this revision code field is returned in the Identify Device command word 92. The valid revision codes are 0001h to FFFEh. The default value of Master Password Revision Code is FFFEh.

Value 0000h and FFFFh is reserved.

12.8.5 Operation example

12.8.5.1 Master Password setting

The system manufacturer/dealer can set a initial Master Password using the Security Set Password command, without enabling the Device Lock Function.

12.8.5.2 User Password setting

When a User Password is set, the device will automatically enter lock mode the next time the device is powered on.

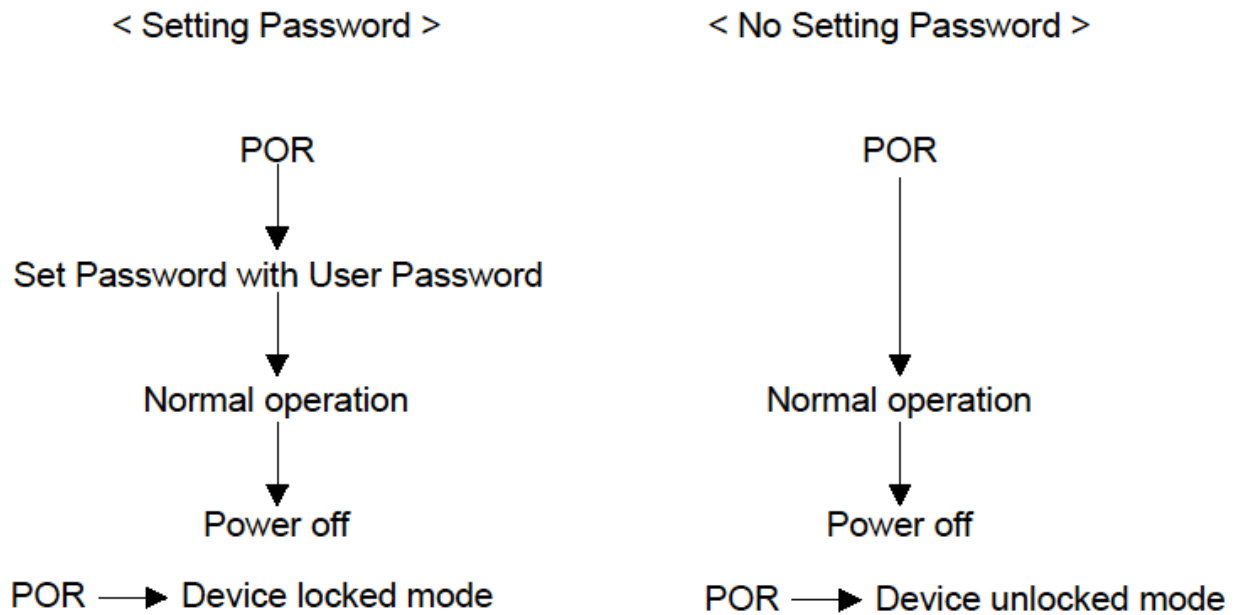
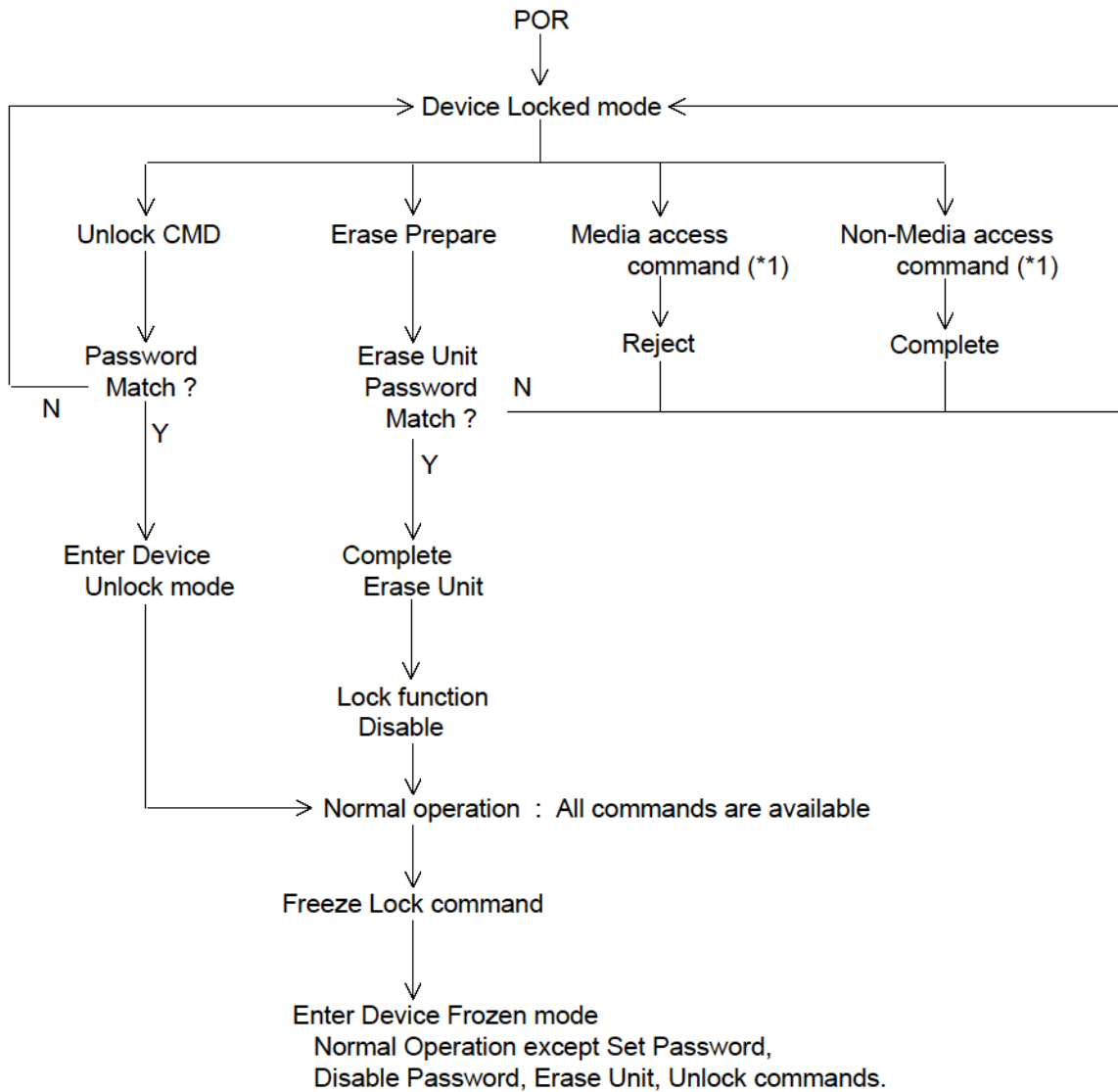

Figure 5 Initial Setting

12.8.5.3 Operation from POR after User Password is set

When Device Lock Function is enabled, the device rejects media access command until a Security Unlock command is successfully completed.



(*1) refer to Table 35 Command table for device lock operation on Page 57 and Table 36 Command table for device lock operation - continued on Page 58.

Figure 6 Usual Operation

12.8.5.4 User Password Lost

If the User Password is forgotten and High level security is set, the system user can't access any data. However the device can be unlocked using the Master Password.

If a system user forgets the User Password and Maximum security level is set, data access is impossible. However the device can be unlocked using the Security Erase Unit command to unlock the device and erase all user data with the Master Password.

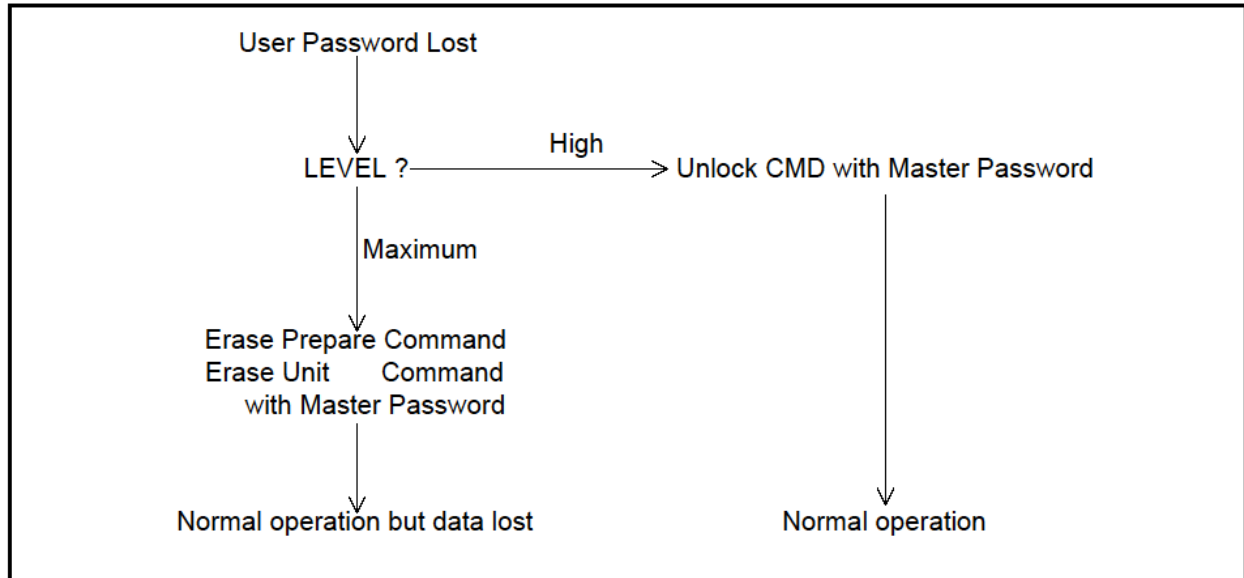

Figure 7 Password Lost

12.8.5.5 Attempt limit for SECURITY UNLOCK command

The SECURITY UNLOCK command has an attempt limit. The purpose of this attempt limit is to prevent that someone attempts to unlock the drive by using various passwords many times.

The device counts the password mismatch. If the password does not match, the device counts it up without distinguishing the Master password and the User password. If the count reaches 5, EXPIRE bit(bit 4) of Word 128 in Identify Device information is set, and then SECURITY ERASE UNIT command and SECURITY UNLOCK command are aborted until a power off. The count and EXPIRE bit are cleared after a power on reset.

12.8.6 Command Table

This table shows the device's response to commands when the Security Mode Feature Set (Device lock function) is enabled.

Command	Device Locked Mode	Device Unlock Mode	Device Frozen Mode
Check Power Mode	o	o	o
Device Configuration RESTORE	x	o	o
Device Configuration FREEZE LOCK	x	o	o
Device Configuration IDENTIFY	x	o	o
Device Configuration SET	x	o	o
Download Microcode	x	o	o
Execute Device Diagnostic	o	o	o
Flush Cache	x	o	o
Flush Cache Ext	x	o	o
Format Track	x	o	o
Format Unit	x	o	o
Identify Device	o	o	o
Idle	o	o	o
Idle Immediate	o	o	o
Idle Immediate with Unload option	o	o	o
Initialize Device Parameters	o	o	o
Read Buffer	o	o	o
Read DMA	x	o	o
Read DMA Ext	x	o	o
Read FPDMA Queued	x	o	o
Read Log Ext	o	o	o
Read Log DMA Ext	o	o	o
Read Multiple	x	o	o
Read Multiple Ext	x	o	o
Read Native Max Address	o	o	o
Read Native Max Address Ext	o	o	o
Read Sector(s)	x	o	o
Read Sector(s) Ext	x	o	o
Read Verify Sector(s)	x	o	o
Read Verify Sector(s) Ext	x	o	o
Recalibrate	o	o	o
Security Disable Password	x	o	x
Security Erase Prepare	o	o	x
Security Erase Unit	o	o	x
Security Freeze Lock	x	o	o
Security Set Password	x	o	x
Security Unlock	o	o	x
Seek	o	o	o
Sense Condition	o	o	o
Set Features	o	o	o

Table 35 Command table for device lock operation

Command	Device Locked Mode	Device Unlock Mode	Device Frozen Mode
Set Max Address	x	o	o
Set Max Address Ext	x	o	o
Set Max Freeze Lock	x	o	o
Set Max Lock	x	o	o
Set Max Set Password	x	o	o
Set Max Unlock	x	o	o
Set Multiple Mode	o	o	o
Sleep	o	o	o
S.M.A.R.T. Disable Operations	o	o	o
S.M.A.R.T. Enable/Disable Automatic Offline	o	o	o
S.M.A.R.T. Enable/Disable Attribute Autosave	o	o	o
S.M.A.R.T. Enable Operations	o	o	o
S.M.A.R.T. Execute Off-line Immediate	o	o	o
S.M.A.R.T. Read Attribute Values	o	o	o
S.M.A.R.T. Read Attribute Thresholds	o	o	o
S.M.A.R.T. Read Log Sector	o	o	o
S.M.A.R.T. Write Log Sector	o	o	o
S.M.A.R.T. Return Status	o	o	o
S.M.A.R.T. Save Attribute Values	o	o	o
Standby	o	o	o
Standby Immediate	o	o	o
Write Buffer	o	o	o
Write DMA	x	o	o
Write DMA Ext	x	o	o
Write DMA FUA Ext	x	o	o
Write FPDMA Queued	x	o	o
Write Log Ext	x	o	o
Write Log DMA Ext	x	o	o
Write Multiple	x	o	o
Write Multiple Ext	x	o	o
Write Multiple FUA Ext	x	o	o
Write Sector(s)	x	o	o
Write Sector(s) Ext	x	o	o
Write Uncorrectable Ext	x	o	o

Table 36 Command table for device lock operation - continued

12.9 Protected Area Function

Protected Area Function is to provide the 'protected area' which can not be accessed via conventional method. This 'protected area' is used to contain critical system data such as BIOS or system management information. The contents of entire system main memory may also be dumped into 'protected area' to resume after system power off.

The LBA/CYL changed by following command affects the Identify Device Information.

Two commands are defined for this function.

Read Native Max Address ('F8'h)
Set Max Address ('F9'h)

Four security extension commands are implemented as sub-functions of the Set Max Address.

Set Max Set Password
Set Max Lock
Set Max Freeze Lock
Set Max Unlock

12.9.1 Example for operation (In LBA mode)

Assumptions :

For better understanding, the following example uses actual values for LBA, size, etc. Since it is just an example, these values could be different.

Device characteristics

Capacity (native)	:	536,870,912 byte (536MB)
Max LBA (native)	:	1,048,575 (0FFFFFFh)
Required size for protected area	:	8,388,608 byte
Required blocks for protected area	:	16,384 (004000h)
Customer usable device size	:	528,482,304 byte (528MB)
Customer usable sector count	:	1,032,192 (0FC000h)
LBA range for protected area	:	0FC000h to 0FFFFFFh

Shipping HDDs from HDD manufacturer

When the HDDs are shipped from HDD manufacturer, the device has been tested to have a capacity of 536MB, flagging the media defects not to be visible by system.

1. Preparing HDDs at system manufacturer
 Special utility software is required to define the size of protected area and store the data into it.

The sequence is :

Issue Read Native Max Address command to get the real device max of LBA/CYL. Returned value shows that native device Max LBA is 0FFFFFFh regardless to the current setting.

Make entire device be accessible including the protected area by setting device Max LBA as 0FFFFFFh via Set Max Address command. The option could be either nonvolatile or volatile.

Test the sectors for protected area (LBA >= 0FC000h) if required.

Write information data such as BIOS code within the protected area.

Change maximum LBA using Set Max Address command to 0FBFFFh with nonvolatile option.

From this point, the protected area cannot be accessed until next Set Max Address command is issued. Any BIOSes, device drivers, or application software access the HDD as if that is the 528MB device because the device acts exactly same as real 528MB device does.

2. Conventional usage without system software support
 Since the HDD works as 528MB device, there is no special care to use this device for normal use.

3. Advanced usage using protected area

The data in the protected area is accessed by following.

Issue Read Native Max Address command to get the real device max LBA/CYL. Returned value shows that native device Max LBA is 0FFFFFFh regardless of the current setting.

Make entire device be accessible including the protected area by setting device Max LBA as 0FFFFFFh via Set Max Address command with volatile option. By using this option, unexpected power removal or reset will not make the protected area remained accessible.

Read information data from protected area.

Issue POR to inhibit any access to the protected area.

12.9.2 Set Max security extension commands

The Set Max Set Password command allows the host to define the password to be used during the current power on cycle. This password is not related to the password used for the Security Mode Feature set. When the password is set the device is in the Set Max Unlocked mode.

This command requests a transfer of a single sector of data from the host. The table shown below defines the content of this sector of information. The password is retained by the device until the next power cycle. When the device accepts this command the device is in Set Max Unlocked mode.

Word	Content
0	Reserved
1-16	Password (32 bytes)
17-255	Reserved

Table 37 Set Max Set Password data content

The Set Max Lock command allows the host to disable the Set Max commands (except Set Max Unlock and Set Max Freeze Lock) until the next power cycle or the issuance and acceptance of the Set Max Unlock command. When this command is accepted the device is in the Set Max Locked mode.

The Set Max Unlock command changes the device from the Set Max Locked mode to the Set Max Unlocked mode.

This command requests a transfer of a single sector of data from the host. The Table shown above defines the content of this sector of information. The password supplied in the sector of data transferred is compared with the stored Set Max password. If the password compare fails, then the device returns command aborted and decrements the unlock counter. On the acceptance of the Set Max Lock command, this counter is set to a value of five and is decremented for each password mismatch when Set Max Unlock is issued and the device is locked. When this counter reaches zero, then the Set Max Unlock command returns command aborted until a power cycle.

The Set Max Freeze Lock command allows the host to disable the SET Max commands (including Set Max Unlock) until the next power cycle. When this command is accepted the device is in the Set Max Frozen mode.

The password, the Set Max security mode and the unlock counter don't persist over a power cycle but does persist over a COMRESET or software reset.

Note that If this command is immediately preceded by a Read Native Max Address command regardless of Feature register value, it shall be interpreted as a Set Max Address command.

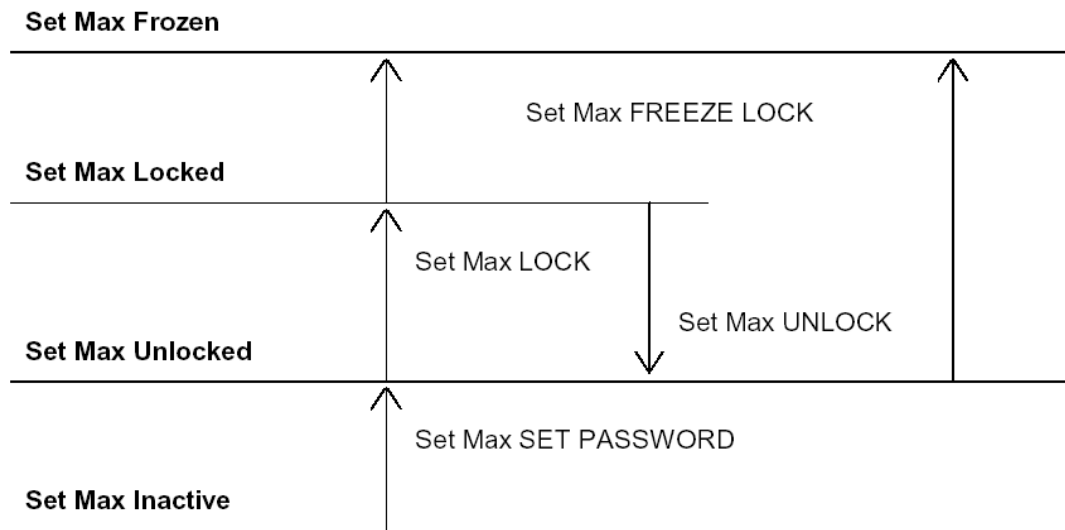

Figure 8 Set Max security mode transition

12.10 Write Cache Function

Write cache is a performance enhancement whereby the device reports completion of the write command (Write Sector(s) and Write Multiple) to the host as soon as the device has received all of the data into its buffer. The device assumes responsibility to write the data subsequently onto the disk.

- While writing data after completed acknowledgment of a write command, soft reset or COMRESET does not affect its operation. But power off terminates writing operation immediately and unwritten data are to be lost.
- Flush cache, Soft reset, Standby, Standby Immediate and Sleep are executed after the completion of writing to disk media on enabling write cache function. So the host system can confirm the completion of write cache operation by issuing flush cache command, Soft reset, Standby command, Standby Immediate command or Sleep command, and then, by confirming its completion.

12.11 Reassign Function

The reassign function is used with read commands and write commands. The sectors of data for reassignment are prepared as the spare data sector. The one entry can register up to 256 (512 byte/sector format) or 32 (4KB sector format) consecutive physical sectors maximally.

This reassignment information is registered internally, and the information is available right after completing the reassign function. Also the information is used on the next power on reset.

If the number of the spare sector reaches 0 sector, the reassign function will be disabled automatically.

The spare tracks for reassignment are located at regular intervals from Cylinder 0. As a result of reassignment, the physical location of logically sequenced sectors will be dispersed.

12.11.1 Auto Reassign Function

The sectors that show some errors may be reallocated automatically when specific conditions are met. The spare tracks for reallocation are located at regular intervals from Cylinder 0. The conditions for auto-reallocation are described below.

Non recovered write errors

When a write operation can not be completed after the Error Recovery Procedure(ERP) is fully carried out, the sector(s) are reallocated to the spare location. An error is reported to the host system only when the write cache is disabled and the auto reallocation fails.

If the number of available spare sectors reaches 16 sectors, the write cache function will be disabled automatically.

Non recovered read errors

When a read operation fails after defined ERP is fully carried out, a hard error is reported to the host system. This location is registered internally as a candidate for the reallocation. When a registered location is specified as a target of a write operation, a sequence of media verification is performed automatically. When the result of this verification meets the criteria, this sector is reallocated.

Recovered read errors

When a read operation for a sector failed once then recovered at the specific ERP step, this sector of data is reallocated automatically. A media verification sequence may be run prior to the relocation according to the pre-defined conditions.

12.12 48-bit Address Feature Set

The 48-bit Address feature set allows devices with capacities up to 281,474,976,710,655 sectors. This allows device capacity up to 144,115,188,075,855,360 bytes. In addition, the number of sectors that may be transferred by a single command are increased by increasing the allowable sector count to 16 bits.

Commands unique to the 48-bit Address feature set are:

- Flush Cache Ext
- Read DMA Ext
- Read Multiple Ext
- Read Native Max Address Ext
- Read Sector(s) Ext
- Read Verify Sector(s) Ext
- Set Max Address Ext
- Write DMA Ext
- Write Multiple Ext
- Write Sector(s) Ext

The 48-bit Address feature set operates in LBA addressing only. Devices also implement commands using 28-bit addressing, and 28-bit and 48-bit commands may be intermixed.

Support of the 48-bit Address feature set is indicated in the Identify Device response bit 10 word 83. In addition, the maximum user LBA address accessible by 48-bit addressable commands is contained in Identify Device response words 100 through 103.

When the 48-bit Address feature set is implemented, the native maximum address is the value returned by a Read Native Max Address Ext command. If the native maximum address is equal to or less than 268,435,455, a Read Native Max Address shall return the native maximum address. If the native maximum address is greater than 268,435,455, a Read Native Max Address shall return a value of 268,435,455.

12.13 Software Setting Preservation Feature Set

When a device is enumerated, software will configure the device using Set Features and other commands. These software settings are often preserved across software reset but not necessarily across hardware reset. In Parallel ATA, only commanded hardware resets can occur, thus legacy software only reprograms settings that are cleared for the particular type of reset it has issued. In Serial ATA, COMRESET is equivalent to hard reset and a non-commanded COMRESET may occur if there is an asynchronous loss of signal. Since COMRESET is equivalent to hardware reset, in the case of an asynchronous loss of signal some software settings may be lost without legacy software knowledge. In order to avoid losing important software settings without legacy driver knowledge, the software settings preservation ensures that the value of important software settings is maintained across a COMRESET. Software settings preservation may be enabled or disabled using Set Features with a subcommand code of 06h. Software settings preservation is enabled by default.

12.13.1 Preserved software settings

If Software setting preservation is enabled, the following settings are preserved across COMRESET. Otherwise settings are cleared across COMRESET.

Setting	Contents
Initialize device parameters	Track length
	Number of head
	Number of cylinder
	Capacity
Power Management Feature Set Standby Timer	Time to fall into standby mode
Security mode state	Security freeze lock
	Security unlock
Set max address	Capacity
Set feature	Write Cache Enable/Disable
	Set Transfer Mode
	Advanced Power Management Enable/Disable
	Read Look-Ahead
Set multiple mode	Block size

Table 38 Preserved Software Setting

12.14 Native Command Queuing

Native Command Queuing feature (Read / Write FPDMA Queued commands) is supported. Please refer to the Serial ATA II Specification about Native Command Queuing.

The host shall not issue a legacy ATA command while a native queued command is outstanding. Upon receiving a legacy ATA command while a native queued command is outstanding, the device aborts the command and halts command processing of outstanding native queued commands.

12.15 SMART Command Transport (SCT)

SMART Command Transport (SCT) feature set is supported. The SMART Read Log and SMART Write Log commands or Read Log Ext and Write Log Ext commands are used to issue a command in this feature sets. Log page E0h is used to issue commands and return status. Log page E1h is used to transport data. Please refer to the section 8 SCT Command Transport in ATA8-ACS specification for more detail.

Unique feature :

If the device has the PUIS(Power-up in Standby) feature set enabled and receive SCT Command /Status Request while the device is in the Standby power mode as a result a result of powering up in that mode, Device respond to the SCT Status Request without spinning up the media. SCT Status log has an available current HDD temperature.

The following Action codes are supported.

Action code	Description	
0002h	Write Same command	
0003h	Error Recovery Control command	
0004h	Feature Control command	
	Feature code 0001h	Write Cache
	Feature code 0003h	Time Interval for temperature logging
0005h	SCT Data Table command	

Table 39 SCT Action Code Supported

12.16 Power-Up In Standby (PUIS) feature set

The Power-Up In Standby (PUIS) feature set allows devices to be powered-up into the Standby power management state to minimize inrush current at power-up and to allow the host to sequence the spin-up of devices. This feature set may be enabled or disabled via the SET FEATURES command; Once this feature is enabled in a device, the device shall not disable the feature as a result of processing a power-on reset, a hardware reset, or a software reset.

If power-up into Standby is enabled, the device shall remain in Standby until receipt of the first command that requires the device to access the media, except the IDENTIFY DEVICE command.

The device implements this SET FEATURES subcommand, the fact that the feature is implemented is reported in the IDENTIFY DEVICE data. See Word 02 of “Table 57 Identify device information” on Page90 for the definition.

If the device:

- a) Implements the Enable/disable Power-up in Standby subcommand;
- b) Has the PUIS feature set enabled; and
- c) receives an IDENTIFY DEVICE while the device is in the Standby power mode as a result of powering up in that mode.

Then the device shall respond to the IDENTIFY DEVICE command without spinning up the media. If the device is unable to return a complete response without accessing the media, then the device shall set word 0 bit 2 to one to indicate that the response is incomplete. At a minimum, word 0 and word 2 shall be correctly reported. Those fields that are not provided shall be filled with zeros. Once a device is able to return all data for an IDENTIFY DEVICE command, the device shall return all data for those commands until after processing the next power-on reset.

Identify Device	Execute without spin-up
Set Features (Enable/Disable PUIS)	Execute without spin-up
Set Features (Spin-up)	Execute with spin-up
Reset	Execute without spin-up
Check Power Mode	Execute without spin-up
Diagnostics	Execute without spin-up
SMART	Execute with spin-up
Idle	Execute with spin-up
Idle with unload option (Unload Immediate)	Execute without spin-up
Standby / Standby Immediate / Sleep	Execute without spin-up
Security Unlock / Security Freeze Lock	Execute without spin-up
Any read/write commands	Execute with spin-up
Other commands	Execute with spin-up

Table 40 PM4: PUIS command behavior

12.17 Early Drive Ready (EDR) function

The Early Drive Ready (EDR) function is implemented. In this function, power on reset (POR) process is divided in two processes; POR1 and POR2. POR1 is the process for provide drive read operation; POR2 is the process for drive write operation. When EDR function is implemented, the drive returns Ready (Status: Error = 50:01) when POR1 is completed. POR2 is started by any of following condition.

- Write type commands received
- 2 seconds passed after drive ready
- 500 milliseconds command interval

POR2 is interrupted only by free fall sensor (FFS) or unload immediate (ULI) command interrupt. Other commands received while POR2 is running processed after POR2 is completed. After POR2 is interrupted by FFS or ULI, POR2 will be executed after FFS/ULI is resumed.

All ATA commands are divided in two groups; read type and write type. Two 'ready' states are defined for the EDR function supported drive; Read Ready and Full Ready. Drive enters 'Read Ready' state when POR1 is completed, and enters 'Full Ready' state when POR2 is completed. While 'Read Ready' state, drive accepts and executes read type commands. Write type commands are accepted but POR2 is carried out before executing the command.

Command Read / Write types are defined as follows. Soft reset and hard reset are treated as read type command.

Command	CMD Reg.	R/W	SubCommand	FTR Reg.	R/W Type
Check Power Mode	0x98	non	—	—	R
Check Power Mode	0xE5	non	—	—	R
Device Configuration Overlay	0xB1	non	—	—	R
Download Microcode	0x92	non	—	—	W
Execute Device Diagnostics	0x90	non	—	—	W
Flush cache	0xE7	non	—	—	W
Flush cache EXT	0xEA	non	—	—	W
Format Track	0x50	non	—	—	W
Format Unit	0xF7	non	—	—	W
Identify Device	0xEC	non	—	—	R
Idle	0x97	non	—	—	W
Idle	0xE3	non	—	—	W
Idle Immediate	0x95	non	—	—	W
Idle Immediate	0xE1	non	—	—	W
Initialize Device Parameters	0x91	non	—	—	R
Read Buffer	0xE4	non	—	—	R
Read DMA	0xC8	RW			R
Read DMA w/Retry	0xC9	RW			R
Read DMA EXT	0x25	RW			R
Read FPDMA Queued	0x60	RW			R
Read Log EXT	0x2F	non	—	—	R
Read Log EXT DMA	0x47	non	—	—	R
Read Multiple	0xC4	RW			R
Read Multiple EXT	0x29	RW			R
Read Native Max Address	0xF8	non	—	—	R
Read Native Max Address EXT	0x27	non	—	—	R
Read Sectors	0x20	RW			R
Read Sectors w/Retry	0x21	RW			R
Read Sectors EXT	0x24	RW			R
Read Verify Sectors	0x40	RW			R
Read Verify Sectors w/Retry	0x41	RW			R
Read Verify Sectors EXT	0x42	RW			R
Recalibrate	0x10	non	—	—	R
Security Disable Password	0xF6	non	—	—	R
Security Erase Prepare	0xF3	non	—	—	R
Security Erase Unit	0xF4	non	—	—	W
Security Freeze Lock	0xF5	non	—	—	R
Security Set Password	0xF1	non	—	—	R
Security Unlock	0xF2	non	—	—	R
Seek	0x70	non	—	—	R
Sense Condition	0xF0	non	—	—	R

Set Features	0xEF	non	↓	↓	↓
	0xEF	non	Enable Write cache	0x02	R
	0xEF	non	Set Transfer Mode	0x03	R
	0xEF	non	Enable Advanced Power management	0x05	R
	0xEF	non	Enable Power up in standby feature	0x06	R
	0xEF	non	Power up in standby spin-up	0x07	R
	0xEF	non	Enable use of Serial ATA Feature	0x10	R
	0xEF	non	Enable Free-fall control feature set	0x41	R
	0xEF	non	Disable read look ahead feature	0x55	R
	0xEF	non	Disable Write Cache	0x82	R
	0xEF	non	Disable Advanced Power management	0x85	R
	0xEF	non	Disable Power up in standby feature	0x86	R
	0xEF	non	Disale use of serial ATA feature	0x90	R
	0xEF	non	Enable look ahead feature	0xAA	R
	0xEF	non	Disable Free-fall control feature set	0xC1	R
Set Max Address	0xF9	non	—	—	R
Set Max Address EXT	0x37	non	—	—	R
Set Multiple	0xC6	non	—	—	R
Sleep	0x99	non	—	—	W
Sleep	0xE6	non	—	—	W
SMART Function Set	0xB0	non	↓	↓	↓
	0xB0	non	Read Attribute Value	0xD0	R
	0xB0	non	Read Attribute Threshold	0xD1	R
	0xB0	non	Enable/Disable Attribute Auto save	0xD2	R
	0xB0	non	Save attribute values	0xD3	R
	0xB0	non	Execute offline immediate	0xD4	W
	0xB0	non	Read log sector	0xD5	R
	0xB0	non	Write log sector	0xD6	W
	0xB0	non	Enable Operations	0xD8	R
	0xB0	non	Disable Operations	0xD9	R
	0xB0	non	Return Status	0xDA	R
	0xB0	non	Enable/Disable Auto Offline	0xDB	R
Standby	0x96	non	—	—	W
Standby	0xE2	non	—	—	W
Standby Immediate	0x94	non	—	—	W
Standby Immediate	0xE0	non	—	—	W
Write Buffer	0xE8	non	—	—	W
Write DMA	0xCA	RW			W
Write DMA w/Retry	0xCB	RW			W
Write DMA EXT	0x35	RW			W
Write DMA FUA EXT	0x3D	RW			W
Write FPDMA Queued	0x61	RW			W
Wwrite Log EXT	0x3F	non	—	—	W
Write Log DMA EXT	0x57	non	—	—	W
Write Multiple	0xC5	RW			W
Write Multiple EXT	0x39	RW			W
Write Multiple FUA EXT	0xCE	RW			W
Write Sectors	0x30	RW			W
Write Sectors w/Retry	0x31	RW			W
Write Sectors EXT	0x34	RW			W
Write Uncorrectable EXT	0x45	non	—	—	W

Table 41 Command Type for Early Drive Ready

13 Command Protocol

The commands are grouped into different classes according to the protocols followed for command execution. The command classes with their associated protocols are defined below.

Please refer to Serial ATA Revision 2.6 (Section 11. device command layer protocol) about each protocol.

For all commands, the host must first check if BSY=1, and should proceed no further unless and until BSY=0. For all commands, the host must also wait for RDY=1 before proceeding.

A device must maintain either BSY=1 or DRQ=1 at all times until the command is completed. The INTRQ signal is used by the device to signal most, but not all, times when the BSY bit is changed from 1 to 0 during command execution.

A command shall only be interrupted with a COMRESET or software reset. The result of writing to the Command register while BSY=1 or DRQ=1 is unpredictable and may result in data corruption. A command should only be interrupted by a reset at times when the host thinks there may be a problem, such as a device that is no longer responding.

Interrupts are cleared when the host reads the Status Register, issues a reset, or writes to the Command Register.

“Table 143 Timeout Values” on Page171 shows the device timeout values.

13.1 Data In Commands

These commands are:

- Device Configuration Identify
- Identify Device
- Read Buffer
- Read Log Ext
- Read Multiple
- Read Multiple Ext
- Read Sector(s)
- Read Sector(s) Ext
- S.M.A.R.T. Read Attribute Values
- S.M.A.R.T. Read Attribute Thresholds
- S.M.A.R.T. Read log sector

Execution includes the transfer of one or more 512 byte (>512 bytes on Read Long) sectors of data from the device to the host.

Note that the status data for a sector of data is available in the Status Register **before** the sector is transferred to the host.

If the device detects an invalid parameter, then it will abort the command by setting BSY=0, ERR=1, ABT=1.

If an error occurs, the device will set BSY=0, ERR=1, and DRQ=1. The device will then store the error status in the Error Register. The registers will contain the location of the sector in error. The erroneous location will be reported with CHS mode or LBA mode, the mode is decided by mode select bit (bit 6) of Device register on issuing the command.

13.2 Data Out Commands

These commands are:

- Device Configuration Set
- Download Microcode
- Format Track
- Security Disable Password
- Security Erase Unit
- Security Set Password
- Security Unlock
- Set Max Set Password
- Set Max Unlock
- S.M.A.R.T Write Log Sector
- Write Buffer
- Write Log Ext
- Write Multiple
- Write Multiple Ext
- Write Multiple FUA Ext
- Write Sector(s)
- Write Sector(s) Ext

Execution includes the transfer of one or more 512 byte (>512 bytes on Write Long) sectors of data from the host to the device.

If the device detects an invalid parameter, then it will abort the command by setting BSY=0, ERR=1, ABT=1.

If an uncorrectable error occurs, the device will set BSY=0 and ERR=1, store the error status in the Error Register. The registers will contain the location of the sector in error. The errored location will be reported with CHS mode or LBA mode. The mode is decided by mode select bit (bit 6) of Device register on issuing the command.

13.3 Non-Data Commands

These commands are:

- Check Power Mode
- Device Configuration Freeze Lock
- Device Configuration Restore
- Execute Device Diagnostic
- Flush Cache
- Flush Cache Ext
- Format Unit
- Idle
- Idle Immediate
- Idle Immediate with Unload option
- Initialize Device Parameters
- Read Native Max Address
- Read Native Max Address Ext
- Read Verify Sector(s)
- Read Verify Sector(s) Ext
- Recalibrate
- Security Erase Prepare
- Security Freeze Lock
- Seek
- Sense Condition
- Set Features
- Set Max Address
- Set Max Address Ext
- Set Max Lock
- Set Max Freeze Lock
- Set Multiple Mode
- Sleep
- S.M.A.R.T. Disable Operations
- S.M.A.R.T. Enable/Disable Attribute Autosave
- S.M.A.R.T. Enable/Disable Automatic Off-line
- S.M.A.R.T. Enable Operations

- S.M.A.R.T. Execute Off-line Immediate
- S.M.A.R.T. Return Status
- S.M.A.R.T. Save Attribute Values
- Standby
- Standby Immediate
- Write Uncorrectable Ext

Execution of these commands involves no data transfer.

13.4 DMA Data Transfer Commands

These commands are:

- Read DMA
- Read DMA Ext
- Read Log DMA Ext
- Write DMA
- Write DMA Ext
- Write Log DMA Ext
- Write DMA FUA Ext

Initiation of the DMA transfer commands is identical to the Read Sector or Write Sector commands except that the host initializes the slave-DMA channel prior to issuing the command.

The DMA protocol allows high performance multi-tasking operating systems to eliminate processor overhead associated with PIO transfers.

Refer Functional Specification part for further details.

13.5 First-parity DMA Commands

These commands are:

- Read FPDMA Queued
- Write FPDMA Queued

Execution of this class of commands includes command queuing and the transfer of one or more blocks of data between the device and the host. The protocol is described in the section 11.14 “FPDMA Queued command protocol” of “Serial ATA revision 2.6”.

14 Command Descriptions

Protocol	Command	Code								
		(Hex)	7	6	5	4	3	2	1	0
3	Check Power Mode	E5	1	1	1	0	0	1	0	1
3	Check Power Mode*	98	1	0	0	1	1	0	0	0
3	Device Configuration Restore	B1	1	0	1	0	0	0	0	1
3	Device Configuration Freeze Lock	B1	1	0	1	0	0	0	0	1
1	Device Configuration Identify	B1	1	0	1	0	0	0	0	1
2	Device Configuration Set	B1	1	0	1	0	0	0	0	1
2	Download Microcode	92	1	0	0	1	0	0	1	0
3	Execute Device Diagnostic	90	1	0	0	1	0	0	0	0
3	Flush Cache	E7	1	1	1	0	0	1	1	1
3	Flush Cache Ext	EA	1	1	1	0	1	0	1	0
2	Format Track	50	0	1	0	1	0	0	0	0
3+	Format Unit	F7	1	1	1	1	0	1	1	1
1	Identify Device	EC	1	1	1	0	1	1	0	0
3	Idle	E3	1	1	1	0	0	0	1	1
3	Idle*	97	1	0	0	1	0	1	1	1
3	Idle Immediate	E1	1	1	1	0	0	0	0	1
3	Idle Immediate*	95	1	0	0	1	0	1	0	1
3	Idle Immediate with Unload option	E1	1	1	1	0	0	0	0	1
3	Initialize Device Parameters	91	1	0	0	1	0	0	0	1
1	Read Buffer	E4	1	1	1	0	0	1	0	0
4	Read DMA	C8	1	1	0	0	1	0	0	0
4	Read DMA	C9	1	1	0	0	1	0	0	1
4	Read DMA Ext	25	0	0	1	0	0	1	0	1
5	Read FPDMA Queued	60	0	1	1	0	0	0	0	0
1	Read Log Ext	2F	0	0	1	0	1	1	1	1
4	Read Log DMA Ext	47	0	1	0	0	0	1	1	1
1	Read Multiple	C4	1	1	0	0	0	1	0	0
1	Read Multiple Ext	29	0	0	1	0	1	0	0	1
3	Read Native Max Address	F8	1	1	1	1	1	0	0	0
3	Read Native Max Address Ext	27	0	0	1	0	0	1	1	1
1	Read Sector(s)	20	0	0	1	0	0	0	0	0
1	Read Sector(s)	21	0	0	1	0	0	0	0	1
1	Read Sector(s) Ext	24	0	0	1	0	0	1	0	0
3	Read Verify Sector(s)	40	0	1	0	0	0	0	0	0
3	Read Verify Sector(s)	41	0	1	0	0	0	0	0	1
3	Read Verify Sector(s) Ext	42	0	1	0	0	0	0	1	0
3	Recalibrate	1x	0	0	0	1	-	-	-	-
2	Security Disable Password	F6	1	1	1	1	1	0	1	0
3	Security Erase Prepare	F3	1	1	1	1	0	0	1	1
2	Security Erase Unit	F4	1	1	1	1	0	1	0	0
3	Security Freeze Lock	F5	1	1	1	1	0	1	0	1
2	Security Set Password	F1	1	1	1	1	0	0	0	1
2	Security Unlock	F2	1	1	1	1	0	0	1	0
3	Seek	7x	0	1	1	1	-	-	-	-
3+	Sense Condition	F0	1	1	1	1	0	0	0	0
3	Set Features	EF	1	1	1	0	1	1	1	1

Table 42 Command set

Protocol	Command	Code								
		(Hex)	7	6	5	4	3	2	1	0
3	Set Max Address	F9	1	1	1	1	1	0	0	1
3	Set Max Address Ext	37	0	0	1	1	0	1	1	1
3	Set Max Freeze Lock	F9	1	1	1	1	1	0	0	1
3	Set Max Lock	F9	1	1	1	1	1	0	0	1
2	Set Max Set Password	F9	1	1	1	1	1	0	0	1
2	Set Max Unlock	F9	1	1	1	1	1	0	0	1
3	Set Multiple Mode	C6	1	1	0	0	0	1	1	0
3	Sleep	E6	1	1	1	0	0	1	1	0
3	Sleep*	99	1	0	0	1	1	0	0	1
3	S.M.A.R.T. Disable Operations	B0	1	0	1	1	0	0	0	0
3	S.M.A.R.T. Enable/Disable Attribute Auto save	B0	1	0	1	1	0	0	0	0
3	S.M.A.R.T. Enable/Disable Automatic Off-line	B0	1	0	1	1	0	0	0	0
3	S.M.A.R.T. Enable Operations	B0	1	0	1	1	0	0	0	0
3	S.M.A.R.T. Execute Off-line Immediate	B0	1	0	1	1	0	0	0	0
1	S.M.A.R.T. Read Attribute Values	B0	1	0	1	1	0	0	0	0
1	S.M.A.R.T. Read Attribute Thresholds	B0	1	0	1	1	0	0	0	0
1	S.M.A.R.T. Read Log Sector	B0	1	0	1	1	0	0	0	0
3	S.M.A.R.T. Return Status	B0	1	0	1	1	0	0	0	0
3	S.M.A.R.T. Save Attribute Values	B0	1	0	1	1	0	0	0	0
2	S.M.A.R.T. Write Log Sector	B0	1	0	1	1	0	0	0	0
3	Standby	E2	1	1	1	0	0	0	1	0
3	Standby*	96	1	0	0	1	0	1	1	0
3	Standby Immediate	E0	1	1	1	0	0	0	0	0
3	Standby Immediate*	94	1	0	0	1	0	1	0	0
2	Write Buffer	E8	1	1	1	0	1	0	0	0
4	Write DMA	CA	1	1	0	0	1	0	1	0
4	Write DMA	CB	1	1	0	0	1	0	1	1
4	Write DMA Ext	35	0	0	1	1	0	1	0	1
4	Write DMA FUA Ext	3D	0	0	1	1	1	1	0	1
5	Write FPDMA Queued	61	0	1	1	0	0	0	0	1
2	Write Log Ext	3F	0	0	1	1	1	1	1	1
4	Write Log DMA Ext	57	0	1	0	1	0	1	1	1
2	Write Multiple	C5	1	1	0	0	0	1	0	1
2	Write Multiple Ext	39	0	0	1	1	1	0	0	1
2	Write Multiple FUA Ext	CE	1	1	0	0	1	1	1	0
2	Write Sector(s)	30	0	0	1	1	0	0	0	0
2	Write Sector(s)	31	0	0	1	1	0	0	0	1
2	Write Sector(s) Ext	34	0	0	1	1	0	1	0	0
3	Write Uncorrectable Ext	45	0	1	0	0	0	1	0	1

Protocol : 1 : PIO data IN command
 2 : PIO data OUT command
 3 : Non data command
 4 : DMA command
 5 : First-parity DMA command

+ : Vendor specific command

Table 43 Command Set - continued

Commands marked * are alternate command codes for previously defined commands.

Command (Subcommand)	Command code (Hex)	Feature Register (Hex)
(S.M.A.R.T Function)		
S.M.A.R.T. Read Attribute Values	B0	D0
S.M.A.R.T. Read Attribute Thresholds	B0	D1
S.M.A.R.T. Enable/Disable Attribute Autosave	B0	D2
S.M.A.R.T. Save Attribute Values	B0	D3
S.M.A.R.T. Execute Off-line Immediate	B0	D4
S.M.A.R.T. Read Log Sector	B0	D5
S.M.A.R.T. Write Log Sector	B0	D6
S.M.A.R.T. Enable Operations	B0	D8
S.M.A.R.T. Disable Operations	B0	D9
S.M.A.R.T. Return Status	B0	DA
S.M.A.R.T. Enable/Disable Automatic Off-line	B0	DB
(Set Features)		
Enable Write Cache	EF	02
Set Transfer Mode	EF	03
Enable Advanced Power Management feature	EF	05
Enable Power-Up in Standby feature	EF	06
Power-Up in Standby feature device Spin-Up	EF	07
Enable use of Serial ATA feature	EF	10
Disable read look-ahead feature	EF	55
Disable write cache	EF	82
Disable Advanced Power Management feature	EF	85
Disable Power-Up in Standby feature	EF	86
Disable use of Serial ATA feature	EF	90
Enable read look-ahead feature	EF	AA
(Set Max security extension)		
Set Max Set Password	F9	01
Set Max Lock	F9	02
Set Max Unlock	F9	03
Set Max Freeze Lock	F9	04
(Device Configuration Overlay)		
Device Configuration Restore	B1	C0
Device Configuration Freeze Lock	B1	C1
Device Configuration Identify	B1	C2
Device Configuration Set	B1	C3

Table 44 Command Set (Subcommand)

“Table 42 Command set” on Page 73 shows the commands that are supported by the device. “ Table 44 Command Set (Subcommand)” on Page75 shows the sub-commands that are supported by each command or feature.

The following symbols are used in the command descriptions:

Output Registers

- 0** Indicates that the bit must be set to 0.
- 1** Indicates that the bit must be set to 1.
- H** Head number. Indicates that the head number part of the Device Register is an output parameter and should be specified.
- L** LBA mode. Indicates the addressing mode. Zero specifies CHS mode and one does LBA addressing mode.
- R** Retry. Original meaning is already obsolete, there is no difference between 0 and 1. (Using 0 is recommended for future compatibility.)
- B** Option Bit. Indicates that the Option Bit of the Sector Count Register should be specified. (This bit is used by Set Max ADDRESS command)
- V** Valid. Indicates that the bit is part of an output parameter and should be specified.
- X** Indicates that the hex character is not used.
- Indicates that the bit is not used.

Input Registers

- 0** Indicates that the bit is always set to 0.
- 1** Indicates that the bit is always set to 1.
- H** Head number. Indicates that the head number part of the Device Register is an input parameter and will be set by the device.
- V** Valid. Indicates that the bit is part of an input parameter and will be set to 0 or 1 by the device.
- N** Not recommendable condition for start up. Indicates that the condition of device is not recommendable for start up.
- Indicates that the bit is not part of an input parameter.

The command descriptions show the contents of the Status and Error Registers after the device has completed processing the command.

14.1 Check Power Mode (E5h/98h)

Command Block Output Registers								Command Block Input Registers									
Register	7	6	5	4	3	2	1	0	Register	7	6	5	4	3	2	1	0
Data	-	-	-	-	-	-	-	-	Data	-	-	-	-	-	-	-	-
Feature	-	-	-	-	-	-	-	-	Error	...See Below...							
Sector Count	-	-	-	-	-	-	-	-	Sector Count	V	V	V	V	V	V	V	V
LBA Low	-	-	-	-	-	-	-	-	LBA Low	-	-	-	-	-	-	-	-
LBA Mid	-	-	-	-	-	-	-	-	LBA Mid	-	-	-	-	-	-	-	-
LBA High	-	-	-	-	-	-	-	-	LBA High	-	-	-	-	-	-	-	-
Device	-	-	-	-	-	-	-	-	Device	-	-	-	-	-	-	-	-
Command	1	1	1	0	0	1	0	1	Status	...See Below...							

Error Register								Status Register							
7	6	5	4	3	2	1	0	7	6	5	4	3	2	1	0
CRC	UNC	0	IDN	0	ABT	T0N	AMN	BSY	RDY	DF	DSC	DRQ	COR	IDX	ERR
0	0	0	0	0	V	0	0	0	0	0	-	-	0	0	V

Table 45 Check Power Mode Command (E5h/98h)

The Check Power Mode command will report whether the device is spun up and the media is available for immediate access.

Input Parameters From The Device

Sector Count The power mode code. The command returns FFh in the Sector Count Register if the spindle motor is at speed and the device is not in Standby or Sleep mode. Otherwise, the Sector Count Register will be set to 0.

14.2 Device Configuration Overlay (B1h)

Command Block Output Registers								Command Block Input Registers									
Register	7	6	5	4	3	2	1	0	Register	7	6	5	4	3	2	1	0
Data	-	-	-	-	-	-	-	-	Data	-	-	-	-	-	-	-	-
Feature	1	0	1	0	V	V	V	V	Error	...See Below...							
Sector Count	-	-	-	-	-	-	-	-	Sector Count	V	V	V	V	V	V	V	V
LBA Low	-	-	-	-	-	-	-	-	LBA Low	-	-	-	-	-	-	-	-
LBA Mid	-	-	-	-	-	-	-	-	LBA Mid	V	V	V	V	V	V	V	V
LBA High	-	-	-	-	-	-	-	-	LBA High	V	V	V	V	V	V	V	V
Device	-	-	-	-	-	-	-	-	Device	-	-	-	-	-	-	-	-
Command	1	0	1	1	0	0	0	1	Status	...See Below...							

Error Register								Status Register							
7	6	5	4	3	2	1	0	7	6	5	4	3	2	1	0
CRC	UNC	0	IDN	0	ABT	T0N	AMN	BSY	RDY	DF	DSC	DRQ	COR	IDX	ERR
0	0	0	0	0	V	0	0	V	V	0	-	V	-	0	V

Table 46 Device Configuration Overlay Command (B1h)

Individual Device Configuration Overlay feature set commands are identified by the value placed in the Features register. The table below shows these Features register values.

Value	Command
C0h	DEVICE CONFIGURATION RESTORE
C1h	DEVICE CONFIGURATION FREEZE LOCK
C2h	DEVICE CONFIGURATION IDENTIFY
C3h	DEVICE CONFIGURATION SET
other	Reserved

Table 47 Device Configuration Overlay Features register values

14.2.1 DEVICE CONFIGURATION RESTORE (subcommand C0h)

The DEVICE CONFIGURATION RESTORE command discard any setting previously made by a DEVICE CONFIGURATION SET command and return the content of the IDENTIFY DEVICE command response to the original settings as indicated by the data returned from the execution of a DEVICE CONFIGURATION IDENTIFY command.

14.2.2 DEVICE CONFIGURATION FREEZE LOCK (subcommand C1h)

The DEVICE CONFIGURATION FREEZE LOCK command prevents accidental modification of the Device Configuration Overlay settings. After successful execution of a DEVICE CONFIGURATION FREEZE LOCK command, all DEVICE CONFIGURATION SET, DEVICE CONFIGURATION FREEZE LOCK, DEVICE CONFIGURATION IDENTIFY, and DEVICE CONFIGURATION RESTORE commands are aborted by the device. The DEVICE CONFIGURATION FREEZE LOCK condition shall be cleared by a power-down. The DEVICE CONFIGURATION FREEZE LOCK condition shall not be cleared by COMRESET or software reset.

14.2.3 DEVICE CONFIGURATION IDENTIFY (subcommand C2h)

The DEVICE CONFIGURATION IDENTIFY command returns a 512 byte data structure via PIO data-in transfer. The content of this data structure indicates the selectable commands, modes, and feature sets that the device is capable of supporting. If a DEVICE CONFIGURATION SET command has been issued reducing the capabilities, the response to an IDENTIFY DEVICE or IDENTIFY PACKET DEVICE command will reflect the reduced set of capabilities, while the DEVICE CONFIGURATION IDENTIFY command will reflect the entire set of selectable capabilities.

The format of the Device Configuration Overlay data structure is shown on next page.

14.2.4 DEVICE CONFIGURATION SET (subcommand C3h)

The DEVICE CONFIGURATION SET command allows a device manufacturer or a personal computer system manufacturer to reduce the set of optional commands, modes, or feature sets supported by a device as indicated by a DEVICE CONFIGURATION IDENTIFY command. The DEVICE CONFIGURATION SET command transfers an overlay that modifies some of the bits set in words 63, 78, 79, 82, 83, 84, and 88 of the IDENTIFY DEVICE command response. When the bits in these words are cleared, the device no longer supports the indicated command, mode, or feature set. If a bit is set in the overlay transmitted by the device that is not set in the overlay received from a DEVICE CONFIGURATION IDENTIFY command, no action is taken for that bit.

The format of the overlay transmitted by the device is described in the table at next page. The restrictions on changing these bits are described in the text following that table. If any of the bit modification restrictions described are violated or any setting is changed with DEVICE CONFIGURATION SET command, the device shall return command aborted. At that case, error reason code is returned to sector count register, invalid word location is returned to LBA High register, and invalid bit location is returned to LBA Mid register. The Definition of error information is shown on the next page.

ERROR INFORMATION EXAMPLE 1:

After establish a protected area with SET MAX address, if a user attempts to execute DC SET or DC RESTORE, device abort that command and return error reason code as below.

LBA High	: 03h	= word 3 is invalid
LBA Mid	: 00h	this register is not assigned in this case
Sector count	: 06h	= Protected area is now established

ERROR INFORMATION EXAMPLE 2:

When device is enabled the Security feature set, if user attempts to disable that feature, device abort that command and return error reason code as below.

LBA High	: 07h	= word 7 is invalid
LBA Mid	: 08h	= bit 3 is invalid
Sector count	: 04h	= now Security feature set is enabled

Word	Content	
0	0002h	Data Structure revision
1	Multiword DMA modes supported	
	15-3	Reserved
	2	1 = Multiword DMA mode 2 and below are supported
	1	1 = Multiword DMA mode 1 and below are supported
	0	1 = Multiword DMA mode 0 is supported
2	Ultra DMA modes supported	
	15-6	Reserved
	5	1 = Ultra DMA mode 5 and below are supported
	4	1 = Ultra DMA mode 4 and below are supported
	3	1 = Ultra DMA mode 3 and below are supported
	2	1 = Ultra DMA mode 2 and below are supported
	1	1 = Ultra DMA mode 1 and below are supported
	0	1 = Ultra DMA mode 0 is supported
3-6	Maximum LBA address	
7	Command set/feature set supported	
	15-9	Reserved
	8	1 = 48-bit Addressing feature set supported
	7	1 = Host Protected Area feature set supported
	6	Reserved
	5	Reserved
	4	1 = Power-Up in Standby feature set supported
	3	1 = Security feature set supported
	2	1 = SMART error log supported
	1	1 = SMART self-test supported
	0	1 = SMART feature set supported
8	SATA feature	
	15-5	Reserved
	4	1 = Software setting preservation supported
	3	Reserved
	2	1 = Interface power management supported
	1	1 = Non-zero buffer offset in DMA Setup FIS supported
	0	1 = Native command queuing supported
9-254	Reserved	
255	Integrity word <Note .>	
	15-8	Checksum
	7-0	Signature (A5h)

Table 48 Device Configuration Overlay Data structure

Note.

Bits 7:0 of this word contain the value A5h. Bits 15:8 of this word contain the data structure checksum. The data structure checksum is the two's complement of the sum of all byte in words 0 through 254 and the byte consisting of bits 7:0 of word 255. Each byte is added with unsigned arithmetic, and overflow is ignored. The sum of all bytes is zero when the checksum is correct.

LBA High	invalid word location	
LBA Mid	invalid bit location (bits (7:0))	
LBA Low	invalid bit location (bits (15:8))	
Sector count	error reason code & description	
	01h	DCO feature is frozen
	02h	Device is now Security Locked mode
	03h	Device's feature is already modified with DCO
	04h	User attempt to disable any feature enabled
	05h	Device is now SET MAX Locked or Frozen mode
	06h	Protected area is now established
	07h	DCO is not supported
	08h	Subcommand code is invalid
	FFh	other reason

Table 49 DCO error information definition

14.3 Download Microcode (92h)

Command Block Output Registers								Command Block Input Registers									
Register	7	6	5	4	3	2	1	0	Register	7	6	5	4	3	2	1	0
Data	-	-	-	-	-	-	-	-	Data	-	-	-	-	-	-	-	-
Feature	V	V	V	V	V	V	V	V	Error	...See Below...							
Sector Count	V	V	V	V	V	V	V	V	Sector Count	-	-	-	-	-	-	-	-
LBA Low	V	V	V	V	V	V	V	V	LBA Low	-	-	-	-	-	-	-	-
LBA Mid	V	V	V	V	V	V	V	V	LBA Mid	-	-	-	-	-	-	-	-
LBA High	V	V	V	V	V	V	V	V	LBA High	-	-	-	-	-	-	-	-
Device	-	-	-	-	-	-	-	-	Device	-	-	-	-	-	-	-	-
Command	1	0	0	1	0	0	1	0	Status	...See Below...							

Error Register								Status Register							
7	8	9	10	3	2	1	0	7	6	5	4	3	2	1	0
CRC	UNC	0	IDN	0	ABT	T0N	AMN	BSY	RDY	DF	DSC	DRQ	COR	IDX	ERR
0	V	0	0	0	V	0	0	0	1	0	1	-	0	0	V

Table 50 Download Command (92h)

Output Parameters To The Device

Feature	Subcommand code. 03h : Download and save microcode with offsets. 07h : Download and save microcode. Other values are reserved.
Sector Count	Lower byte of 16-bit sector count value to transfer from the host.
LBA Low	Higher byte of 16-bit sector count value to transfer from the host.
LBA High/Mid	Buffer offset (only used for Feature = 03h)

This command enables the host to alter the device's microcode. The data transferred using the DOWNLOAD MICROCODE commands is vendor specific.

All transfers shall be an integer multiple of the sector size. The size of the data transfer is determined by the contents of the LBA Low and Sector Count registers. The LBA Low register is used to extend the Sector Count register to create a 16-bit sector count value. The LBA Low register is the most significant eight bits and the Sector Count register is the least significant eight bits.

ABT will be set to 1 in the Error Register if the value in the Feature register is neither 03h nor 07h, or the device is in Security Locked mode. When the reload of new microcode is requested in the data sent by the host for this Download command, UNC error will be set to 1 in the Error Register if the device fails to reload new microcode.

In reloading new microcode, when the spin-up of the device is disabled, the device spins down after reloading new microcode.

A Features register value of 03h indicates that the microcode will be transferred in one or more Download Microcode commands using the offset transfer method. The buffer offset value is starting location in the microcode file, which varies in 512 byte increments. It is defined by the LBA High and LBA Mid registers. The LBA High register is the most significant eight bits and the LBA Mid register is the least significant eight bits of the buffer offset value.

All microcode segments shall be sent to the device in sequence.

The device will abort the DOWNLOAD MICROCODE command and discard all previously downloaded microcode, if the current buffer offset is not equal to the sum of the previous DOWNLOAD MICROCODE command buffer offset and the previous sector count. The first DOWNLOAD MICROCODE command shall have a buffer offset of zero.

The new firmware becomes effective immediately after the transfer of the last data segment has completed.

When the device detects the last download microcode command for the firmware download the device will perform any device required verification and save the complete set of downloaded microcode.

If the device receives a command other than download microcode prior to the receipt of the last segment the new command is executed and all previously downloaded microcode is discarded.

If a software or hardware Reset is issued to the device before all of the microcode segments have been transferred to the device the device shall abandon all of the microcode segments received and process the Reset.

14.4 Execute Device Diagnostic (90h)

Command Block Output Registers								Command Block Input Registers									
Register	7	6	5	4	3	2	1	0	Register	7	6	5	4	3	2	1	0
Data	-	-	-	-	-	-	-	-	Data	-	-	-	-	-	-	-	-
Feature	-	-	-	-	-	-	-	-	Error	...See Below...							
Sector Count	-	-	-	-	-	-	-	-	Sector Count	-	-	-	-	-	-	-	-
LBA Low	-	-	-	-	-	-	-	-	LBA Low	-	-	-	-	-	-	-	-
LBA Mid	-	-	-	-	-	-	-	-	LBA Mid	-	-	-	-	-	-	-	-
LBA High	-	-	-	-	-	-	-	-	LBA High	-	-	-	-	-	-	-	-
Device	-	-	-	-	-	-	-	-	Device	-	-	-	-	-	-	-	-
Command	1	0	0	1	0	0	0	0	Status	...See Below...							

Error Register								Status Register							
7	6	5	4	3	2	1	0	7	6	5	4	3	2	1	0
CRC	UNC	0	IDN	0	ABT	T0N	AMN	BSY	RDY	DF	DSC	DRQ	COR	IDX	ERR
0	V	V	V	V	V	V	V	0	0	0	-	-	0	0	0

Table 51 Execute Device Diagnostic Command (90h)

The Execute Device Diagnostic command performs the internal diagnostic tests implemented by the device. The results of the test are stored in the Error Register.

The normal Error Register bit definitions do not apply to this command. Instead, the register contains a diagnostic code. See "Table 31 Diagnostic Codes" on Page46 for the definition.

14.5 Flush Cache (E7h)

Command Block Output Registers								Command Block Input Registers									
Register	7	6	5	4	3	2	1	0	Register	7	6	5	4	3	2	1	0
Data	-	-	-	-	-	-	-	-	Data	-	-	-	-	-	-	-	-
Feature	-	-	-	-	-	-	-	-	Error	...See Below...							
Sector Count	-	-	-	-	-	-	-	-	Sector Count	-	-	-	-	-	-	-	-
LBA Low	-	-	-	-	-	-	-	-	LBA Low	-	-	-	-	-	-	-	-
LBA Mid	-	-	-	-	-	-	-	-	LBA Mid	-	-	-	-	-	-	-	-
LBA High	-	-	-	-	-	-	-	-	LBA High	-	-	-	-	-	-	-	-
Device	-	-	-	-	-	-	-	-	Device	-	-	-	-	-	-	-	-
Command	1	1	1	0	0	1	1	1	Status	...See Below...							

Error Register								Status Register							
7	6	5	4	3	2	1	0	7	6	5	4	3	2	1	0
CRC	UNC	0	IDN	0	ABT	T0N	AMN	BSY	RDY	DF	DSC	DRQ	COR	IDX	ERR
0	0	0	0	0	V	0	0	0	V	0	V	-	0	0	V

Table 52 Flush Cache Command (E7h)

This command causes the device to complete writing data from its cache.

The device returns a status, RDY=1 and DSC=1 (50h), after following sequence.

- Data in the write cache buffer is written to disk media.
- Return a successfully completion.

14.6 Flush Cache Ext (EAh)

Command Block Output Registers									Command Block Input Registers										
Register		7	6	5	4	3	2	1	0	Register		7	6	5	4	3	2	1	0
Data Low		-	-	-	-	-	-	-	-	Data Low		-	-	-	-	-	-	-	-
Data High		-	-	-	-	-	-	-	-	Data High		-	-	-	-	-	-	-	-
Feature	Current	-	-	-	-	-	-	-	-	Error		...See Below...							
	Previous	-	-	-	-	-	-	-	-										
Sector Count	Current	-	-	-	-	-	-	-	-	Sector Count	HOB=0	-	-	-	-	-	-	-	-
	Previous	-	-	-	-	-	-	-	-		HOB=1	-	-	-	-	-	-	-	-
LBA Low	Current	-	-	-	-	-	-	-	-	LBA Low	HOB=0	-	-	-	-	-	-	-	-
	Previous	-	-	-	-	-	-	-	-		HOB=1	-	-	-	-	-	-	-	-
LBA Mid	Current	-	-	-	-	-	-	-	-	LBA Mid	HOB=0	-	-	-	-	-	-	-	-
	Previous	-	-	-	-	-	-	-	-		HOB=1	-	-	-	-	-	-	-	-
LBA High	Current	-	-	-	-	-	-	-	-	LBA High	HOB=0	-	-	-	-	-	-	-	-
	Previous	-	-	-	-	-	-	-	-		HOB=1	-	-	-	-	-	-	-	-
Device		-	-	-	-	-	-	-	-	Device		-	-	-	-	-	-	-	-
Command		1	1	1	0	1	0	1	0	Status		...See Below...							

Error Register								Status Register							
7	6	5	4	3	2	1	0	7	6	5	4	3	2	1	0
CRC	UNC	0	IDN	0	ABT	TON	AMN	BSY	RDY	DF	DSC	DRQ	COR	IDX	ERR
0	0	0	0	0	V	0	0	0	V	0	V	-	0	0	V

Table 53 Flush Cache EXT Command (EAh)

This command causes the device to complete writing data from its cache.

The device returns good status after data in the write cache is written to disk media.

14.7 Format Track (50h: Vendor Specific)

Command Block Output Registers								Command Block Input Registers									
Register	7	6	5	4	3	2	1	0	Register	7	6	5	4	3	2	1	0
Data	-	-	-	-	-	-	-	-	Data	-	-	-	-	-	-	-	-
Feature	-	-	-	-	-	-	-	-	Error	...See Below...							
Sector Count	-	-	-	-	-	-	-	-	Sector Count	-	-	-	-	-	-	-	-
LBA Low	V	V	V	V	V	V	V	V	LBA Low	V	V	V	V	V	V	V	V
LBA Mid	V	V	V	V	V	V	V	V	LBA Mid	V	V	V	V	V	V	V	V
LBA High	V	V	V	V	V	V	V	V	LBA High	V	V	V	V	V	V	V	V
Device	-	L	-	-	H	H	H	H	Device	-	-	-	-	H	H	H	H
Command	0	1	0	1	0	0	0	0	Status	...See Below...							

Error Register								Status Register							
7	6	5	4	3	2	1	0	7	6	5	4	3	2	1	0
CRC	UNC	0	IDN	0	ABT	T0N	AMN	BSY	RDY	DF	DSC	DRQ	COR	IDX	ERR
0	0	0	V	0	V	0	0	0	V	0	V	-	0	0	V

Table 54 Format Track Command (50h)

The Format Track command formats a single logical track on the device. Each good sector of data on the track will be initialized to zero with write operation. At this time, whether the sector of data is initialized correctly is not verified with read operation. Any data previously stored on the track will be lost.

Output Parameters To The Device

LBA Low In LBA mode, this register specifies LBA address bits 0 - 7 to be formatted. (L=1)

LBA High/Mid The cylinder number of the track to be formatted. (L=0)
In LBA mode, this register specifies LBA address bits 8 - 15 (Mid), 16 - 23 (High) to be formatted. (L=1)

H The head number of the track to be formatted. (L=0)
In LBA mode, this register specifies LBA address bits 24 - 27 to be formatted. (L=1)

Input Parameters From The Device

LBA Low In LBA mode, this register specifies current LBA address bits 0-7. (L=1)

LBA High/Mid In LBA mode, this register specifies current LBA address bits 8 - 15 (Mid), 16 - 23 (High)

H In LBA mode, this register specifies current LBA address bits 24 - 27. (L=1)

In LBA mode, this command formats a single logical track including the specified LBA.

14.8 Format Unit (F7h: Vendor Specific)

Command Block Output Registers								Command Block Input Registers									
Register	7	6	5	4	3	2	1	0	Register	7	6	5	4	3	2	1	0
Data	-	-	-	-	-	-	-	-	Data	-	-	-	-	-	-	-	-
Feature	V	V	V	V	V	V	V	V	Error	...See Below...							
Sector Count	-	-	-	-	-	-	-	-	Sector Count	-	-	-	-	-	-	-	-
LBA Low	-	-	-	-	-	-	-	-	LBA Low	-	-	-	-	-	-	-	-
LBA Mid	-	-	-	-	-	-	-	-	LBA Mid	-	-	-	-	-	-	-	-
LBA High	-	-	-	-	-	-	-	-	LBA High	-	-	-	-	-	-	-	-
Device	-	-	-	-	-	-	-	-	Device	-	-	-	-	-	-	-	-
Command	1	1	1	1	0	1	1	1	Status	...See Below...							

Error Register								Status Register							
7	8	9	10	3	2	1	0	7	6	5	4	3	2	1	0
CRC	UNC	0	IDN	0	ABT	T0N	AMN	BSY	RDY	DF	DSC	DRQ	COR	IDX	ERR
0	0	0	V	0	V	0	0	0	V	0	V	-	0	0	V

Table 55 Format Unit Command (F7h)

The Format Unit command initializes all user data sectors after merging reassigned sector location into the defect information of the device and clearing the reassign information. Both new reassign information and new defect information are available right after this command completion, and are also used on next power on reset. Both previous information are erased from the device by this command.

Note that the Format Unit command initializes from LBA 0 to Native MAX LBA. Host MAX LBA set by Initialize Drive Parameter or Set MAX ADDRESS command is ignored. So the protected area by Set MAX ADDRESS commands is also initialized.

The security erase prepare command should be completed immediately prior to the Format Unit command. If the device receives a Format Unit command without a prior Security Erase Prepare command the device aborts the Format Unit command.

If Feature register is NOT 11h, the device returns Abort error to the host.

This command does not request to data transfer.

Output Parameters To The Device

Feature Destination code for this command
11H Merge reassigned location into the defect information

The execution time of this command depends on drive capacity. To determine command timeout value, Word 89 of Identify Device data should be referred..

14.9 Identify Device (ECh)

Command Block Output Registers								Command Block Input Registers									
Register	7	6	5	4	3	2	1	0	Register	7	6	5	4	3	2	1	0
Data	-	-	-	-	-	-	-	-	Data	-	-	-	-	-	-	-	-
Feature	-	-	-	-	-	-	-	-	Error	...See Below...							
Sector Count	-	-	-	-	-	-	-	-	Sector Count	-	-	-	-	-	-	-	-
LBA Low	-	-	-	-	-	-	-	-	LBA Low	-	-	-	-	-	-	-	-
LBA Mid	-	-	-	-	-	-	-	-	LBA Mid	-	-	-	-	-	-	-	-
LBA High	-	-	-	-	-	-	-	-	LBA High	-	-	-	-	-	-	-	-
Device	-	-	-	-	-	-	-	-	Device	-	-	-	-	-	-	-	-
Command	1	1	1	0	1	1	0	0	Status	...See Below...							

Error Register								Status Register							
7	6	5	4	3	2	1	0	7	6	5	4	3	2	1	0
CRC	UNC	0	IDN	0	ABT	T0N	AMN	BSY	RDY	DF	DSC	DRQ	COR	IDX	ERR
0	0	0	0	0	V	0	0	0	V	0	-	-	0	0	V

Table 56 Identify Device Command (ECh)

The Identify Device command requests the device to transfer configuration information to the host. The device will transfer a sector to the host containing the information in “Table 57 Identify device information” on Page90-98.

Word	Content		Description
00	045xH		Drive classification, bit assignments:
			15 (=0): 1=ATAPI device, 0=ATA device
		*	14 (=0): 1=format speed tolerance gap required
		*	13 (=0): 1=track offset option available
		*	12 (=0): 1=data strobe offset option available
		*	11 (=0): 1=rotational speed tolerance > 0.5%
		*	10 (=1): 1=disk transfer rate > 10 Mbps
		*	9 (=0): 1=disk transfer rate > 5 Mbps but <= 10 Mbps
		*	8 (=0): 1=disk transfer rate <= 5 Mbps
			7 (=0): 1=removable cartridge device
			6 (=1): 1=fixed device
		*	5 (=0): 1=spindle motor control option implemented
		*	4 (=1): 1=head switch time > 15 us
		*	3 (=1): 1=not MFM encoded
			2 (=x): 1=Identify data incomplete
		*	1 (=1): 1=hard sectored
			0 (=0): Reserved
01	Note.2		Number of cylinders in default translate mode
02	xxxxh		Specific configuration
			C837h SET FEATURES subcommand is not required to spin-up and IDENTIFY DEVICE response is complete
			8C73h SET FEATURES subcommand is not required to spin-up and IDENTIFY DEVICE response is incomplete
03	Note.2		Number of heads in default translate mode
04-05	0	*	Reserved
06	003FH		Number of sectors per track in default translate mode
07-09	0		Reserved
10-19	XXXX		Serial number in ASCII (0 = not specified)
20	0003H	*	Controller type:
			0003: dual ported, multiple sector buffer with look-ahead read
21	4000H	*	Buffer size in number of sectors
22	00xxH	*	Obsolete
23-26	XXXX		Microcode version in ASCII
27-46	Note.2		Model number in ASCII
47	8010H		Maximum number of sectors that can be transferred per interrupt on Read and Write Multiple commands
			15-8 : (=80h)
			7-0 : Maximum number of sectors that can be transferred per interrupt.

Note.1 The "*" mark in 'Content' field indicates the use of those parameters that are vendor specific.

Table 57 Identify device information

Word	Content	Description
48	4000H	Trusted Computing feature set options
		15(=0) Always 0
		14(=1) Always 1
		13- 1(=0) Reserved
		0(=0) 1=Trusted Computing feature set is supported
49	2F00H	Capabilities, bit assignments:
		15-14 (=0) Reserved
		13 (=1) 1= Standby timer value as specified in ATA standard are supported.
		12 (=0) Reserved
		11 (=1) 1= IORDY Supported
		10 (=1) 1= IORDY can be disabled
		9 (=1) 1=LBA Supported
		8 (=1) 1=DMA Supported
	*	7- 0 (=0) Reserved
50	4000H	Capabilities
		15 (=0) 0=the contents of word 50 are valid
		14 (=1) 1=the contents of word 50 are valid
		13- 2 (=0) Reserved
		1 (=0) Obsolete
		0 (=0) 1=the device has a minimum Standby timer value that is device specific
51	0200H	* PIO data transfer cycle timing mode
52	0200H	* DMA data transfer cycle timing mode Refer Word 62 and 63
53	xx07H	Validity flag of the word
		15- 8 xxh = FFS Sense Level
		7- 3(=0) Reserved
		2(=1) 1=Word 88 is Valid
		1(=1) 1=Word 64-70 are Valid
		0(=1) 1=Word 54-58 are Valid
54	xxxxH	Number of current cylinders
55	xxxxH	Number of current heads
56	xxxxH	Number of current sectors per track
57-58	xxxxH	Current capacity in sectors Word 57 specifies the low word of the capacity
59	0110H	Current Multiple setting. bit assignments
		15- 9 (=0) Reserved
		8 1= Multiple Sector Setting is Valid
		7- 0 xxh = Current setting for number of sectors
60-61	Note.2	Total Number of User Addressable Sectors Word 60 specifies the low word of the number FFFFFFFFh=The 48-bit native max address is greater than 268,435,455
62	0000H	* Reserved

Note.1 The "*" mark in 'Content' field indicates the use of those parameters that are vendor specific.

Note.2 See following table "Table 66 Number of cylinders/heads/sectors by models for HTE5450XXA7E680" on Page99

Table 58 Identify device information --- Continued ---

Word	Content	Description
63	0x07H	Multiword DMA Transfer Capability
		15-11(=0) Reserved
		10 1=Multiword DMA mode 2 is selected
		9 1=Multiword DMA mode 1 is selected
		8 1=Multiword DMA mode 0 is selected
		7- 3 (=0) Reserved
		2 (=1) 1=Multiword DMA mode 2 is supported
		1 (=1) 1=Multiword DMA mode 1 is supported
		0 (=1) 1=Multiword DMA mode 0 is supported
64	0003H	Flow Control PIO Transfer Modes Supported
		15- 8 (=0) Reserved
		7- 0 (=3) Advanced PIO Transfer Modes Supported
		'11' = PIO Mode 3 and 4 Supported
65	0078H	Minimum Multiword DMA Transfer Cycle Time Per Word
		15- 0 (=78h) Cycle time in nanoseconds (120ns, 16.6MB/s)
66	0078H	Manufacturer's Recommended Multiword DMA Transfer Cycle Time
		15- 0 (=78h) Cycle time in nanoseconds (120ns, 16.6MB/s)
67	0078H	Minimum PIO Transfer Cycle Time Without Flow Control
		15- 0 (=78h) Cycle time in nanoseconds (120ns, 16.6MB/s)
68	0078H	Minimum PIO Transfer Cycle Time With IORDY Flow Control
		15- 0 (=78h) Cycle time in nanoseconds (120ns, 16.6MB/s)
69-74	0000H	Reserved
75	001FH	Queue depth
		15-5(=0) Reserved
		4-0(=1Fh) Maximum queued depth - 1
76	170xH	SATA capabilities
		15-13(=0) Reserved
		12(=1) 1=Native Command Queuing priority information supported
		11(=0) 1=Unload while NCQ commands outstanding supported
		10(=1) 1=Phy event counters supported
		9(=1) 1=Receipt of host-initiated interface power management requests supported
		8(=1) 1=Native Command Queuing supported
		7-4(=0) Reserved
		3(=x) 1=SATA Gen-3 speed (6.0Gbps) supported
		2(=x) 1=SATA Gen-2 speed (3.0Gbps) supported
		1(=1) 1=SATA Gen-1 speed (1.5Gbps) supported
		0(=0) Reserved
77	0000H	SATA additional capabilities
		15-4(=0) Reserved
		3-1 Coded value indicating current negotiated SATA signal speed. 011=6.0Gbps 010=3.0Gbps 001=1.5Gbps
		0(=0) Reserved

Note.1 The "*" mark in 'Content' field indicates the use of those parameters that are vendor specific.

Table 59 Identify device information --- Continued ---

Word	Content	Description
78	005EH	SATA supported features
		15-7(=0) Reserved
		6(=1) 1=Software setting preservation supported
		5(=0) Reserved
		4(=1) 1=In-order data delivery supported
		3(=1) 1=Device initiated interface power management supported
		2(=1) 1=DMA Setup Auto-Activate optimization supported
		1(=1) 1=Non-zero buffer offset in DMA Setup FIS supported
		0(=0) Reserved
79	00xxH	SATA enabled features
		15-7(=0) Reserved
		6(=x) 1=Software setting preservation enabled
		5(=0) Reserved
		4(=x) 1=In-order data delivery enabled
		3(=x) 1=Device initiated interface power management enabled
		2(=x) 1=DMA Setup Auto-Activate optimization enabled
		1(=x) 1=Non-zero buffer offset in DMA Setup FIS enabled
		0(=0) Reserved
80	01FCH	Major version number
		ATA-2.3 and ATA/ATAPI-4, 5, 6, 7, 8
81	0028H	Minor version number—ATA8-ACS revision 6 --
82	746BH	Command set supported
		15 (=0) Reserved
		14 (=1) 1=NOP command supported
		13 (=1) 1=READ BUFFER command supported
		12 (=1) 1=WRITE BUFFER command supported
		11 (=0) Reserved
		10 (=1) 1=Host Protected Area Feature Set supported
		9 (=0) 1=DEVICE RESET command supported
		8 (=0) 1=SERVICE interrupt supported
		7 (=0) 1=release interrupt supported
		6 (=1) 1=look-ahead supported
		5 (=1) 1=write cache supported
		4 (=0) 1=supports PACKET Command Feature Set
		3 (=1) 1=supports Power Management Feature Set
		2 (=0) 1=supports Removable Media Feature Set
		1 (=1) 1=supports Security Feature Set
		0 (=1) 1=supports S.M.A.R.T Feature Set

Note.1 The "*" mark in 'Content' field indicates the use of those parameters that are vendor specific.

Table 60 Identify device information --- Continued ---

Word	Content	Description
83	7D29H	Command set supported
		15 (=0) Always
		14 (=1) Always
		13 (=1) 1=FLUSH CACHE EXT command supported
		12 (=1) 1=FLUSH CACHE command supported
		11 (=1) 1=Device Configuration Overlay command supported
		10 (=1) 1=48-bit Address feature set supported
		9 (=0) Reserved.
		8 (=1) 1=SET MAX security extension supported
		7 (=0) Reserved
		6 (=0) 1=SET FEATURES subcommand required to spin-up
		5 (=1) 1=Power-Up In Standby feature set supported
		4 (=0) 1=Removable Media Status Notification Feature Set supported
		3 (=1) 1=Advanced Power Management Feature Set supported
		2 (=0) 1=CFA Feature Set supported
		1 (=0) 1=READ/WRITE DMA QUEUED supported
		0 (=1) Download Microcode Command Supported
84	6163H	Command set/feature supported extension
		15 (=0) Always
		14 (=1) Always
		13 (=1) 1=IDLE IMMEDIATE with UNLOAD FEATURE supported
		12- 9 (=0) Reserved
		8 (=1) 1=64-bit World wide name supported
		7 (=0) 1=WRITE DMA QUEUED FUA EXT command supported
		6 (=1) 1=WRITE DMA FUA EXT and WRITE MULTIPLE FUA EXT commands supported
		5 (=1) 1=General Purpose Logging feature set supported
		4- 2 (=0) Reserved
		1 (=1) 1=SMART self-test supported
		0 (=1) 1=SMART error logging supported

Note.1 The "*" mark in 'Content' field indicates the use of those parameters that are vendor specific.

Table 61 Identify device information --- Continued ---

Word	Content	Description
85	74xxH	Command set/feature enabled
		15 (=0) Obsolete
		14 (=1) 1=NOP command supported
		13 (=1) 1=READ BUFFER command supported
		12 (=1) 1=WRITE BUFFER command supported
		11 (=0) Reserved
		10 (=1) 1=Host Protected Area Feature Set supported
		9 (=0) 1=DEVICE RESET command supported
		8 (=0) 1=SERVICE interrupt enabled
		7 (=0) 1=release interrupt enabled
		6 (=x) 1=look-ahead enabled
		5 (=x) 1=write cache enabled
		4 (=0) 1=supports PACKET Command Feature Set
		3 (=1) 1=supports Power Management Feature Set
		2 (=0) 1=supports Removable Media Feature Set
		1 (=x) 1=Security Feature Set enabled
		0 (=x) 1=S.M.A.R.T Feature Set enabled
86	BxxxH	Command set/feature enabled
		15 (=1) 1=Words 120:119 are valid
	*	14 (=0) Reserved
		13 (=1) 1=FLUSH CACHE EXT command supported
		12 (=1) 1= FLUSH CACHE command supported
		11 (=x) 1=Device Configuration Overlay supported
	*	10 (=1) 1= 48-bit Address feature set supported
		9 (=0) Reserved
		8 (=x) 1=SET MAX security extension enabled
		7 (=0) Reserved
		6 (=0) 1=SET FEATURES subcommand required to spin-up
		5 (=x) 1=Power-Up In Standby feature set has been enabled via the SET FEATURES command
		4 (=0) 1=Removable Media Status Notification Feature Set enabled
		3 (=x) 1=Advanced Power Management Feature Set enabled
		2 (=0) 1=CFA Feature Set supported
		1 (=0) 1=READ/WRITE DMA QUEUED command supported
		0 (=1) 1=DOWNLOAD MICROCODE command supported

Note.1 The "*" mark in 'Content' field indicates the use of those parameters that are vendor specific.

Table 62 Identify device information --- Continued ---

Word	Content	Description
87	6163H	Command set/feature enabled
		15 (=0) Always
		14 (=1) Always
		13 (=1) 1=IDLE IMMEDIATE with UNLOAD FEATURE supported
		12- 9 (=0) Reserved
		8 (=1) 1=64 bit World wide name supported
		7 (=0) 1=WRITE DMA QUEUED FUA EXT command supported
		6 (=1) 1=WRITE DMA FUA EXT and WRITE MULTIPLE FUA EXT command supported
		5 (=1) 1=General Purpose Logging feature set supported
		4- 2 (=0) Reserved
		1 (=1) 1=SMART self-test supported
		0 (=1) 1=SMART error logging supported
88	xx7FH	Ultra DMA Transfer mode (mode 6 supported)
		15 (=0) Reserved
		14 (=x) 1=UltraDMA mode 6 is selected
		13 (=x) 1=UltraDMA mode 5 is selected
		12 (=x) 1=UltraDMA mode 4 is selected
		11 (=x) 1=UltraDMA mode 3 is selected
		10 (=x) 1=UltraDMA mode 2 is selected
		9 (=x) 1=UltraDMA mode 1 is selected
		8 (=x) 1=UltraDMA mode 0 is selected
		7 (=0) Reserved
		6 (=1) 1=UltraDMA mode 6 is supported
		5 (=1) 1=UltraDMA mode 5 is supported
		4 (=1) 1=UltraDMA mode 4 is supported
		3 (=1) 1=UltraDMA mode 3 is supported
		2 (=1) 1=UltraDMA mode 2 is supported
		1 (=1) 1=UltraDMA mode 1 is supported
		0 (=1) 1=UltraDMA mode 0 is supported

Note.1 The "*" mark in 'Content' field indicates the use of those parameters that are vendor specific.

Table 63 Identify device information --- Continued ---

Word	Content	Description
89	xxxxH	Time required for security erase unit completion Time= value(xxxxh)*2 [minutes]
90	xxxxH	Time required for Enhanced security erase completion Time= value(xxxxh)*2 [minutes]
91	40xxH	Current Advanced Power Management level
		15- 8 (=40h) Reserved
		7- 0 (=xxh) Current Advanced Power Management level set by Set Features Command (01h to FEh)
92	xxxxH	Current Master Password Revision Codes
93	0000H	Reserved
94	0000H	Reserved
95	0000H	Stream Minimum Request Size
96	0000H	Streaming Transfer Time - DMA
97	0000H	Streaming Access Latency - DMA and PIO
98-99	0000H	Streaming Performance Granularity
100-103	Note.2	Maximum user LBA address for 48-bit Address feature set
104	0000H	Streaming Transfer Time - PIO
105	0000H	Reserved
106	6003H	Physical sector size/logical sector size
107	826CH	Inter seek delay time (1.5tt + 2.5tl)
108-111	XXXX	World Wide Name
112-116	0000H	Reserved
117-118	0000H	Logical Sector Size
119	401CH	Supported Setting
		15 (=0) Always
		14 (=1) Always
		13-6 (=0) Reserved
		5 (=0) 1=Free-fall Control feature set is supported
		4 (=1) 1=Download Microcode with mode 3 is supported
		3 (=1) 1=Read and Write DMA Ext GPL is supported
		2 (=1) 1=WRITE UNCORRECTABLE is supported
		1 (=0) 1=Write Read Verify feature set is supported
		0 (=0) Reserved
120	401CH	Enabled Setting
		15 (=0) Always
		14 (=1) Always
		13-6 (=0) Reserved
		5 (=0) 1=Free-fall Control feature set is enabled
		4 (=1) 1=Download Microcode with mode 3 is supported
		3 (=1) 1=Read and Write DMA Ext GPL is supported
		2 (=1) 1=WRITE UNCORRECTABLE is supported
		1 (=0) 1=Write Read Verify feature set is enabled
		0 (=0) Reserved
121-126	0000H	Reserved
127	0000H	Removable Media Status Notification feature set

Note.1 The "*" mark in 'Content' field indicates the use of those parameters that are vendor specific.

Table 64 Identify device information --- Continued ---

Word	Content		Description
128	0xxxH		Security status. Bit assignments
			15-9 (=0) Reserved
			8 (=x) Security Level 1= Maximum, 0= High
			7-6 (=0) Reserved
			5 (=1) 1=Enhanced security erase supported
			4 (=x) 1=Security count expired
			3 (=x) 1=Security Frozen
			2 (=x) 1=Security locked
			1 (=x) 1=Security enabled
			0 (=1) 1=Security supported
129	000xH	*	Current Set Feature Option. Bit assignments
			15-4(=0) Reserved
			3(=x) 1=Auto reassign enabled
			2(=x) Reserved
			1(=x) 1=Read Look-ahead enabled
			0(=x) 1=Write Cache enabled
130	xxxxH	*	Reserved
131	000xH	*	Initial Power Mode Selection. Bit assignments
			15-1(=0) Reserved
			0(=x) Initial Power Mode 1= Standby, 0= Idle
132-205	xxxxH	*	Reserved
206	003DH		SCT Command Transport
			15- 6(=0) Reserved
			5(=1) 1=SCT Data Tables supported
			4(=1) 1=SCT Features Control supported
			3(=1) 1=SCT Error Recovery Control supported
			2(=1) 1=SCT Write Same supported
			1(=0) 1=SCT Long Sector Access supported
			0(=1) 1=SCT Command Transport supported
207 - 208	xxxxH	*	Reserved
209	4000H		Alignment of logical blocks within a physical block
210 - 216	xxxxH	*	Reserved
217	1518H		Media Rotation Rate
218 - 221	xxxxH	*	Reserved
222	101FH		Transport Major Revision Number
			15- 12 Transport Type 0=Parallel, 1=Serial, 2-15=Reserved
			11- 5(=0) Reserved
			4(=1) 1=SATA 2.6
			3(=1) 1=SATA 2.5
			2(=1) 1=SATA II: Extensions
			1(=1) 1=SATA 1.0a
			0(=1) 1=ATA8-AST
223	0021H		Transport Minor Revision Number - ATA8-AST Revision 0b
224 - 233	xxxxH	*	Reserved
234	0001H		Minimum number of data blocks per Download Microcode for mode 3
235	03E0H		Maximum number of data blocks per Download Microcode for mode 3
236 - 254	xxxxH	*	Reserved
255	xxA5H		Integrity word
			15-8 (=xxh) Checksum
			7-0 (=A5h) Signature

Note.1 The "*" mark in 'Content' field indicates the use of those parameters that are vendor specific.

Table 65 Identify device information --- Continued ---

Model Number in ASCII	HGST HTE545050A7E680	HGST HTE545032A7E680
Number of cylinders	3FFFh	3FFFh
Number of heads	10h	10h
Total number of user addressable sectors (word 60-61)	FFFFFFFFh	FFFFFFFFh
Maximum user LBA address for 48-bit Address feature set (word 100-103)	3A386030h	2542EAB0h

Table 66 Number of cylinders/heads/sectors by models for HTE5450XXA7E680

14.10 Idle (E3h/97h)

Command Block Output Registers								Command Block Input Registers									
Register	7	6	5	4	3	2	1	0	Register	7	6	5	4	3	2	1	0
Data	-	-	-	-	-	-	-	-	Data	-	-	-	-	-	-	-	-
Feature	-	-	-	-	-	-	-	-	Error	...See Below...							
Sector Count	V	V	V	V	V	V	V	V	Sector Count	-	-	-	-	-	-	-	-
LBA Low	-	-	-	-	-	-	-	-	LBA Low	-	-	-	-	-	-	-	-
LBA Mid	-	-	-	-	-	-	-	-	LBA Mid	-	-	-	-	-	-	-	-
LBA High	-	-	-	-	-	-	-	-	LBA High	-	-	-	-	-	-	-	-
Device	-	-	-	-	-	-	-	-	Device	-	-	-	-	-	-	-	-
Command	1	1	1	0	0	0	1	1	Status	...See Below...							

Error Register								Status Register							
7	6	5	4	3	2	1	0	7	6	5	4	3	2	1	0
CRC	UNC	0	IDN	0	ABT	T0N	AMN	BSY	RDY	DF	DSC	DRQ	COR	IDX	ERR
0	0	0	0	0	V	0	0	0	V	0	V	-	0	0	V

Table 67 Idle Command (E3h/97h)

When the power save mode is Standby mode, the Idle command causes the device to enter performance Idle mode immediately, and set auto power down timeout parameter(standby timer). And then the timer starts counting down. When the device's power save mode is already any idle mode, the device keep that mode.

When the Idle mode is entered, the device is spun up to operating speed. If the device is already spinning, the spin up sequence is not executed.

During Idle mode the device is spinning and ready to respond to host commands immediately.

Output Parameters To The Device

Sector Count Timeout Parameter. If zero, then the automatic power down sequence is disabled. If non-zero, then the automatic power down sequence is enabled, and the timeout interval is shown below:

Value	Timeout
-----	-----
0	Timer disabled
1-240	Value * 5
241-251	(Value-240) * 30 minutes
252	21 minutes
253	8 hours
254	Reserved
255	21 minutes 15 seconds

When the automatic power down sequence is enabled, the drive will enter Standby mode automatically if the timeout interval expires with no drive access from the host. The timeout interval will be reinitialized if there is a drive access before the timeout interval expires.

14.11 Idle Immediate (E1h/95h)

Command Block Output Registers								Command Block Input Registers									
Register	7	6	5	4	3	2	1	0	Register	7	6	5	4	3	2	1	0
Data	-	-	-	-	-	-	-	-	Data	-	-	-	-	-	-	-	-
Feature	-	-	-	-	-	-	-	-	Error	...See Below...							
Sector Count	-	-	-	-	-	-	-	-	Sector Count	-	-	-	-	-	-	-	-
LBA Low	-	-	-	-	-	-	-	-	LBA Low	-	-	-	-	-	-	-	-
LBA Mid	-	-	-	-	-	-	-	-	LBA Mid	-	-	-	-	-	-	-	-
LBA High	-	-	-	-	-	-	-	-	LBA High	-	-	-	-	-	-	-	-
Device	-	-	-	-	-	-	-	-	Device	-	-	-	-	-	-	-	-
Command	1	1	1	0	0	0	0	1	Status	...See Below...							

Unload Feature

Command Block Output Registers								Command Block Input Registers									
Register	7	6	5	4	3	2	1	0	Register	7	6	5	4	3	2	1	0
Data	-	-	-	-	-	-	-	-	Data	-	-	-	-	-	-	-	-
Feature	0	1	0	0	0	1	0	0	Error	...See Below...							
Sector Count	0	0	0	0	0	0	0	0	Sector Count	-	-	-	-	-	-	-	-
LBA Low	0	1	0	0	1	1	0	0	LBA Low	1	1	0	0	0	1	0	0
LBA Mid	0	1	0	0	1	1	1	0	LBA Mid	-	-	-	-	-	-	-	-
LBA High	0	1	0	1	0	1	0	1	LBA High	-	-	-	-	-	-	-	-
Device	-	-	-	D	-	-	-	-	Device	-	-	-	-	-	-	-	-
Command	1	1	1	0	0	0	0	1	Status	...See Below...							

Error Register								Status Register							
7	6	5	4	3	2	1	0	7	6	5	4	3	2	1	0
CRC	UNC	0	IDN	0	ABT	T0N	AMN	BSY	RDY	DF	DSC	DRQ	COR	IDX	ERR
0	0	0	0	0	V	0	0	0	V	0	V	-	0	0	V

Table 68 Idle Immediate Command (E1h/95h)

The Idle Immediate command causes the device to enter performance Idle mode.

The device is spun up to operating speed. If the device is already spinning, the spin up sequence is not executed.

During Idle mode the device is spinning and ready to respond to host commands immediately.

The Idle Immediate command will not affect the auto power down timeout parameter.

Unload Feature:

The UNLOAD FEATURE of the IDLE IMMEDIATE command allows the host to immediately unload the heads. The device stops read look-ahead if it is in process. If the device is performing a write operation, the device suspends writing cached data onto the media as soon as possible. The data in the write cache is retained, and the device resumes writing the cached data onto the media after receiving a Software Reset, a Hardware Reset, or any new command except IDLE IMMEDIATE with UNLOAD FEATURE.

14.12 Initialize Device Parameters (91h)

Command Block Output Registers								Command Block Input Registers									
Register	7	6	5	4	3	2	1	0	Register	7	6	5	4	3	2	1	0
Data	-	-	-	-	-	-	-	-	Data	-	-	-	-	-	-	-	-
Feature	-	-	-	-	-	-	-	-	Error	...See Below...							
Sector Count	V	V	V	V	V	V	V	V	Sector Count	-	-	-	-	-	-	-	-
LBA Low	-	-	-	-	-	-	-	-	LBA Low	-	-	-	-	-	-	-	-
LBA Mid	-	-	-	-	-	-	-	-	LBA Mid	-	-	-	-	-	-	-	-
LBA High	-	-	-	-	-	-	-	-	LBA High	-	-	-	-	-	-	-	-
Device	-	-	-	-	H	H	H	H	Device	-	-	-	-	-	-	-	-
Command	1	0	0	1	0	0	0	1	Status	...See Below...							

Error Register								Status Register							
7	6	5	4	3	2	1	0	7	6	5	4	3	2	1	0
CRC	UNC	0	IDN	0	ABT	T0N	AMN	BSY	RDY	DF	DSC	DRQ	COR	IDX	ERR
0	0	0	0	0	V	0	0	0	0	0	-	-	0	0	V

Table 69 Initialize Device Parameters Command (91h)

The Initialize Device Parameters command enables the host to set the number of sectors per track and the number of heads minus 1, per cylinder. Words 54-58 in Identify Device Information reflects these parameters.

The parameters remain in effect until the following events:

- Another Initialize Device Parameters command is received.
- The device is powered off.

Output Parameters To The Device

Sector Count The number of sectors per track. 0 does not mean there are 256 sectors per track, but there is no sector per track.

H The number of heads minus 1 per cylinder. The minimum is 0 and the maximum is 15.

14.13 Read Buffer (E4h)

Command Block Output Registers								Command Block Input Registers									
Register	7	6	5	4	3	2	1	0	Register	7	6	5	4	3	2	1	0
Data	-	-	-	-	-	-	-	-	Data	-	-	-	-	-	-	-	-
Feature	-	-	-	-	-	-	-	-	Error	...See Below...							
Sector Count	-	-	-	-	-	-	-	-	Sector Count	-	-	-	-	-	-	-	-
LBA Low	-	-	-	-	-	-	-	-	LBA Low	-	-	-	-	-	-	-	-
LBA Mid	-	-	-	-	-	-	-	-	LBA Mid	-	-	-	-	-	-	-	-
LBA High	-	-	-	-	-	-	-	-	LBA High	-	-	-	-	-	-	-	-
Device	-	-	-	-	-	-	-	-	Device	-	-	-	-	-	-	-	-
Command	1	1	1	0	0	1	0	0	Status	...See Below...							

Error Register								Status Register							
7	6	5	4	3	2	1	0	7	6	5	4	3	2	1	0
CRC	UNC	0	IDN	0	ABT	T0N	AMN	BSY	RDY	DF	DSC	DRQ	COR	IDX	ERR
0	0	0	0	0	V	0	0	0	V	0	-	-	0	0	V

Table 70 Read Buffer Command (E4h)

The Read Buffer command transfers a sector of data from the sector buffer of device to the host.

The sector is transferred through the Data Register 16 bits at a time.

The sector transferred will be from the same part of the buffer written to by the last Write Buffer command. The contents of the sector may be different if any reads or writes have occurred since the Write Buffer command was issued.

14.14 Read DMA(C8h/C9h)

Command Block Output Registers								Command Block Input Registers									
Register	7	6	5	4	3	2	1	0	Register	7	6	5	4	3	2	1	0
Data	-	-	-	-	-	-	-	-	Data	-	-	-	-	-	-	-	-
Feature	-	-	-	-	-	-	-	-	Error	...See Below...							
Sector Count	V	V	V	V	V	V	V	V	Sector Count	V	V	V	V	V	V	V	V
LBA Low	V	V	V	V	V	V	V	V	LBA Low	V	V	V	V	V	V	V	V
LBA Mid	V	V	V	V	V	V	V	V	LBA Mid	V	V	V	V	V	V	V	V
LBA High	V	V	V	V	V	V	V	V	LBA High	V	V	V	V	V	V	V	V
Device	-	L	-	-	H	H	H	H	Device	-	-	-	-	H	H	H	H
Command	1	1	0	0	1	0	0	R	Status	...See Below...							

Error Register								Status Register							
7	6	5	4	3	2	1	0	7	6	5	4	3	2	1	0
CRC	UNC	0	IDN	0	ABT	T0N	AMN	BSY	RDY	DF	DSC	DRQ	COR	IDX	ERR
V	V	0	V	0	V	0	0	0	V	0	V	-	0	0	V

Table 71 Read DMA Command (C8h/C9h)

The Read DMA command reads one or more sectors of data from disk media, then transfers the data from the device to the host.

The sectors are transferred through the Data Register 16 bits at a time.

The host initializes a slave-DMA channel prior to issuing the command. The data transfers are qualified by DMARQ and are performed by the slave-DMA channel. The device issues only one interrupt per command to indicate that data transfer has terminated and status is available.

If an uncorrectable error occurs, the read will be terminated at the failing sector.

Output Parameters To The Device

- Sector Count** The number of continuous sectors to be transferred. If zero is specified, then 256 sectors will be transferred.
- LBA Low** The sector number of the first sector to be transferred. (L=0)
In LBA mode, this register specifies LBA address bits 0 - 7 to be transferred. (L=1)
- LBA High/Mid** The cylinder number of the first sector to be transferred. (L=0)
In LBA mode, this register specifies LBA address bits 8 - 15 (Mid) 16 - 23 (High) to be transferred. (L=1)
- H** The head number of the first sector to be transferred. (L=0)
In LBA mode, this register specifies LBA bits 24-27 to be transferred. (L=1)
- R** The retry bit, but this bit is ignored.

Input Parameters From The Device

- Sector Count** The number of requested sectors not transferred. This will be zero, unless an unrecoverable error occurs.
- LBA Low** The sector number of the last transferred sector. (L=0)
In LBA mode, this register contains current LBA bits 0 - 7. (L=1)
- LBA High/Mid** The cylinder number of the last transferred sector. (L=0)
In LBA mode, this register contains current LBA bits 8 - 15 (Mid), 16 - 23 (High). (L=1)
- H** The head number of the sector to be transferred. (L=0)
In LBA mode, this register contains current LBA bits 24 - 27. (L=1)

14.15 Read DMA Ext (25h)

Command Block Output Registers									Command Block Input Registers								
Register	7	6	5	4	3	2	1	0	Register	7	6	5	4	3	2	1	0
Data Low	-	-	-	-	-	-	-	-	Data Low	-	-	-	-	-	-	-	-
Data High	-	-	-	-	-	-	-	-	Data High	-	-	-	-	-	-	-	-
Feature	Current	-	-	-	-	-	-	-	Error	...See Below...							
	Previous	-	-	-	-	-	-	-									
Sector Count	Current	V	V	V	V	V	V	V	Sector Count	HOB=0	-	-	-	-	-	-	-
	Previous	V	V	V	V	V	V	V	HOB=1	-	-	-	-	-	-	-	-
LBA Low	Current	V	V	V	V	V	V	V	LBA Low	HOB=0	V	V	V	V	V	V	V
	Previous	V	V	V	V	V	V	V	HOB=1	V	V	V	V	V	V	V	V
LBA Mid	Current	V	V	V	V	V	V	V	LBA Mid	HOB=0	V	V	V	V	V	V	V
	Previous	V	V	V	V	V	V	V	HOB=1	V	V	V	V	V	V	V	V
LBA High	Current	V	V	V	V	V	V	V	LBA High	HOB=0	V	V	V	V	V	V	V
	Previous	V	V	V	V	V	V	V	HOB=1	V	V	V	V	V	V	V	V
Device	-	1	-	-	-	-	-	-	Device	-	-	-	-	-	-	-	-
Command	0	0	1	0	0	1	0	1	Status	...See Below...							

Error Register								Status Register							
7	6	5	4	3	2	1	0	7	6	5	4	3	2	1	0
CRC	UNC	0	IDN	0	ABT	TON	AMN	BSY	RDY	DF	DSC	DRQ	COR	IDX	ERR
V	V	0	V	0	V	0	0	0	V	0	V	-	0	0	V

Table 72 Read DMA Ext Command (25h)

The Read DMA Ext command reads one or more sectors of data from disk media, then transfers the data from the device to the host.

The sectors are transferred through the Data Register 16 bits at a time.

The host initializes a slave-DMA channel prior to issuing the command. The data transfers are qualified by DMARQ and are performed by the slave-DMA channel. The device issues only one interrupt per command to indicate that data transfer has terminated and status is available.

If an uncorrectable error occurs, the read will be terminated at the failing sector.

Output Parameters To The Device

Sector Count Current The number of sectors to be transferred low order, bits (7:0).

Sector Count Previous The number of sectors to be transferred high order, bits (15:8). If 0000h in the Sector Count register is specified, then 65,536 sectors will be transferred.

LBA Low Current LBA (7:0)

LBA Low Previous LBA (31:24)

LBA Mid Current LBA (15:8)

LBA Mid Previous LBA (39:32)

LBA High Current LBA (23:16)

LBA High Previous LBA (47:40)

Input Parameters From The Device

LBA Low (HOB=0) LBA (7:0) of the address of the first unrecoverable error.

LBA Low (HOB=1) LBA (31:24) of the address of the first unrecoverable error.

LBA Mid (HOB=0) LBA (15:8) of the address of the first unrecoverable error.

LBA Mid (HOB=1) LBA (39:32) of the address of the first unrecoverable error.

LBA High (HOB=0) LBA (23:16) of the address of the first unrecoverable error.

LBA High (HOB=1) LBA (47:40) of the address of the first unrecoverable error.

14.16 Read FPDMA Queued (60h)

Command Block Output Registers									Command Block Input Registers										
Register		7	6	5	4	3	2	1	0	Register		7	6	5	4	3	2	1	0
Data Low		-	-	-	-	-	-	-	-	Data Low		-	-	-	-	-	-	-	-
Data High		-	-	-	-	-	-	-	-	Data High		-	-	-	-	-	-	-	-
Feature	Current	V	V	V	V	V	V	V	V	Error		...See Below...							
	Previous	V	V	V	V	V	V	V	V										
Sector Count	Current	T	T	T	T	T	-	-	-	Sector Count	HOB=0	-	-	-	-	-	-	-	-
	Previous	P	-	-	-	-	-	-	-		HOB=1	-	-	-	-	-	-	-	-
LBA Low	Current	V	V	V	V	V	V	V	V	LBA Low	HOB=0	V	V	V	V	V	V	V	V
	Previous	V	V	V	V	V	V	V	V		HOB=1	V	V	V	V	V	V	V	V
LBA Mid	Current	V	V	V	V	V	V	V	V	LBA Mid	HOB=0	V	V	V	V	V	V	V	V
	Previous	V	V	V	V	V	V	V	V		HOB=1	V	V	V	V	V	V	V	V
LBA High	Current	V	V	V	V	V	V	V	V	LBA High	HOB=0	V	V	V	V	V	V	V	V
	Previous	V	V	V	V	V	V	V	V		HOB=1	V	V	V	V	V	V	V	V
Device		F	1	-	-	-	-	-	-	Device		-	-	-	-	-	-	-	-
Command		0	1	1	0	0	0	0	0	Status		...See Below...							

Error Register								Status Register							
7	6	5	4	3	2	1	0	7	6	5	4	3	2	1	0
CRC	UNC	0	IDN	0	ABT	TON	AMN	BSY	RDY	DF	DSC	DRQ	COR	IDX	ERR
V	V	0	V	0	V	0	0	0	V	0	V	-	0	0	V

Table 73 Read FPDMA Queued Command (60h)

The Read FPDMA Queued command reads one or more sectors of data from disk media, then transfers the data from the device to the host.

If an uncorrectable error occurs, the read will be terminated at the failing sector.

Output Parameters To The Device

Feature Current	The number of sectors to be transferred low order, bits (7:0)
Feature Previous	The number of sectors to be transferred high order, bits (15:8)
T	TAG value. It shall be assigned to be different from all other queued commands. The value shall not exceed the maximum queue depth specified by the Word 75 of the Identify Device information.
LBA Low Current	LBA (7:0)
LBA Low Previous	LBA (31:24)
LBA Mid Current	LBA (15:8)
LBA Mid Previous	LBA (39:32)
LBA High Current	LBA (23:16)
LBA High Previous	LBA (47:40)
F	FUA bit. When the FUA bit is set to 1, the requested data is always retrieved from the media regardless of whether the data are held in the sector buffer or not. When the FUA bit is set to 0, the data may be retrieved from the media or from the cached data left by previously processed Read or Write commands.
P	Priority bit. When the Priority bit is set to 1, the device attempts to provide better quality of service for the command than normal priority commands.

Input Parameters From The Device

LBA Low (HOB=0)	LBA (7:0) of the address of the first unrecoverable error.
LBA Low (HOB=1)	LBA (31:24) of the address of the first unrecoverable error.
LBA Mid (HOB=0)	LBA (15:8) of the address of the first unrecoverable error.
LBA Mid (HOB=1)	LBA (39:32) of the address of the first unrecoverable error.
LBA High (HOB=0)	LBA (23:16) of the address of the first unrecoverable error.
LBA High (HOB=1)	LBA (47:40) of the address of the first unrecoverable error.

14.17 Read Log Ext(2Fh)

Command Block Output Registers									Command Block Input Registers								
Register	7	6	5	4	3	2	1	0	Register	7	6	5	4	3	2	1	0
Data Low	-	-	-	-	-	-	-	-	Data Low	-	-	-	-	-	-	-	-
Data High	-	-	-	-	-	-	-	-	Data High	-	-	-	-	-	-	-	-
Feature	Current	-	-	-	-	-	-	R-	Error	...See Below...							
	Previous	-	-	-	-	-	-	-									
Sector Count	Current	V	V	V	V	V	V	V	Sector Count	HOB=0	-	-	-	-	-	-	-
	Previous	V	V	V	V	V	V	V	HOB=1	-	-	-	-	-	-	-	-
LBA Low	Current	V	V	V	V	V	V	V	LBA Low	HOB=0	-	-	-	-	-	-	-
	Previous	-	-	-	-	-	-	-	HOB=1	-	-	-	-	-	-	-	-
LBA Mid	Current	V	V	V	V	V	V	V	LBA Mid	HOB=0	-	-	-	-	-	-	-
	Previous	V	V	V	V	V	V	V	HOB=1	-	-	-	-	-	-	-	-
LBA High	Current	-	-	-	-	-	-	-	LBA High	HOB=0	-	-	-	-	-	-	-
	Previous	-	-	-	-	-	-	-	HOB=1	-	-	-	-	-	-	-	-
Device	-	-	-	-	-	-	-	-	Device	-	-	-	-	-	-	-	-
Command	0	0	1	0	1	1	1	1	Status	...See Below...							

Error Register								Status Register							
7	6	5	4	3	2	1	0	7	6	5	4	3	2	1	0
CRC	UNC	0	IDN	0	ABT	TON	AMN	BSY	RDY	DF	DSC	DRQ	COR	IDX	ERR
V	V	0	V	0	V	0	0	0	V	0	V	-	0	0	V

Table 74 Read Log Ext Command (2Fh)

This command returns the specified log to the host. The device shall interrupt for each DRQ block transferred.

Output Parameters To The Device

- R** Phy Event Counter Reset bit. When Log address is 11h (Phy Event Counter) and this bit is set to 1, all Phy Event Counter values are reset to 0 after sending the current counter values.
- Sector Count Current** The number of sectors to be read from the specified log low order, bits (7:0). The log transferred by the drive shall start at the sector in the specified log at the specified offset, regardless of the sector count requested.
- Sector Count Previous** The number of sectors to be read from the specified log high orders, bits (15:8).
- LBA Low Current** The log to be returned as described in the following table.
- LBA Mid Current** The first sector of the log to be read low order, bits (7:0).
- LBA Mid Previous** The first sector of the log to be read high order, bits (15:8).

Log address	Content	Feature set	Type
00h	Log directory	N/A	Read Only
03h	Extended Comprehensive SMART error log	SMART error logging	Read Only
07h	Extended SMART self-test log	SMART self-test	Read Only
10h	Command Error	Native Command Queuing	Read Only
11h	Phy Event Counter	Phy Event Counter	Read Only
80h-9Fh	Host vendor specific	SMART	Read/Write

Table 75 Log address definition

The Extended SMART self-test log sector shall support 48-bit and 28-bit addressing. All 28-bit entries contained in the SMART self-test log sector shall also be included in the Comprehensive SMART self-test log sector with the 48-bit entries.

If the feature set associated with the log specified in the Sector Number register is not supported or enabled, or if the values in the Sector Count, Sector Number or Cylinder Low registers are invalid, the device shall return command aborted.

14.17.1 General purpose Log Directory

The following table defines the 512 bytes that make up the General Purpose Log Directory.

Description	Bytes	Offset
General Purpose Logging Version	2	00h
Number of sectors in the log at log address 01h (7:0)	1	02h
Number of sectors in the log at log address 01h (15:8)	1	03h
Number of sectors in the log at log address 02h (7:0)	1	04h
Number of sectors in the log at log address 02h (15:8)	1	05h
...		
Number of sectors in the log at log address 80h (7:0)	1	100h
Number of sectors in the log at log address 80h (15:8)	1	101h
...		
Number of sectors in the log at log address FFh (7:0)	1	1FEh
Number of sectors in the log at log address FFh (15:8)	1	1FFh
	512	

Table 76 General purpose Log Directory

The value of the General Purpose Logging Version word shall be 0001h. A value of 0000h indicates that there is no General Purpose Log Directory.

The logs at log addresses 80-9Fh shall each be defined as 16 sectors long.

14.17.2 Extended comprehensive SMART error log

The following table defines the format of each of the sectors that comprise the Extended Comprehensive SMART error log. Error log data structure shall not include errors attributed to the receipt of faulty commands such as command codes not implemented by the device or requests with invalid parameters or in valid addresses.

Description	Bytes	Offset
SMART error log version	1	00h
Reserved	1	01h
Error log index (7:0)	1	02h
Error log index (15:8)	1	03h
1 st error log data structure	124	04h
2 nd error log data structure	124	80h
3 rd error log data structure	124	FCh
4 th error log data structure	124	178h
Device error count	2	1F4h
Reserved	9	1F6h
Data structure checksum	1	1FFh
	512	

Table 77 Extended comprehensive SMART error Log

14.17.2.1 Error Log version

The value of this version shall be 01h.

14.17.2.2 Error log index

This indicates the error log data structure representing the most recent error. If there have been no error log entries, it is cleared to 0. Valid values for the error log index are 0 to 4.

14.17.2.3 Extended Error log data structure

An error log data structure shall be presented for each of the last four errors reported by the device. These error log data structure entries are viewed as a circular buffer. The fifth error shall create an error log structure that

replaces the first error log data structure. The next error after that shall create an error log data structure that replaces the second error log structure, etc.

Unused error log data structures shall be filled with zeros.

Data format of each error log structure is shown below.

Description	Bytes	Offset
1 st command data structure	18	00h
2 nd command data structure	18	12h
3 rd command data structure	18	24h
4 th command data structure	18	36h
5 th command data structure	18	48h
Error data structure	34	5Ah
	124	

Table 78 Extended Error log data structure

Command data structure: Data format of each command data structure is shown below.

Description	Bytes	Offset
Device Control register	1	00h
Features register (7:0) (see Note)	1	01h
Features register (15:8)	1	02h
Sector count register (7:0)	1	03h
Sector count register (15:8)	1	04h
Sector number register (7:0)	1	05h
Sector number register (15:8)	1	06h
Cylinder Low register (7:0)	1	07h
Cylinder Low register (15:8)	1	08h
Cylinder High register (7:0)	1	09h
Cylinder High register (15:8)	1	0Ah
Device register	1	0Bh
Command register	1	0Ch
Reserved	1	0Dh
Timestamp (milliseconds from Power-on)	4	0Eh
	18	

Note: bits (7:0) refer to the most recently written contents of the register. Bits (15:8) refer to the contents of the register prior to the most recent write to the register.

Table 79 Command data structure

Error data structure: Data format of error data structure is shown below.

Description	Bytes	Offset
Reserved	1	00h
Error register	1	01h
Sector count register (7:0) (see Note)	1	02h
Sector count register (15:8) (see Note)	1	03h
Sector number register (7:0)	1	04h
Sector number register (15:8)	1	05h
Cylinder Low register (7:0)	1	06h
Cylinder Low register (15:8)	1	07h
Cylinder High register (7:0)	1	08h
Cylinder High register (15:8)	1	09h
Device register	1	0Ah
Status register	1	0Bh
Extended error data (vendor specific)	19	0Ch
State	1	1Fh
Life timestamp (hours)	2	20h
	34	

Note: bits (7:0) refer to the contents if the register is read with bit 7 of the Device Control register cleared to zero. Bits (15:8) refer to the contents if the register is read with bit 7 of the Device Control register set to one.

Table 80 Error data structure

State shall contain a value indicating the state of the device when the command was issued to the device or the reset occurred as described below.

Value	State
x0h	Unknown
x1h	Sleep
x2h	Standby
x3h	Active/Idle
x4h	SMART Off-line or Self-test
x5h-xAh	Reserved
xBh-xFh	Vendor specific

Note: The value of x is vendor specific.

14.17.2.4 Device error count

This field shall contain the total number of errors attributable to the device that have been reported by the device during the life of the device. This count shall not include errors attributed to the receipt of faulty commands such as commands codes not implemented by the device or requests with invalid parameters or invalid addresses. If the maximum value for this field is reached the count shall remain at the maximum value when additional errors are encountered and logged.

14.17.3 Extended Self-test log sector

The following table defines the format of each of the sectors that comprise the Extended SMART self-test log.

The Extended SMART self-test log sector shall support 48-bit and 28-bit addressing. All 28-bit entries contained in the SMART self-test log, defined in “Self-test log data structure” shall also be included in the Extended SMART self-test log with all 48-bit entries.

Description	Bytes	Offset
Self-test log data structure revision number	1	00h
Reserved	1	01h
Self-test descriptor index (7:0)	1	02h
Self-test descriptor index (15:8)	1	03h
Descriptor entry 1	26	04h
Descriptor entry 2	26	1Eh
...		
Descriptor entry 19	26	1D8h
Vendor specific	2	1F2h
Reserved	11	1F4h
Data structure checksum	1	1FFh
	512	

Table 81 Extended Self-test log data structure

These descriptor entries are viewed as a circular buffer. The nineteenth self-test shall create a descriptor entry that replaces descriptor entry 1. The next self-test after that shall create a descriptor entry that replaces descriptor entry 2, etc. All unused self-test descriptors shall be filled with zeros

14.17.3.1 Self-test log data structure revision number

The value of this revision number shall be 01h.

14.17.3.2 Self-test descriptor index

This indicates the most recent self-test descriptor. If there have been no self-tests, this is set to zero. Valid values for the Self-test descriptor index are 0 to 18.

14.17.3.3 Extended Self-test log descriptor entry

The content of the self-test descriptor entry is shown below.

Description	Bytes	Offset
Self-test number	1	00h
Self-test execution status	1	01h
Power-on life timestamp in hours	2	02h
Self-test failure check point	1	04h
Failing LBA (7:0)	1	05h
Failing LBA (15:8)	1	06h
Failing LBA (23:16)	1	07h
Failing LBA (31:24)	1	08h
Failing LBA (39:32)	1	09h
Failing LBA (47:40)	1	0Ah
Vendor specific	15	0Bh
	26	

Table 82 Extended Self-test log descriptor entry

14.17.4 Command Error

The following table defines the format of the Command Error data structure.

Byte	7	6	5	4	3	2	1	0
0	NQ	Rsv	Rsv	TAG				
1	Reserved							
2	Status							
3	Error							
4	LBA Low							
5	LBA Mid							
6	LBA High							
7	Device							
8	LBA Low Previous							
9	LBA Mid Previous							
10	LBA High Previous							
11	Reserved							
12	Sector Count							
13	Sector Count Previous							
14 – 255	Reserved							
256 – 510	Vendor Unique							
511	Data Structure Checksum							

Table 83 Command Error information

The TAG field (Byte 0 bits 4-0) contains the tag number corresponding to a queued command, if the NQ bit is cleared.

The NQ field (Byte 0 bit 7) indicates whether the error condition was a result of a non-queued or not. If it is cleared, the error information corresponds to a queued command specified by the tag number indicated in the TAG field.

The bytes 1 to 13 correspond to the contents of Shadow Register Block when the error was reported.

The Data Structure Checksum (Byte 511) contains the 2's complement of the sum of the first 511 bytes in the data structure. The sum of all 512 bytes of the data structure will be zero when the checksum is correct.

14.17.5 Phy Event Counter

Phy Event Counters are a feature to obtain more information about Phy level events that occur on the interface. The counter values are not retained across power cycles. The counter values are preserved across COMRESET and software resets.

14.17.5.1 Counter Reset Mechanisms

There are 2 mechanisms by which the host can explicitly cause the Phy counters to be reset. The first mechanism is to issue a BIST Activate FIS to the drive. The second mechanism uses the Read Log Ext command. When the drive receives a Read Log Ext command for log page 11h and bit 0 in Feature register is set to one, the drive returns the current counter values for the command and then resets all Phy event counter values.

14.17.5.2 Counter Identifiers

Each counter begins with a 16-bit identifier. The following table defines the counter value for each identifier.

For all counter descriptions, “transmitted” refers to items sent by the drive to the host and “received” refers to items received by the drive from the host.

Bit 15 of the counter identifier is reserved for future definition.

Bits 14:12 of the counter identifier convey the number of significant bits that counter uses. All counter values consumes a multiple of 16-bits. The valid values for bit 14:12 and the corresponding counter size are:

1h	16-bit counter
2h	32-bit counter
3h	48-bit counter
4h	64-bit counter

Bits 11:0 of the counter identifier are identifiers defined in the following table.

Identifier (Bits 11:0)	Description
000h	No counter value; marks end of counters in the page
001h	Command failed due to ICRC error
002h	R_ERR response for Data FIS
003h	R_ERR response for Device-to-Host Data FIS
004h	R_ERR response for Host-to-Device Data FIS
005h	R_ERR response for non-Data FIS
006h	R_ERR response for Device-to-Host non-Data FIS
007h	R_ERR response for Host-to-Device non-Data FIS
009h	Transfer from drive PhyRdy to drive PhyNRdy
00Ah	Signature D2H register FISes sent due to a COMRESET
00Bh	CRC errors within the FIS (received)
00Dh	Non-CRC errors within the FIS (received)

Table 84 Phy Event Counter Identifier

14.17.5.3 Read Log Ext Log Page 11h

The following table defines the format of the Phy Event counter data structure.

Byte	7	6	5	4	3	2	1	0
0	00h							
1	00h							
2	00h							
3	00h							
4	Counter 0001h Identifier							
5								
6	Counter 0001h Value							
7								
8	Counter 0002h Identifier							
9								
10	Counter 0002h Value							
11								
12	Counter 0003h Identifier							
13								
14	Counter 0003h Value							
15								
16	Counter 0004h Identifier							
17								
18	Counter 0004h Value							
19								
20	Counter 0005h Identifier							
21								
22	Counter 0005h Value							
23								
24	Counter 0006h Identifier							
25								
26	Counter 0006h Value							
27								
28	Counter 0007h Identifier							
29								
30	Counter 0007h Value							
31								
32	Counter 0009h Identifier							
33								
34	Counter 0009 Value							
35								
36	Counter 000Ah Identifier							
37								
38	Counter 000Ah Value							
39								
40	Counter 000Bh Identifier							
41								
42	Counter 000Bh Value							
43								
44	Counter 000Dh Identifier							
45								
46	Counter 000Dh Value							
47								
48	00h							
49	00h							
50 - 510	Reserved (00h)							
511	Data Structure Checksum							

Table 85 Phy Event Counter information

The Data Structure Checksum (Byte 511) contains the 2's complement of the sum of the first 511 bytes in the data structure. The sum of all 512 bytes of the data structure will be zero when the checksum is correct.

14.18 Read Log DMA Ext(47h)

Command Block Output Registers									Command Block Input Registers										
Register		7	6	5	4	3	2	1	0	Register		7	6	5	4	3	2	1	0
Data Low		-	-	-	-	-	-	-	-	Data Low		-	-	-	-	-	-	-	-
Data High		-	-	-	-	-	-	-	-	Data High		-	-	-	-	-	-	-	-
Feature	Current	-	-	-	-	-	-	-	R-	Error		...See Below...							
	Previous	-	-	-	-	-	-	-	-										
Sector Count	Current	V	V	V	V	V	V	V	V	Sector Count	HOB=0	-	-	-	-	-	-	-	-
	Previous	V	V	V	V	V	V	V	V		HOB=1	-	-	-	-	-	-	-	-
LBA Low	Current	V	V	V	V	V	V	V	V	LBA Low	HOB=0	-	-	-	-	-	-	-	-
	Previous	-	-	-	-	-	-	-	-		HOB=1	-	-	-	-	-	-	-	-
LBA Mid	Current	V	V	V	V	V	V	V	V	LBA Mid	HOB=0	-	-	-	-	-	-	-	-
	Previous	V	V	V	V	V	V	V	V		HOB=1	-	-	-	-	-	-	-	-
LBA High	Current	-	-	-	-	-	-	-	-	LBA High	HOB=0	-	-	-	-	-	-	-	-
	Previous	-	-	-	-	-	-	-	-		HOB=1	-	-	-	-	-	-	-	-
Device		-	-	-	-	-	-	-	-	Device		-	-	-	-	-	-	-	-
Command		0	1	0	0	0	1	1	1	Status		...See Below...							

Error Register								Status Register							
7	6	5	4	3	2	1	0	7	6	5	4	3	2	1	0
CRC	UNC	0	IDN	0	ABT	TON	AMN	BSY	RDY	DF	DSC	DRQ	COR	IDX	ERR
V	V	0	V	0	V	0	0	0	V	0	V	-	0	0	V

Table 86 Read Log DMA Ext Command (47h)

The content of this command is the same as Read Log Ext. See 14.17 14.17.

14.19 Read Multiple (C4h)

Command Block Output Registers								Command Block Input Registers									
Register	7	6	5	4	3	2	1	0	Register	7	6	5	4	3	2	1	0
Data	-	-	-	-	-	-	-	-	Data	-	-	-	-	-	-	-	-
Feature	-	-	-	-	-	-	-	-	Error	...See Below...							
Sector Count	V	V	V	V	V	V	V	V	Sector Count	V	V	V	V	V	V	V	V
LBA Low	V	V	V	V	V	V	V	V	LBA Low	V	V	V	V	V	V	V	V
LBA Mid	V	V	V	V	V	V	V	V	LBA Mid	V	V	V	V	V	V	V	V
LBA High	V	V	V	V	V	V	V	V	LBA High	V	V	V	V	V	V	V	V
Device	-	L	-	-	H	H	H	H	Device	-	-	-	-	H	H	H	H
Command	1	1	0	0	0	1	0	0	Status	...See Below...							

Error Register								Status Register							
7	6	5	4	3	2	1	0	7	6	5	4	3	2	1	0
CRC	UNC	0	IDN	0	ABT	T0N	AMN	BSY	RDY	DF	DSC	DRQ	COR	IDX	ERR
0	V	0	V	0	V	0	0	0	V	0	V	-	0	0	V

Table 87 Read Multiple Command (C4h)

The Read Multiple command reads one or more sectors of data from disk media, then transfers the data from the device to the host.

The sectors are transferred through the Data Register 16 bits at a time. Command execution is identical to the Read Sectors command except that an interrupt is generated for each block (as defined by the Set Multiple command) instead of for each sector.

Output Parameters To The Device

Sector Count The number of continuous sectors to be transferred. If zero is specified, then 256 sectors will be transferred.

LBA Low The sector number of the first sector to be transferred. (L=0)
In LBA mode, this register contains LBA bits 0 - 7. (L=1)

LBA High/Mid The cylinder number of the first sector to be transferred. (L=0)
In LBA mode, this register contains LBA bits 8 - 15 (Mid), 16 - 23 (High). (L=1)

H The head number of the first sector to be transferred. (L=0)
In LBA mode, this register contains LBA bits 24 - 27. (L=1)

Input Parameters From The Device

Sector Count The number of requested sectors not transferred. This will be zero, unless an unrecoverable error occurs.

LBA Low The sector number of the last transferred sector. (L=0)
In LBA mode, this register contains current LBA bits 0 - 7. (L=1)

LBA High/Mid The cylinder number of the last transferred sector. (L=0)
In LBA mode, this register contains current LBA bits 8-15 (Mid), 16-23 (High). (L=1)

H The head number of the last transferred sector. (L=0)
LBA mode, this register contains current LBA bits 24 - 27. (L=1)

14.20 Read Multiple Ext (29h)

Command Block Output Registers								Command Block Input Registers											
Register		7	6	5	4	3	2	1	0	Register		7	6	5	4	3	2	1	0
Data Low		-	-	-	-	-	-	-	-	Data Low		-	-	-	-	-	-	-	-
Data High		-	-	-	-	-	-	-	-	Data High		-	-	-	-	-	-	-	-
Feature	Current	-	-	-	-	-	-	-	-	Error		...See Below...							
	Previous	-	-	-	-	-	-	-	-										
Sector Count	Current	V	V	V	V	V	V	V	V	Sector Count	HOB=0	-	-	-	-	-	-	-	-
	Previous	V	V	V	V	V	V	V	V		HOB=1	-	-	-	-	-	-	-	-
LBA Low	Current	V	V	V	V	V	V	V	V	LBA Low	HOB=0	V	V	V	V	V	V	V	V
	Previous	V	V	V	V	V	V	V	V		HOB=1	V	V	V	V	V	V	V	V
LBA Mid	Current	V	V	V	V	V	V	V	V	LBA Mid	HOB=0	V	V	V	V	V	V	V	V
	Previous	V	V	V	V	V	V	V	V		HOB=1	V	V	V	V	V	V	V	V
LBA High	Current	V	V	V	V	V	V	V	V	LBA High	HOB=0	V	V	V	V	V	V	V	V
	Previous	V	V	V	V	V	V	V	V		HOB=1	V	V	V	V	V	V	V	V
Device		-	1	-	-	-	-	-	-	Device		-	-	-	-	-	-	-	-
Command		0	0	1	0	1	0	0	1	Status		...See Below...							

Error Register								Status Register							
7	6	5	4	3	2	1	0	7	6	5	4	3	2	1	0
CRC	UNC	0	IDN	0	ABT	TON	AMN	BSY	RDY	DF	DSC	DRQ	COR	IDX	ERR
0	V	0	V	0	V	0	0	0	V	0	V	-	0	0	V

Table 88 Read Multiple Ext Command (29h)

Output Parameters To The Device

Sector Count Current	The number of sectors to be transferred low order, bits (7:0).
Sector Count Previous	The number of sectors to be transferred high order, bits (15:8). If 0000h in the Sector Count register is specified, then 65,536 sectors will be transferred.
LBA Low Current	LBA (7:0)
LBA Low Previous	LBA (31:24)
LBA Mid Current	LBA (15:8)
LBA Mid Previous	LBA (39:32)
LBA High Current	LBA (23:16)
LBA High Previous	LBA (47:40)

Input Parameters From The Device

LBA Low (HOB=0)	LBA (7:0) of the address of the first unrecoverable error.
LBA Low (HOB=1)	LBA (31:24) of the address of the first unrecoverable error.
LBA Mid (HOB=0)	LBA (15:8) of the address of the first unrecoverable error.
LBA Mid (HOB=1)	LBA (39:32) of the address of the first unrecoverable error.
LBA High (HOB=0)	LBA (23:16) of the address of the first unrecoverable error.
LBA High (HOB=1)	LBA (47:40) of the address of the first unrecoverable error.

14.21 Read Native Max Address (F8h)

Block Output Registers Command								Command Block Input Registers									
Register	7	6	5	4	3	2	1	0	Register	7	6	5	4	3	2	1	0
Data	-	-	-	-	-	-	-	-	Data	-	-	-	-	-	-	-	-
Feature	-	-	-	-	-	-	-	-	Error	...See Below...							
Sector Count	-	-	-	-	-	-	-	-	Sector Count	-	-	-	-	-	-	-	-
LBA Low	-	-	-	-	-	-	-	-	LBA Low	V	V	V	V	V	V	V	V
LBA Mid	-	-	-	-	-	-	-	-	LBA Mid	V	V	V	V	V	V	V	V
LBA High	-	-	-	-	-	-	-	-	LBA High	V	V	V	V	V	V	V	V
Device	-	L	-	-	-	-	-	-	Device	-	-	-	-	H	H	H	H
Command	1	1	1	1	1	0	0	0	Status	...See Below...							

Error Register								Status Register							
7	6	5	4	3	2	1	0	7	6	5	4	3	2	1	0
CRC	UNC	0	IDN	0	ABT	T0N	AMN	BSY	RDY	DF	DSC	DRQ	COR	IDX	ERR
0	0	0	0	0	V	0	0	0	V	0	-	-	0	0	V

Table 89 Read Native Max Address Command (F8h)

This command returns the native max LBA/CYL of HDD which is not affected by Set Max Address command.

The 48-bit native max address is greater than 268,435,455, the Read Native Max Address command return a value of 268,435,455.

Output Parameters To The Device

- L** LBA mode. Indicates the addressing mode. L=0 specifies CHS mode and L=1 does LBA addressing mode.
- D** The device number bit. Indicates that the device number bit of the Device Register should be specified. D=0 selects the master device and D=1 selects the slave device.
- Indicates that the bit is not used.

Input Parameters From The Device

- LBA Low** In LBA mode, this register contains native max LBA bits 0 - 7. (L=1)
In CHS mode, this register contains native max LBA Low. (L=0)
- LBA High/Mid** In LBA mode, this register contains native max LBA bits 8 - 15 (Mid), 16 - 23 (High). (L=1)
In CHS mode, this register contains native max cylinder number. (L=0)
- H** In LBA mode, this register contains native max LBA bits 24 - 27. (L=1)
In CHS mode, this register contains native max head number. (L=0)
- V** Valid. Indicates that the bit is part of an input parameter and will be set to 0 or 1 by the device.
- Indicates that the bit is not used.

14.22 Read Native Max Address Ext (27h)

Command Block Output Registers									Command Block Input Registers										
Register		7	6	5	4	3	2	1	0	Register		7	6	5	4	3	2	1	0
Data Low		-	-	-	-	-	-	-	-	Data Low		-	-	-	-	-	-	-	-
Data High		-	-	-	-	-	-	-	-	Data High		-	-	-	-	-	-	-	-
Feature	Current	-	-	-	-	-	-	-	-	Error		...See Below...							
	Previous	-	-	-	-	-	-	-	-										
Sector Count	Current	-	-	-	-	-	-	-	-	Sector Count	HOB=0	-	-	-	-	-	-	-	-
	Previous	-	-	-	-	-	-	-	-		HOB=1	-	-	-	-	-	-	-	-
LBA Low	Current	-	-	-	-	-	-	-	-	LBA Low	HOB=0	V	V	V	V	V	V	V	V
	Previous	-	-	-	-	-	-	-	-		HOB=1	V	V	V	V	V	V	V	V
LBA Mid	Current	-	-	-	-	-	-	-	-	LBA Mid	HOB=0	V	V	V	V	V	V	V	V
	Previous	-	-	-	-	-	-	-	-		HOB=1	V	V	V	V	V	V	V	V
LBA High	Current	-	-	-	-	-	-	-	-	LBA High	HOB=0	V	V	V	V	V	V	V	V
	Previous	-	-	-	-	-	-	-	-		HOB=1	V	V	V	V	V	V	V	V
Device		-	1	-	-	-	-	-	-	Device		-	-	-	-	-	-	-	-
Command		0	0	1	0	0	1	1	1	Status		...See Below...							

Error Register								Status Register							
7	6	5	4	3	2	1	0	7	6	5	4	3	2	1	0
CRC	UNC	0	IDN	0	ABT	TON	AMN	BSY	RDY	DF	DSC	DRQ	COR	IDX	ERR
0	0	0	0	0	V	0	0	0	V	0	-	-	0	0	V

Table 90 Read Native Max Address Ext Command (27h)

This command returns the native max LBA of HDD which is not effected by Set Max Address Ext command.

Input Parameters From The Device

LBA Low (HOB=0)	LBA (7:0) of the address of the Native max address.
LBA Low (HOB=1)	LBA (31:24)of the address of the Native max address.
LBA Mid (HOB=0)	LBA (15:8)of the address of the Native max address.
LBA Mid (HOB=1)	LBA (39:32)of the address of the Native max address.
LBA High (HOB=0)	LBA (23:16)of the address of the first Native max address.
LBA High (HOB=1)	LBA (47:40)of the address of the first Native max address.

14.23 Read Sector(s) (20h/21h)

Command Block Output Registers								Command Block Input Registers									
Register	7	6	5	4	3	2	1	0	Register	7	6	5	4	3	2	1	0
Data	-	-	-	-	-	-	-	-	Data	-	-	-	-	-	-	-	-
Feature	-	-	-	-	-	-	-	-	Error	...See Below...							
Sector Count	V	V	V	V	V	V	V	V	Sector Count	V	V	V	V	V	V	V	V
LBA Low	V	V	V	V	V	V	V	V	LBA Low	V	V	V	V	V	V	V	V
LBA Mid	V	V	V	V	V	V	V	V	LBA Mid	V	V	V	V	V	V	V	V
LBA High	V	V	V	V	V	V	V	V	LBA High	V	V	V	V	V	V	V	V
Device	-	L	-	-	H	H	H	H	Device	-	-	-	-	H	H	H	H
Command	0	0	1	0	0	0	0	R	Status	...See Below...							

Error Register								Status Register							
7	6	5	4	3	2	1	0	7	6	5	4	3	2	1	0
CRC	UNC	0	IDN	0	ABT	T0N	AMN	BSY	RDY	DF	DSC	DRQ	COR	IDX	ERR
0	V	0	V	0	V	0	0	0	V	0	V	-	0	0	V

Table 91 Read Sector(s) Command (20h/21h)

The Read Sector(s) command reads one or more sectors of data from disk media, then transfers the data from the device to the host.

The sectors are transferred through the Data Register 16 bits at a time.

If an uncorrectable error occurs, the read will be terminated at the failing sector.

Output Parameters To The Device

Sector Count The number of continuous sectors to be transferred. If zero is specified, then 256 sectors will be transferred.

LBA Low The sector number of the first sector to be transferred. (L=0)

In LBA mode, this register contains LBA bits 0 - 7. (L=1)

LBA High/Mid The cylinder number of the first sector to be transferred. (L=0)

In LBA mode, this register contains LBA bits 8 - 15 (Mid), 16 - 23 (High). (L=1)

H The head number of the first sector to be transferred. (L=0)

In LBA mode, this register contains LBA bits 24 - 27. (L=1)

R The retry bit, but this bit is ignored.

Input Parameters From The Device

Sector Count The number of requested sectors not transferred. This will be zero, unless an unrecoverable error occurs.

LBA Low The sector number of the last transferred sector. (L=0)

In LBA mode, this register contains current LBA bits 0 - 7. (L=1)

LBA High/Mid The cylinder number of the last transferred sector. (L=0)

In LBA mode, this register contains current LBA bits 8 - 15 (Mid), 16 - 23 (High). (L=1)

H The head number of the last transferred sector. (L=0)

In LBA mode, this register contains current LBA bits 24 - 27. (L=1)

14.24 Read Sector(s) Ext (24h)

Command Block Output Registers								Command Block Input Registers									
Register	7	6	5	4	3	2	1	0	Register	7	6	5	4	3	2	1	0
Data Low	-	-	-	-	-	-	-	-	Data Low	-	-	-	-	-	-	-	-
Data High	-	-	-	-	-	-	-	-	Data High	-	-	-	-	-	-	-	-
Feature	Current	-	-	-	-	-	-	-	Error	...See Below...							
	Previous	-	-	-	-	-	-	-									
Sector Count	Current	V	V	V	V	V	V	V	Sector Count	HOB=0	-	-	-	-	-	-	-
	Previous	V	V	V	V	V	V	V	HOB=1	-	-	-	-	-	-	-	-
LBA Low	Current	V	V	V	V	V	V	V	LBA Low	HOB=0	V	V	V	V	V	V	V
	Previous	V	V	V	V	V	V	V	HOB=1	V	V	V	V	V	V	V	V
LBA Mid	Current	V	V	V	V	V	V	V	LBA Mid	HOB=0	V	V	V	V	V	V	V
	Previous	V	V	V	V	V	V	V	HOB=1	V	V	V	V	V	V	V	V
LBA High	Current	V	V	V	V	V	V	V	LBA High	HOB=0	V	V	V	V	V	V	V
	Previous	V	V	V	V	V	V	V	HOB=1	V	V	V	V	V	V	V	V
Device	-	1	-	-	-	-	-	-	Device	-	-	-	-	-	-	-	-
Command	0	0	1	0	0	1	0	0	Status	...See Below...							

Error Register								Status Register							
7	6	5	4	3	2	1	0	7	6	5	4	3	2	1	0
CRC	UNC	0	IDN	0	ABT	TON	AMN	BSY	RDY	DF	DSC	DRQ	COR	IDX	ERR
0	V	0	V	0	V	0	0	0	V	0	V	-	0	0	V

Table 92 Read Sector(s) Ext Command (24h)

The Read Sector(s) Ext command reads from 1 to 65,536 sectors of data from disk media, then transfers the data from the device to the host.

The sectors are transferred through the Data Register 16 bits at a time.

If an uncorrectable error occurs, the read will be terminated at the failing sector.

Output Parameters To The Device

Sector Count Current The number of sectors to be transferred low order, bits (7:0).

Sector Count Previous The number of sectors to be transferred high order, bits (15:8). If 0000h in the Sector Count register is specified, then 65,536 sectors will be transferred.

LBA Low Current LBA (7:0)

LBA Low Previous LBA (31:24)

LBA Mid Current LBA (15:8)

LBA Mid Previous LBA (39:32)

LBA High Current LBA (23:16)

LBA High Previous LBA (47:40)

Input Parameters From The Device

LBA Low (HOB=0) LBA (7:0) of the address of the first unrecoverable error.

LBA Low (HOB=1) LBA (31:24) of the address of the first unrecoverable error.

LBA Mid (HOB=0) LBA (15:8) of the address of the first unrecoverable error.

LBA Mid (HOB=1) LBA (39:32) of the address of the first unrecoverable error.

LBA High (HOB=0) LBA (23:16) of the address of the first unrecoverable error.

LBA High (HOB=1) LBA (47:40) of the address of the first unrecoverable error.

14.25 Read Verify Sector(s) (40h/41h)

Command Block Output Registers								Command Block Input Registers									
Register	7	6	5	4	3	2	1	0	Register	7	6	5	4	3	2	1	0
Data	-	-	-	-	-	-	-	-	Data	-	-	-	-	-	-	-	-
Feature	-	-	-	-	-	-	-	-	Error	...See Below...							
Sector Count	V	V	V	V	V	V	V	V	Sector Count	V	V	V	V	V	V	V	V
LBA Low	V	V	V	V	V	V	V	V	LBA Low	V	V	V	V	V	V	V	V
LBA Mid	V	V	V	V	V	V	V	V	LBA Mid	V	V	V	V	V	V	V	V
LBA High	V	V	V	V	V	V	V	V	LBA High	V	V	V	V	V	V	V	V
Device	-	L	-	-	H	H	H	H	Device	-	-	-	-	H	H	H	H
Command	0	0	1	0	0	0	0	R	Status	...See Below...							

Error Register								Status Register							
7	6	5	4	3	2	1	0	7	6	5	4	3	2	1	0
CRC	UNC	0	IDN	0	ABT	T0N	AMN	BSY	RDY	DF	DSC	DRQ	COR	IDX	ERR
0	V	0	V	0	V	0	0	0	V	0	V	-	0	0	V

Table 93 Read Verify Sector(s) Command (40h/41h)

The Read Verify Sector(s) verifies one or more sectors on the device. No data is transferred to the host.

The difference of Read Sector(s) command and Read Verify Sector(s) command is whether the data is transferred to the host or not.

If an uncorrectable error occurs, the read verify will be terminated at the failing sector.

Output Parameters To The Device

Sector Count The number of continuous sectors to be verified. If zero is specified, then 256 sectors will be verified.

LBA Low The sector number of the first sector to be transferred. (L=0)

In LBA mode, this register contains LBA bits 0 - 7. (L=1)

LBA High/Mid The cylinder number of the first sector to be transferred. (L=0)

In LBA mode, this register contains LBA bits 8 - 15 (Mid), 16 - 23 (High). (L=1)

H The head number of the first sector to be transferred. (L=0)

In LBA mode, this register contains LBA bits 24 - 27. (L=1)

R The retry bit, but this bit is ignored.

Input Parameters From The Device

Sector Count The number of requested sectors not verified. This will be zero, unless an unrecoverable error occurs.

LBA Low The sector number of the last transferred sector. (L=0)

In LBA mode, this register contains current LBA bits 0 - 7. (L=1)

LBA High/Mid The cylinder number of the last transferred sector. (L=0)

In LBA mode, this register contains current LBA bits 8 - 15 (Mid), 16 - 23 (High). (L=1)

H The head number of the last transferred sector. (L=0)

In LBA mode, this register contains current LBA bits 24 - 27. (L=1)

14.26 Read Verify Sector(s) Ext (42h)

Command Block Output Registers								Command Block Input Registers									
Register	7	6	5	4	3	2	1	0	Register	7	6	5	4	3	2	1	0
Data Low	-	-	-	-	-	-	-	-	Data Low	-	-	-	-	-	-	-	-
Data High	-	-	-	-	-	-	-	-	Data High	-	-	-	-	-	-	-	-
Feature	Current	-	-	-	-	-	-	-	Error	...See Below...							
	Previous	-	-	-	-	-	-	-									
Sector Count	Current	V	V	V	V	V	V	V	Sector Count	HOB=0	-	-	-	-	-	-	-
	Previous	V	V	V	V	V	V	V	HOB=1	-	-	-	-	-	-	-	-
LBA Low	Current	V	V	V	V	V	V	V	LBA Low	HOB=0	V	V	V	V	V	V	V
	Previous	V	V	V	V	V	V	V	HOB=1	V	V	V	V	V	V	V	V
LBA Mid	Current	V	V	V	V	V	V	V	LBA Mid	HOB=0	V	V	V	V	V	V	V
	Previous	V	V	V	V	V	V	V	HOB=1	V	V	V	V	V	V	V	V
LBA High	Current	V	V	V	V	V	V	V	LBA High	HOB=0	V	V	V	V	V	V	V
	Previous	V	V	V	V	V	V	V	HOB=1	V	V	V	V	V	V	V	V
Device	-	1	-	-	-	-	-	-	Device	-	-	-	-	-	-	-	-
Command	0	0	1	0	0	0	1	0	Status	...See Below...							

Error Register								Status Register							
7	6	5	4	3	2	1	0	7	6	5	4	3	2	1	0
CRC	UNC	0	IDN	0	ABT	TON	AMN	BSY	RDY	DF	DSC	DRQ	COR	IDX	ERR
0	V	0	V	0	V	0	0	0	V	0	V	-	0	0	V

Table 94 Read Verify Sector(s) Ext Command (42h)

The Read Verify Sector(s) Ext verifies one or more sectors on the device. No data is transferred to the host.

The difference between the Read Sector(s) Ext command and the Read Verify Sector(s) Ext command is whether the data is transferred to the host or not.

If an uncorrectable error occurs, the Read Verify Sector(s) Ext will be terminated at the failing sector.

Output Parameters To The Device

Sector Count Current The number of sectors to be transferred low order, bits (7:0).

Sector Count Previous The number of sectors to be transferred high order, bits (15:8). If 0000h in the Sector Count register is specified, then 65,536 sectors will be verified.

LBA Low Current LBA (7:0)

LBA Low Previous LBA (31:24)

LBA Mid Current LBA (15:8)

LBA Mid Previous LBA (39:32)

LBA High Current LBA (23:16)

LBA High Previous LBA (47:40)

Input Parameters From The Device

LBA Low (HOB=0) LBA (7:0) of the address of the first unrecoverable error.

LBA Low (HOB=1) LBA (31:24) of the address of the first unrecoverable error.

LBA Mid (HOB=0) LBA (15:8) of the address of the first unrecoverable error.

LBA Mid (HOB=1) LBA (39:32) of the address of the first unrecoverable error.

LBA High (HOB=0) LBA (23:16) of the address of the first unrecoverable error.

LBA High (HOB=1) LBA (47:40) of the address of the first unrecoverable error.

14.27 Recalibrate (1xh)

Command Block Output Registers								Command Block Input Registers									
Register	7	6	5	4	3	2	1	0	Register	7	6	5	4	3	2	1	0
Data	-	-	-	-	-	-	-	-	Data	-	-	-	-	-	-	-	-
Feature	-	-	-	-	-	-	-	-	Error	...See Below...							
Sector Count	-	-	-	-	-	-	-	-	Sector Count	-	-	-	-	-	-	-	-
LBA Low	-	-	-	-	-	-	-	-	LBA Low	-	-	-	-	-	-	-	-
LBA Mid	-	-	-	-	-	-	-	-	LBA Mid	-	-	-	-	-	-	-	-
LBA High	-	-	-	-	-	-	-	-	LBA High	-	-	-	-	-	-	-	-
Device	-	-	-	-	-	-	-	-	Device	-	-	-	-	-	-	-	-
Command	0	0	0	1	-	-	-	-	Status	...See Below...							

Error Register								Status Register							
7	6	5	4	3	2	1	0	7	6	5	4	3	2	1	0
CRC	UNC	0	IDN	0	ABT	T0N	AMN	BSY	RDY	DF	DSC	DRQ	COR	IDX	ERR
0	0	0	0	0	V	V	0	0	V	0	V	-	0	0	V

Table 95 Recalibrate Command (1xh)

The Recalibrate command moves the read/write heads from anywhere on the disk to cylinder 0.

If the device cannot reach cylinder 0, T0N (Track 0 Not Found) will be set in the Error Register.

14.28 Security Disable Password (F6h)

Command Block Output Registers								Command Block Input Registers									
Register	7	6	5	4	3	2	1	0	Register	7	6	5	4	3	2	1	0
Data	-	-	-	-	-	-	-	-	Data	-	-	-	-	-	-	-	-
Feature	-	-	-	-	-	-	-	-	Error	...See Below...							
Sector Count	-	-	-	-	-	-	-	-	Sector Count	-	-	-	-	-	-	-	-
LBA Low	-	-	-	-	-	-	-	-	LBA Low	-	-	-	-	-	-	-	-
LBA Mid	-	-	-	-	-	-	-	-	LBA Mid	-	-	-	-	-	-	-	-
LBA High	-	-	-	-	-	-	-	-	LBA High	-	-	-	-	-	-	-	-
Device	-	-	-	-	-	-	-	-	Device	-	-	-	-	-	-	-	-
Command	1	1	1	1	0	1	1	0	Status	...See Below...							

Error Register								Status Register							
7	6	5	4	3	2	1	0	7	6	5	4	3	2	1	0
CRC	UNC	0	IDN	0	ABT	T0N	AMN	BSY	RDY	DF	DSC	DRQ	COR	IDX	ERR
0	0	0	0	0	V	0	0	0	V	0	V	-	0	0	V

Table 96 Security Disable Password Command (F6h)

The Security Disable Password command disables the security mode feature (device lock function).

The Security Disable Password command requests a transfer of a single sector of data from the host including information specified in the following table. Then the device checks the transferred password. If the User Password or Master Password matches the given password, the device disables the security mode feature (device lock function). This command does not change the Master Password which may be re-activated later by setting User Password. This command should be executed in device unlock mode.

Word	Description
00	Control word
	bit 0 : Identifier (1-Mater, 0-User)
	bit 1-15 : Reserved
01-16	Password (32 bytes)
17-255	Reserved

Table 97 Password Information for Security Disable Password command

The device will compare the password sent from this host with that specified in the control word.

Identifier Zero indicates that the device should check the supplied password against the user password stored internally. One indicates that the device should check the given password against the master password stored internally.

14.29 Security Erase Prepare (F3h)

Command Block Output Registers								Command Block Input Registers									
Register	7	6	5	4	3	2	1	0	Register	7	6	5	4	3	2	1	0
Data	-	-	-	-	-	-	-	-	Data	-	-	-	-	-	-	-	-
Feature	-	-	-	-	-	-	-	-	Error	...See Below...							
Sector Count	-	-	-	-	-	-	-	-	Sector Count	-	-	-	-	-	-	-	-
LBA Low	-	-	-	-	-	-	-	-	LBA Low	-	-	-	-	-	-	-	-
LBA Mid	-	-	-	-	-	-	-	-	LBA Mid	-	-	-	-	-	-	-	-
LBA High	-	-	-	-	-	-	-	-	LBA High	-	-	-	-	-	-	-	-
Device	-	-	-	-	-	-	-	-	Device	-	-	-	-	-	-	-	-
Command	1	1	1	1	0	0	1	1	Status	...See Below...							

Error Register								Status Register							
7	6	5	4	3	2	1	0	7	6	5	4	3	2	1	0
CRC	UNC	0	IDN	0	ABT	T0N	AMN	BSY	RDY	DF	DSC	DRQ	COR	IDX	ERR
0	0	0	0	0	V	0	0	0	V	0	V	-	0	0	V

Table 98 Security Erase Prepare Command (F3h)

The Security Erase Prepare Command must be issued immediately before the Security Erase Unit Command to enable device erasing and unlocking.

The Security Erase Prepare Command must be issued immediately before the Format Unit Command. This command is to prevent accidental erasure of the device.

This command does not request to transfer data.

14.30 Security Erase Unit (F4h)

Command Block Output Registers								Command Block Input Registers									
Register	7	6	5	4	3	2	1	0	Register	7	6	5	4	3	2	1	0
Data	-	-	-	-	-	-	-	-	Data	-	-	-	-	-	-	-	-
Feature	-	-	-	-	-	-	-	-	Error	...See Below...							
Sector Count	-	-	-	-	-	-	-	-	Sector Count	-	-	-	-	-	-	-	-
LBA Low	-	-	-	-	-	-	-	-	LBA Low	-	-	-	-	-	-	-	-
LBA Mid	-	-	-	-	-	-	-	-	LBA Mid	-	-	-	-	-	-	-	-
LBA High	-	-	-	-	-	-	-	-	LBA High	-	-	-	-	-	-	-	-
Device	-	-	-	-	-	-	-	-	Device	-	-	-	-	-	-	-	-
Command	1	1	1	1	0	1	0	0	Status	...See Below...							

Error Register								Status Register							
7	6	5	4	3	2	1	0	7	6	5	4	3	2	1	0
CRC	UNC	0	IDN	0	ABT	T0N	AMN	BSY	RDY	DF	DSC	DRQ	COR	IDX	ERR
0	0	0	V	0	V	0	0	0	V	0	V	-	0	0	V

Table 99 Security Erase Unit Command (F4h)

The Security Erase Unit command initializes all user data sectors, then disables the device lock function.

Note that the Security Erase Unit command initializes from LBA 0 to Native Max LBA. Host Max LBA set by Initialize Drive Parameter or Set Max Address command is ignored. So the protected area by Set Max Address command is also initialized.

This command requests to transfer a single sector data from the host including information specified in the following table.

If the password does not match then the device rejects the command with an Aborted error.

Word	Description
00	Control word
	bit 0
	Identifier (1-Mater, 0-User)
	bit 1
	Erase mode (1-Enhanced Erase, 0-Normal Erase)
	bit 2-15
	Reserved
01-16	Password
	(32 bytes)
17-255	Reserved

Table 100 Erase Unit Information

Identifier Zero indicates that the device should check the supplied password against the user password stored internally. One indicates that the device should check the given password against the master password stored internally.

The Security Erase Unit command erases all user data and disables the security mode feature (device lock function). So after completing this command, all user data will be initialized to zero with write operation. At this time, it is not verified with read operation whether the sector of data is initialized correctly. Also, the defective sector information and the reassigned sector information for the device are not updated. The security erase prepare command should be completed immediately prior to the Security Erase Unit command. If the device receives a Security Erase Unit command without a prior Security Erase Prepare command the device aborts the security erase unit command.

This command disables the security mode feature (device lock function), however the master password is still stored internally within the device and may be re-activated later when a new user password is set. If you execute this command on disabling the security mode feature (device lock function), the password sent by the host is NOT compared with the password stored in the device for both the Master Password and the User Password, and then the device only erases all user data.

The execution time of this command is set in Word 89 of Identify Device data information.

The execution time of this command is set in Word 90 of Identify Device data information.

In case of the FDE model, the execution time in Enhanced Erase mode is less than 1 minutes.

14.31 Security Freeze Lock (F5h)

Command Block Output Registers								Command Block Input Registers									
Register	7	6	5	4	3	2	1	0	Register	7	6	5	4	3	2	1	0
Data	-	-	-	-	-	-	-	-	Data	-	-	-	-	-	-	-	-
Feature	-	-	-	-	-	-	-	-	Error	...See Below...							
Sector Count	-	-	-	-	-	-	-	-	Sector Count	-	-	-	-	-	-	-	-
LBA Low	-	-	-	-	-	-	-	-	LBA Low	-	-	-	-	-	-	-	-
LBA Mid	-	-	-	-	-	-	-	-	LBA Mid	-	-	-	-	-	-	-	-
LBA High	-	-	-	-	-	-	-	-	LBA High	-	-	-	-	-	-	-	-
Device	-	-	-	-	-	-	-	-	Device	-	-	-	-	-	-	-	-
Command	1	1	1	1	0	1	0	1	Status	...See Below...							

Error Register								Status Register							
7	6	5	4	3	2	1	0	7	6	5	4	3	2	1	0
CRC	UNC	0	IDN	0	ABT	T0N	AMN	BSY	RDY	DF	DSC	DRQ	COR	IDX	ERR
0	0	0	0	0	V	0	0	0	V	0	-	-	0	0	V

Table 101 Security Freeze Lock Command (F5h)

The Security Freeze Lock Command allows the device to enter frozen mode immediately.

After this command is completed, the command which updates Security Mode Feature (Device Lock Function) is rejected.

Frozen mode is quit only by Power off.

The following commands are rejected when the device is in frozen mode. For detail, refer to "Table 35 Command table for device lock operation" on Page57-58.

- Security Set Password
- Security Unlock
- Security Disable Password
- Security Erase Unit

14.32 Security Set Password (F1h)

Command Block Output Registers								Command Block Input Registers									
Register	7	6	5	4	3	2	1	0	Register	7	6	5	4	3	2	1	0
Data	-	-	-	-	-	-	-	-	Data	-	-	-	-	-	-	-	-
Feature	-	-	-	-	-	-	-	-	Error	...See Below...							
Sector Count	-	-	-	-	-	-	-	-	Sector Count	-	-	-	-	-	-	-	-
LBA Low	-	-	-	-	-	-	-	-	LBA Low	-	-	-	-	-	-	-	-
LBA Mid	-	-	-	-	-	-	-	-	LBA Mid	-	-	-	-	-	-	-	-
LBA High	-	-	-	-	-	-	-	-	LBA High	-	-	-	-	-	-	-	-
Device	-	-	-	-	-	-	-	-	Device	-	-	-	-	-	-	-	-
Command	1	1	1	1	0	0	0	1	Status	...See Below...							

Error Register								Status Register							
7	6	5	4	3	2	1	0	7	6	5	4	3	2	1	0
CRC	UNC	0	IDN	0	ABT	T0N	AMN	BSY	RDY	DF	DSC	DRQ	COR	IDX	ERR
0	0	0	0	0	V	0	0	0	V	0	-	-	0	0	V

Table 102 Security Set Password Command (F1h)

The Security Set Password command enables security mode feature (device lock function), and sets the master password or the user password.

The security mode feature (device lock function) is enabled by this command, and the device is not locked immediately. The device is locked after next COMRESET with Software Setting Preservation disabled or power on reset. When the MASTER password is set by this command, the master password is registered internally, but the device is NOT locked after next power on reset.

This command requests a transfer of a single sector of data from the host including the information specified in the following table.

The data transferred controls the function of this command.

Word	Description
00	Control word
	bit 0 : Identifier (1-Mater, 0-User)
	bit 1-7 : Reserved
	bit 8 : Security level (1-Maximum, 0-High)
	bit 1-15 : Reserved
01-16	Password (32 bytes)
17-18	Master Password Revision Code (valid if Word 0 bit 0 = 1)
19-255	Reserved

Table 103 Security Set Password Information

Identifier	Zero indicates that the device should check the supplied password against the user password stored internally. One indicates that the device should check the given password against the master password stored internally.
Security Level	Zero indicates High level, one indicates Maximum level. If the host sets High level and the password is forgotten, then the Master Password can be used to unlock the device. If the host sets Maximum level and the user password is forgotten, only an Security Erase Prepare/Security Unit command can unlock the device and all data will be lost.
Password	The text of the password - all 32 bytes are always significant.

Master Password The Revision Code field is set with Master password. If Identifier is User, the
Revision Code Revision Code is not set. The Revision Code field is returned in Identify Device
word 92. The valid Revision Codes are 0001h to FFFEh. Default Master Password
Revision Code is FFFEh. Value 0000h and FFFFh is reserved.

The setting of the Identifier and Security level bits interact as follows.

Identifier=User / Security level = High

The password supplied with the command will be saved as the new user password. The security mode feature (lock function) will be enabled from the next power on. The file may then be unlocked by either the user password or the previously set master password.

Identifier=Master / Security level = High

This combination will set a master password but will NOT enable the security mode feature (lock function).

Identifier=User / Security level = Maximum

The password supplied with the command will be saved as the new user password. The security mode feature (lock function) will be enabled from the next power on. The file may then be unlocked by only the user password. The master password previously set is still stored in the file but may NOT be used to unlock the device.

Identifier=Master / Security level = Maximum

This combination will set a master password but will NOT enable the security mode feature (lock function).

14.33 Security Unlock (F2h)

Command Block Output Registers								Command Block Input Registers									
Register	7	6	5	4	3	2	1	0	Register	7	6	5	4	3	2	1	0
Data	-	-	-	-	-	-	-	-	Data	-	-	-	-	-	-	-	-
Feature	-	-	-	-	-	-	-	-	Error	...See Below...							
Sector Count	-	-	-	-	-	-	-	-	Sector Count	-	-	-	-	-	-	-	-
LBA Low	-	-	-	-	-	-	-	-	LBA Low	-	-	-	-	-	-	-	-
LBA Mid	-	-	-	-	-	-	-	-	LBA Mid	-	-	-	-	-	-	-	-
LBA High	-	-	-	-	-	-	-	-	LBA High	-	-	-	-	-	-	-	-
Device	-	-	-	-	-	-	-	-	Device	-	-	-	-	-	-	-	-
Command	1	1	1	1	0	0	1	0	Status	...See Below...							

Error Register								Status Register							
7	6	5	4	3	2	1	0	7	6	5	4	3	2	1	0
CRC	UNC	0	IDN	0	ABT	T0N	AMN	BSY	RDY	DF	DSC	DRQ	COR	IDX	ERR
0	V	0	0	0	V	0	0	0	V	0	-	-	0	0	V

Table 104 Security Unlock Command (F2h)

This command unlocks the password and causes the device to enter device unlock mode. If COMRESET with Software Setting Preservation disable or power on reset is done without executing the Security Disable Password command after this command is completed, the device will be in device lock mode. The password has not been changed yet.

The Security Unlock command requests to transfer a single sector of data from the host including information specified in the following table.

If the Identifier bit is set to master and the file is in high security mode then the password supplied will be compared with the stored master password. If the file is in maximum security mode then the security unlock will be rejected.

If the Identifier bit is set to user, then the file compares the supplied password with the stored user password.

If the password compare fails then the device returns an abort error to the host and decrements the unlock attempt counter. This counter is initially set to 5 and is decremented for each password mismatch. When this counter reaches zero then all password protected commands are rejected until a power off.

Word	Description
00	Control word
	bit 0 : Identifier (1-Master, 0-User)
	bit 1-15 : Reserved
01-16	Password (32 bytes)
17-255	Reserved

Table 105 Security Unlock Information

Identifier Zero indicates that device regards Password as User Password. One indicates that device regards Password as Master Password.

The user can detect if the attempt to unlock the device has failed due to a mismatched password as this is the only reason that an abort error will be returned by the file AFTER the password information has been sent to the device. If an abort error is returned by the device BEFORE the password data has been sent to the file then another problem exists.

14.34 Seek (7xh)

Command Block Output Registers								Command Block Input Registers									
Register	7	6	5	4	3	2	1	0	Register	7	6	5	4	3	2	1	0
Data	-	-	-	-	-	-	-	-	Data	-	-	-	-	-	-	-	-
Feature	-	-	-	-	-	-	-	-	Error	...See Below...							
Sector Count	-	-	-	-	-	-	-	-	Sector Count	-	-	-	-	-	-	-	-
LBA Low	V	V	V	V	V	V	V	V	LBA Low	V	V	V	V	V	V	V	V
LBA Mid	V	V	V	V	V	V	V	V	LBA Mid	V	V	V	V	V	V	V	V
LBA High	V	V	V	V	V	V	V	V	LBA High	V	V	V	V	V	V	V	V
Device	-	L	-	-	H	H	H	H	Device	-	-	-	-	H	H	H	H
Command	0	1	1	1	-	-	-	-	Status	...See Below...							

Error Register								Status Register							
7	6	5	4	3	2	1	0	7	6	5	4	3	2	1	0
CRC	UNC	0	IDN	0	ABT	T0N	AMN	BSY	RDY	DF	DSC	DRQ	COR	IDX	ERR
0	0	0	V	0	V	0	0	0	V	0	V	-	0	0	V

Table 106 Seek Command (7xh)

The Seek command initiates a seek to the designated track and selects the designated head. The device need not be formatted for a seek to execute properly.

Output Parameters To The Device

LBA Low In LBA mode, this register specifies LBA address bits 0 - 7 for seek. (L=1)

LBA High/Mid The cylinder number of the seek.
In LBA mode, this register specifies LBA address bits 8 - 15 (Mid), 16 - 23 (High) for seek. (L=1)

H The head number of the seek.
In LBA mode, this register specifies LBA address bits 24 - 27 for seek. (L=1)

Input Parameters From The Device

LBA Low In LBA mode, this register contains current LBA bits 0 - 7. (L=1)

LBA High/Mid In LBA mode, this register contains current LBA bits 8 - 15 (Mid), 16 - 23 (High). (L=1)

H In LBA mode, this register contains current LBA bits 24 - 27. (L=1)

14.35 Sense Condition (F0h : vendor specific)

Command Block Output Registers								Command Block Input Registers									
Register	7	6	5	4	3	2	1	0	Register	7	6	5	4	3	2	1	0
Data	-	-	-	-	-	-	-	-	Data	-	-	-	-	-	-	-	-
Feature	0	0	0	0	0	0	0	1	Error	...See Below...							
Sector Count	-	-	-	-	-	-	-	-	Sector Count	V	V	V	V	V	V	V	V
LBA Low	-	-	-	-	-	-	-	-	LBA Low	-	-	-	-	-	-	-	N
LBA Mid	-	-	-	-	-	-	-	-	LBA Mid	-	-	-	-	-	-	-	-
LBA High	-	-	-	-	-	-	-	-	LBA High	-	-	-	-	-	-	-	-
Device	-	-	-	-	-	-	-	-	Device	-	-	-	-	-	-	-	-
Command	1	1	1	1	0	0	0	0	Status	...See Below...							

Error Register								Status Register							
7	6	5	4	3	2	1	0	7	6	5	4	3	2	1	0
CRC	UNC	0	IDN	0	ABT	T0N	AMN	BSY	RDY	DF	DSC	DRQ	COR	IDX	ERR
0	0	0	V	0	V	0	0	V	V	V	-	V	-	0	V

Table 107 Sense Condition Command (F0h)

The Sense Condition command is used to sense temperature in a device.

This command is executable without spinning up even if a device is started with No Spin Up option.

If this command is issued at the temperature out of range which is specified for operating condition, the error might be returned with IDN bit 1.

Output Parameters To The Device

Feature The Feature register must be set to 01h. All other value are rejected with setting ABORT bit in status register.

Input Parameters From The Device

Sector Count The Sector Count register contains result value.

Value	Description
00h	Temperature is equal to or lower than -20 degC
01h-FEh	Temperature is (Value / 2 - 20) deg C
FFh	Temperature is higher than 107 degC

N Not recommendable condition for start up. If over stressed condition is detected, this bit will be set to one.

14.36 Set Features (EFh)

Command Block Output Registers								Command Block Input Registers									
Register	7	6	5	4	3	2	1	0	Register	7	6	5	4	3	2	1	0
Data	-	-	-	-	-	-	-	-	Data	-	-	-	-	-	-	-	-
Feature	V	V	V	V	V	V	V	V	Error	...See Below...							
Sector Count	Note.1								Sector Count	-	-	-	-	-	-	-	-
LBA Low	-	-	-	-	-	-	-	-	LBA Low	-	-	-	-	-	-	-	-
LBA Mid	-	-	-	-	-	-	-	-	LBA Mid	-	-	-	-	-	-	-	-
LBA High	-	-	-	-	-	-	-	-	LBA High	-	-	-	-	-	-	-	-
Device	-	-	-	-	-	-	-	-	Device	-	-	-	-	-	-	-	-
Command	1	1	1	0	1	1	1	1	Status	...See Below...							

Error Register								Status Register							
7	6	5	4	3	2	1	0	7	6	5	4	3	2	1	0
CRC	UNC	0	IDN	0	ABT	T0N	AMN	BSY	RDY	DF	DSC	DRQ	COR	IDX	ERR
0	0	0	0	0	V	0	0	0	V	0	-	-	0	0	V

Table 108 Set Features Command (EFh)

The Set Feature command is to establish the following parameters which affect the execution of certain features as shown in below table.

ABT will be set to 1 in the Error Register if the Feature register contains any undefined values.

After power on reset, the device is set to the following features as default.

Write cache	: Enable
Read look-ahead	: Enable
Reverting to power on defaults	: Disable
Device-initiated interface power state transition	: Disable
Software setting preservation	: Enable

Output Parameters To The Device

Feature	Destination code for this command
02H	Enable write cache (Note.2)
03H	Set transfer mode based on value in sector count register
06H	Enable Power-Up in Standby feature set
07H	Power-Up in Standby feature set device spin-up
10H	Enable use of Serial ATA feature
55H	Disable read look-ahead feature
82H	Disable write cache
86H	Disable Power-UP in Standby feature set
90H	Disable use of Serial ATA feature
AAH	Enable read look-ahead feature

Note 1.

When Feature register is 03h (=Set Transfer mode), the Sector Count Register specifies the transfer mechanism. The upper 5 bits define the type of transfer and the low order 3 bits encode the mode value.

	bits (7:3)	bits (2:0)	
PIO Default Transfer Mode	00000	000	
PIO Default Transfer Mode, Disable IORDY	00000	001	
PIO Flow Control Transfer Mode x	00001	nnn	(nnn=000,001,010,011,100)
Multiword DMA mode x	00100	nnn	(nnn=000,001,010)
Ultra DMA mode x	01000	nnn	(nnn=000,001,010,011,100,101)

Note 2.

If the number of auto reassigned sectors reaches the device's reassignment capacity, the write cache function will be automatically disabled. Although the device still accepts the Set Features command (with Feature register = 02h) without error, the write cache function will remain disabled. For current write cache function status, please refer to the Identify Device Information(129word) by Identify Device command. Power off must not be done in 5 seconds after write command completion when write cache is enabled.

Note 3.

When the Feature register is set to 10h or 90h, the value set to the Sector Count register specifies the specific Serial ATA feature to enable or disable.

When the Feature register is set to 10h or 90h, the value set to the Sector Count register specifies the specific Serial ATA feature to enable or disable.

Sector count value	Description
01h	Non-zero buffer offset in DMA setup FIS
02h	DMA setup FIS auto-activate optimization
03h	Device-initiated interface power state transitions
04h	Guaranteed in-order data delivery
06h	Software Settings Preservation

14.37 Set Max Address (F9h)

Command Block Output Registers								Command Block Input Registers									
Register	7	6	5	4	3	2	1	0	Register	7	6	5	4	3	2	1	0
Data	-	-	-	-	-	-	-	-	Data	-	-	-	-	-	-	-	-
Feature	V	V	V	V	V	V	V	V	Error	...See Below...							
Sector Count	-	-	-	-	-	-	-	B	Sector Count	-	-	-	-	-	-	-	-
LBA Low	V	V	V	V	V	V	V	V	LBA Low	V	V	V	V	V	V	V	V
LBA Mid	V	V	V	V	V	V	V	V	LBA Mid	V	V	V	V	V	V	V	V
LBA High	V	V	V	V	V	V	V	V	LBA High	V	V	V	V	V	V	V	V
Device	-	L	-	-	H	H	H	H	Device	-	-	-	-	H	H	H	H
Command	1	1	1	1	1	0	0	1	Status	...See Below...							

Error Register								Status Register							
7	6	5	4	3	2	1	0	7	6	5	4	3	2	1	0
CRC	UNC	0	IDN	0	ABT	T0N	AMN	BSY	RDY	DF	DSC	DRQ	COR	IDX	ERR
0	0	0	0	0	V	0	0	0	V	0	-	-	0	0	V

Table 109 Set Max Address Command (F9h)

The Set Max Address command overwrites the max LBA/CYL of HDD in a range of actual device capacities. The device receives this command, all accesses beyond that LBA/CYL are rejected with setting ABORT bit in status register. Identify device command and Identify device DMA command returns the LBA/CYL which is set via this command as a default value.

This command implement SET Max security extension commands as subcommands. But regardless of Feature register value, the case this command is immediately preceded by a Read Native Max Address command, it is interpreted as a Set Max Address command.

The Read Native Max Address command should be issued and completed immediately prior to issuing Set Max Address command. Otherwise this command is interpreted as a Set Max security extension command which is destined by feature register. If Set Max security mode is in the Locked or Frozen, the Set Max Address command is aborted.

For more information, see “12.9.2 Set Max security extension commands” on Page60.

In CHS mode, LBA High, LBA Mid specify the max cylinder number. The Head number of Device and LBA Low are ignored. The default value(See default CHS in Identify device information) is used for that.

In LBA mode, the Head number of Device, LBA High, LBA Mid and LBA Low specify the max LBA. This command sets this LBA as the max LBA of the device.

After a successful command completion, Identify Device response words (61:60) shall reflect the maximum address set with this command.

If the 48-bit Address feature set is supported, the value placed in Identify Device response words (103:100) shall be the same as the value placed in words (61:60). However, if the device contains greater than 268,435,455 sectors, the capacity addressable with 28-bit commands, and the address requested is 268,435,455, the max address shall be changed to the native maximum address, the value placed in words (61:60) shall be 268,435,455 and the value placed in words (103:100) shall be the native maximum address.

If a host protected area has been established by a Set Max Address Ext command, the device shall return command aborted.

Output Parameters To The Device

Feature

Destination code for this command
01h SET MAX SET PASSWORD
02h SET MAX LOCK
03h SET MAX UNLOCK
04h SET MAX FREEZE LOCK

When the Set Max ADDRESS command is executed, this register is ignored.

B

Option bit for selection whether nonvolatile or volatile. B=0 is volatile condition. When B=1, MAX LBA/CYL which is set by Set Max

ADDRESS command is preserved by POR. When B=0, MAX LBA/CYL which is set by Set Max ADDRESS command will be lost by POR.

LBA Low	in LBA mode, this register contains LBA bits 0 - 7 which is to be input.(L=1)
	In CHS mode, this register is ignored. (L=0)
LBA High/Mid	In LBA mode, this register contains LBA bits 8 - 15 (Mid), 16 - 23 (High) which is to be set. (L=1)
	In CHS mode, this register contains max cylinder number which is to be set. (L=0)
H	In LBA mode, this register contains LBA bits 24 - 27 which is to be input.(L=1)
	In CHS mode, this register is ignored. (L=0)
L	LBA mode.Indicates the addressing mode.L=0 specifies CHS mode and L=1 does LBA addressing mode.
Input Parameters From The Device	
LBA Low	In LBA mode, this register contains Adjusted max LBA bits 0 - 7.(L=1)
	In CHS mode, this register contains max LBA Low(= 63). (L=0)
LBA High/Mid	In LBA mode, this register contains Adjusted max LBA bits 8 - 15 (Mid), 16 - 23 (High). (L=1)
	In CHS mode, this register contains max cylinder number which is set. (L=0)
H	In LBA mode, this register contains Adjusted max LBA bits 24 - 27. (L=1)
	In CHS mode, this register contains max head number(= 15).(L=0)

14.38 Set Max Address Ext (37h)

Command Block Output Registers								Command Block Input Registers									
Register	7	6	5	4	3	2	1	0	Register	7	6	5	4	3	2	1	0
Data Low	-	-	-	-	-	-	-	-	Data Low	-	-	-	-	-	-	-	-
Data High	-	-	-	-	-	-	-	-	Data High	-	-	-	-	-	-	-	-
Feature	Current	-	-	-	-	-	-	-	Error	...See Below...							
	Previous	-	-	-	-	-	-	-									
Sector Count	Current	-	-	-	-	-	-	B	Sector Count	HOB=0	-	-	-	-	-	-	-
	Previous	-	-	-	-	-	-	-	HOB=1	-	-	-	-	-	-	-	-
LBA Low	Current	V	V	V	V	V	V	V	LBA Low	HOB=0	V	V	V	V	V	V	V
	Previous	V	V	V	V	V	V	V	HOB=1	V	V	V	V	V	V	V	V
LBA Mid	Current	V	V	V	V	V	V	V	LBA Mid	HOB=0	V	V	V	V	V	V	V
	Previous	V	V	V	V	V	V	V	HOB=1	V	V	V	V	V	V	V	V
LBA High	Current	V	V	V	V	V	V	V	LBA High	HOB=0	V	V	V	V	V	V	V
	Previous	V	V	V	V	V	V	V	HOB=1	V	V	V	V	V	V	V	V
Device	-	1	-	-	-	-	-	-	Device	-	-	-	-	-	-	-	-
Command	0	0	1	1	0	1	1	1	Status	...See Below...							

Error Register								Status Register							
7	6	5	4	3	2	1	0	7	6	5	4	3	2	1	0
CRC	UNC	0	IDN	0	ABT	TON	AMN	BSY	RDY	DF	DSC	DRQ	COR	IDX	ERR
0	0	0	0	0	V	0	0	0	V	0	-	-	0	0	V

Table 110 Set Max Address Ext Command (37h)

This command is immediately preceded by a Read Native Max Address Ext command.

This command overwrites the maximum number of Address of HDD in a range of actual device capacity. Once device receives this command, all accesses beyond that Address are rejected with setting ABORT bit in status register.

When the address requested is greater than 268,435,455, words (103:100) shall be modified to reflect the requested value, but words (61:60) shall not modified. When the address requested is equal to or less than 268,435,455, words (103:100) shall be modified to reflect the requested value, and words (61:60) shall also be modified.

If this command is not supported, the maximum value to be set exceeds the capacity of the device, a host protected area has been established by a Set Max Address command, the command is not immediately preceded by a Read Native Max Address Ext command, or the device is in the Set Max Locked or Set Max Frozen state, the device shall return command aborted.

The device returns the command aborted for a second non-volatile Set Max Address Ext command until next power on.

Output Parameters To The Device

B

Option bit for selection whether nonvolatile or volatile. B=0 is volatile condition. When B=1, Max Address which is set by Set Max Address Ext command is preserved by POR. When B=0, Max Address which is set by Set Max Address Ext command will be lost by POR.

LBA Low Current

Set Max LBA (7:0).

LBA Low Previous

Set Max LBA (31:24).

LBA Mid Current

Set Max LBA (15:8).

LBA Mid Previous

Set Max LBA (39:32).

LBA High Current

Set Max LBA (23:16).

LBA High Previous

Set Max LBA (47:40).

Input Parameters From The Device

LBA Low (HOB=0)

Set Max LBA (7:0).

LBA Low (HOB=1)

Set Max LBA (31:24).

LBA Mid (HOB=0)

Set Max LBA (15:8).

LBA Mid (HOB=1)

Set Max LBA (39:32).

LBA High (HOB=0)
LBA High (HOB=1)

Set Max LBA (23:16).
Set Max LBA (47:40).

14.39 Set Multiple (C6h)

Command Block Output Registers								Command Block Input Registers									
Register	7	6	5	4	3	2	1	0	Register	7	6	5	4	3	2	1	0
Data	-	-	-	-	-	-	-	-	Data	-	-	-	-	-	-	-	-
Feature	-	-	-	-	-	-	-	-	Error	...See Below...							
Sector Count	V	V	V	V	V	V	V	V	Sector Count	-	-	-	-	-	-	-	-
LBA Low	-	-	-	-	-	-	-	-	LBA Low	-	-	-	-	-	-	-	-
LBA Mid	-	-	-	-	-	-	-	-	LBA Mid	-	-	-	-	-	-	-	-
LBA High	-	-	-	-	-	-	-	-	LBA High	-	-	-	-	-	-	-	-
Device	-	-	-	-	-	-	-	-	Device	-	-	-	-	-	-	-	-
Command	1	1	0	0	0	1	1	0	Status	...See Below...							

Error Register								Status Register							
7	6	5	4	3	2	1	0	7	6	5	4	3	2	1	0
CRC	UNC	0	IDN	0	ABT	T0N	AMN	BSY	RDY	DF	DSC	DRQ	COR	IDX	ERR
0	0	0	0	0	V	0	0	0	V	0	-	-	0	0	V

Table 111 Set Multiple Command (C6h)

The Set Multiple command enables the device to perform Read and Write Multiple commands and establishes the block size for these commands. The block size is the number of sectors to be transferred for each interrupt.

The default block size after power up is 10h, and Read Multiple and Write Multiple commands are enabled.

If an invalid block size is specified, an Abort error will be returned to the host, and Read Multiple and Write Multiple commands will be disabled.

Output Parameters To The Device

Sector Count

The block size to be used for Read Multiple and Write Multiple commands.

Valid block sizes can be selected from 0, 1, 2, 4, 8 or 16. If 0 is specified, then Read Multiple and Write Multiple commands are disabled.

14.40 Sleep (E6h/99h)

Command Block Output Registers								Command Block Input Registers									
Register	7	6	5	4	3	2	1	0	Register	7	6	5	4	3	2	1	0
Data	-	-	-	-	-	-	-	-	Data	-	-	-	-	-	-	-	-
Feature	-	-	-	-	-	-	-	-	Error	...See Below...							
Sector Count	-	-	-	-	-	-	-	-	Sector Count	-	-	-	-	-	-	-	-
LBA Low	-	-	-	-	-	-	-	-	LBA Low	-	-	-	-	-	-	-	-
LBA Mid	-	-	-	-	-	-	-	-	LBA Mid	-	-	-	-	-	-	-	-
LBA High	-	-	-	-	-	-	-	-	LBA High	-	-	-	-	-	-	-	-
Device	-	-	-	-	-	-	-	-	Device	-	-	-	-	-	-	-	-
Command	1	1	1	0	0	1	1	0	Status	...See Below...							

Error Register								Status Register							
7	6	5	4	3	2	1	0	7	6	5	4	3	2	1	0
CRC	UNC	0	IDN	0	ABT	TON	AMN	BSY	RDY	DF	DSC	DRQ	COR	IDX	ERR
0	0	0	0	0	V	0	0	0	V	0	V	-	0	0	V

Table 112 Sleep Command (E6h/99h)

This command is the only way to cause the device to enter Sleep Mode.

When this command is issued, the device confirms the completion of the cached write commands. Then the device is spun down, and the interface becomes inactive. The only way to recover from Sleep Mode is with a software reset or a COMRESET.

If the device is already spun down, the spin down sequence is not executed.

14.41 S.M.A.R.T Function Set (B0h)

Command Block Output Registers								Command Block Input Registers									
Register	7	6	5	4	3	2	1	0	Register	7	6	5	4	3	2	1	0
Data	-	-	-	-	-	-	-	-	Data	-	-	-	-	-	-	-	-
Feature	V	V	V	V	V	V	V	V	Error	...See Below...							
Sector Count	V	V	V	V	V	V	V	V	Sector Count	-	-	-	-	-	-	-	-
LBA Low	-	-	-	-	-	-	-	-	LBA Low	-	-	-	-	-	-	-	-
LBA Mid	0	1	0	0	1	1	1	1	LBA Mid	-	-	-	-	-	-	-	-
LBA High	1	1	0	0	0	0	1	0	LBA High	-	-	-	-	-	-	-	-
Device	-	-	-	-	-	-	-	-	Device	-	-	-	-	-	-	-	-
Command	1	0	1	1	0	0	0	0	Status	...See Below...							

Error Register								Status Register							
7	6	5	4	3	2	1	0	7	6	5	4	3	2	1	0
CRC	UNC	0	IDN	0	ABT	T0N	AMN	BSY	RDY	DF	DSC	DRQ	COR	IDX	ERR
0	0	0	0	0	V	0	0	0	V	0	V	-	0	0	V

Table 113 S.M.A.R.T. Function Set Command (B0h)

The S.M.A.R.T. Function Set command provides access to Attribute Values, Attribute Thresholds and other low level subcommands that can be used for logging and reporting purposes and to accommodate special user needs. The S.M.A.R.T. Function Set command has several separate subcommands which are selectable via the device's Features Register when the S.M.A.R.T. Function Set command is issued by the host.

14.41.1 S.M.A.R.T. Sub commands

In order to select a subcommand the host must write the subcommand code to the device's Features Register before issuing the S.M.A.R.T. Function Set command. The subcommands and their respective codes are listed below.

Code	Subcommand
D0h	S.M.A.R.T. Read Attribute Values
D1h	S.M.A.R.T. Read Attribute Thresholds
D3h	S.M.A.R.T. Save Attribute Values
D4h	S.M.A.R.T. Execute Off-line Immediate
D5h	S.M.A.R.T. Read Log Sector
D6h	S.M.A.R.T. Write Log Sector
D8h	S.M.A.R.T. Enable Operations
D9h	S.M.A.R.T. Disable Operations
DAh	S.M.A.R.T. Return Status
DBh	S.M.A.R.T. Enable/Disable Automatic Off-Line

S.M.A.R.T. Read Attribute Values (Subcommand D0h)

This subcommand returns the device's Attribute Values to the host. Upon receipt of the S.M.A.R.T. Read Attribute Values subcommand from the host, the device saves any updated Attribute Values to the Attribute Data sectors, and then waits for the host to transfer the 512 bytes of Attribute Value information from the device.

S.M.A.R.T. Read Attribute Thresholds (Subcommand D1h)

This subcommand returns the device's Attribute Thresholds to the host. Upon receipt of the S.M.A.R.T. Read Attribute Thresholds subcommand from the host, the device reads the Attribute Thresholds from the Attribute Threshold sectors and then waits for the host to transfer the 512 bytes of Attribute Thresholds information from the device.

S.M.A.R.T. Enable/Disable Attribute Autosave (Subcommand D2h)

This subcommand enables and disables the attribute autosave feature of the device. The S.M.A.R.T. Enable/Disable Attribute Autosave subcommand allows the device to automatically save its updated Attribute Values to the Attribute Data Sector; this subcommand causes the autosave feature to be disabled. The state of the Attribute Autosave feature (either enabled or disabled) will be preserved by the device across power cycle.

A value of 00h written by the host into the device's Sector Count Register before issuing the S.M.A.R.T. Enable/Disable Attribute Autosave subcommand will cause this feature to be disabled. Disabling this feature does

not preclude the device from saving Attribute Values to the Attribute Data sectors during some other normal operation such as during a power-up or power-down.

A value of F1h written by the host into the device's Sector Count Register before issuing the S.M.A.R.T. Enable/Disable Attribute Autosave subcommand will cause this feature to be enabled. Any other non-zero value written by the host into this register before issuing the S.M.A.R.T. Enable/Disable Attribute Autosave subcommand will not change the current Autosave status but the device will respond with the error code specified in "Table 127 S.M.A.R.T. Error Codes" on Page154.

The S.M.A.R.T. Disable Operations subcommand disables the autosave feature along with the device's S.M.A.R.T. operations.

Upon the receipt of the subcommand from the host the device enables or disables the Autosave feature.

S.M.A.R.T. Save Attribute Values (Subcommand D3h)

This subcommand causes the device to immediately save any updated Attribute Values to the device's Attribute Data sector regardless of the state of the Attribute Autosave feature. Upon receipt of the S.M.A.R.T. Save Attribute Values subcommand from the host, the device writes any updated Attribute Values to the Attribute Data sector.

S.M.A.R.T. Execute Off-line Immediate (Subcommand D4h)

This subcommand causes the device to immediately initiate the set of activities that collect Attribute data in an off-line mode (off-line routine) or execute a self-test routine in either captive or off-line mode.

The LBA Low register shall be set to specify the operation to be executed.

LBA Low	Operation to be executed
0	Execute S.M.A.R.T. off-line data collection routine immediately
1	Execute S.M.A.R.T. Short self-test routine immediately in off-line mode
2	Execute S.M.A.R.T. Extended self-test routine immediately in off-line mode
3	Reserved
4	Execute SMART Selective self-test routine immediately in off-line mode
127	Abort off-line mode self-test routine
128	Reserved
129	Execute S.M.A.R.T. Short self-test routine immediately in captive mode
130	Execute S.M.A.R.T. Extended self-test routine immediately in captive mode
131	Reserved
132	Execute SMART selective self-test routine immediately in captive mode

Off-line mode: The device executes command completion before executing the specified routine. During execution of the routine the device will not set BSY nor clear DRDY. If the device is in the process of performing its routine and is interrupted by a new command from the host, the device will abort or suspend its routine and service the host within two seconds after receipt of the new command. After servicing the interrupting command, the device will resume its routine automatically or not start its routine depending on the interrupting command.

Captive mode: When executing self-test in captive mode, the device sets BSY to one and executes the specified self-test routine after receipt of the command. At the end of the routine, the device sets the execution result in the Self-test execution status byte and ATA registers as below and executes command completion.

Status	Set ERR to one when self-test has failed
Error	Set ABRT to one when self-test has failed
LBA Mid	Set to F4h when self-test has failed
LBA High	Set to 2Ch when self-test has failed

SMART Selective self-test routine

When the value in the LBA Low register is 4 or 132, the Selective self-test routine shall be performed. This self-test routine shall include the initial tests performed by the Extended self-test routine plus a selectable read scan. The host shall not write the Selective self-test log while the execution of a Selective self-test command is in progress.

The user may choose to do read scan only on specific areas of the media. To do this, user shall set the test spans desired in the Selective self-test log and set the flags in the Feature flags field of the Selective self-test log to indicate do not perform off-line scan. In this case, the test spans defined shall be read scanned in their entirety. The Selective self-test log is updated as the self-test proceeds indicating test progress. When all specified test spans have been completed, the test is terminated and the appropriate self-test execution status is reported in the S.M.A.R.T. READ DATA response depending on the occurrence of errors. The following figure shows an example of a Selective selftest definition with three test spans defined. In this example, the test terminates when all three test spans have been scanned.

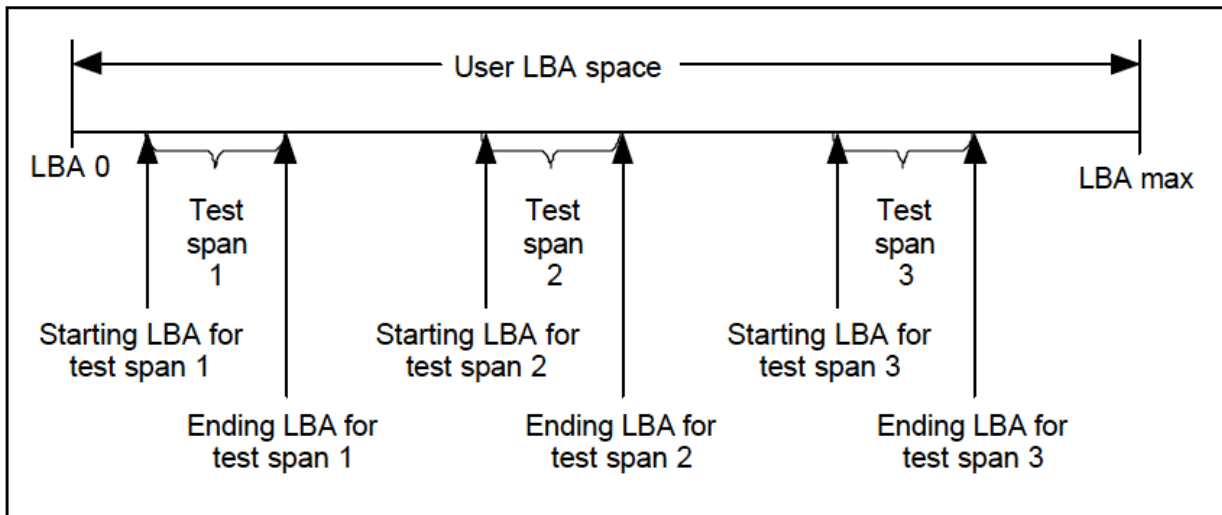

Figure 9 Selective self-test test span example

After the scan of the selected spans described above, a user may wish to have the rest of media read scanned as an off-line scan. In this case, the user shall set the flag to enable off-line scan in addition to the other settings. If an error occurs during the scanning of the test spans, the error is reported in the self-test execution status in the S.M.A.R.T. READ DATA response and the off-line scan is not executed. When the test spans defined have been scanned, the device shall then set the offline scan pending and active flags in the Selective self-test log to one, the span under test to a value greater than five, the self-test execution status in the S.M.A.R.T. READ DATA response to 00h, set a value of 03h in the off-line data collection status in the S.M.A.R.T. READ DATA response and shall proceed to do an off-line read scan through all areas not included in the test spans. This off-line read scan shall be completed as rapidly as possible, no pauses between block reads, and any errors encountered shall not be reported to the host. Instead error locations may be logged for future reallocation. If the device is powered-down before the off-line scan is completed, the off-line scan shall resume when the device is again powered up. From power-up, the resumption of the scan shall be delayed the time indicated in the Selective self-test pending time field in the Selective self-test log. During this delay time the pending flag shall be set to one and the active flag shall be set to zero in the Selective self-test log. Once the time expires, the active flag shall be set to one, and the off-line scan shall resume. When the entire media has been scanned, the off-line scan shall terminate, both the pending and active flags shall be cleared to zero, and the off-line data collection status in the S.M.A.R.T. READ DATA response shall be set to 02h indicating completion.

During execution of the Selective self-test, the self-test execution time byte in the Device S.M.A.R.T. Data Structure may be updated but the accuracy may not be exact because of the nature of the test span segments. For this reason, the time to complete off-line testing and the self-test polling times are not valid. Progress through the test spans is indicated in the selective self-test log.

A COMRESET or software reset shall abort the Selective self-test except when the pending bit is set to one in the Selective self-test log (see 14.41.7 Selective self-test log data structure). The receipt of a S.M.A.R.T. EXECUTE OFF-LINE IMMEDIATE command with 0Fh, Abort off-line test routine, in the LBA Low register shall abort Selective self-test regardless of where the device is in the execution of the command. If a second self-test is issued while a selective self-test is in progress, the selective self-test is aborted and the newly requested self-test is executed.

S.M.A.R.T. Read Log Sector (Subcommand D5h)

This command returns the specified log sector contents to the host.

The 512 bytes data are returned at a command and the Sector Count value shall be set to one. The LBA Low shall be set to specify the log sector address.

Log sector address	Content	Type
00h	Log Directory	Read Only
01h	S.M.A.R.T. Error Log	Read Only
02h	Comprehensive S.M.A.R.T. Error Log	Read Only
06h	S.M.A.R.T. Self-test Log	Read Only
09h	Selective self-test log	Read/Write
80h-9Fh	Host vendor specific	Read/Write

Table 114 Log sector addresses

S.M.A.R.T. Write Log Sector (Subcommand D6h)

This command writes 512 bytes data to the specified log sector.

The 512 bytes data are transferred at a command and the Sector Count value shall be set to one. The LBA Low shall be set to specify the log sector address (Table 114 Log sector addresses). If Read Only log sector is specified, the device returns ABRT error.

S.M.A.R.T. Enable Operations (Subcommand D8h)

This subcommand enables access to all S.M.A.R.T. capabilities within the device. Prior to receipt of a S.M.A.R.T. Enable Operations subcommand, Attribute Values are neither monitored nor saved by the device. The state of S.M.A.R.T. (either enabled or disabled) will be preserved by the device across power cycles. Once enabled, the receipt of subsequent S.M.A.R.T. Enable Operations subcommands will not affect any of the Attribute Values.

Upon receipt of the S.M.A.R.T. Enable Operations subcommand from the host, the device enables S.M.A.R.T. capabilities and functions.

S.M.A.R.T. Disable Operations (Subcommand D9h)

This subcommand disables all S.M.A.R.T. capabilities within the device including the device's attribute autosave feature. After receipt of this subcommand the device disables all S.M.A.R.T. operations. Non self-preserved Attribute Values will no longer be monitored. The state of S.M.A.R.T. (either enabled or disabled) is preserved by the device across power cycles. Note that this subcommand does not preclude the device's power mode attribute autosaving.

Upon receipt of the S.M.A.R.T. Disable Operations subcommand from the host, the device disables S.M.A.R.T. capabilities and functions.

After receipt of the device of the S.M.A.R.T. Disable Operations subcommand from the host, all other S.M.A.R.T. subcommands—with the exception of S.M.A.R.T. Enable Operations—are disabled, and invalid and will be aborted by the device (including the S.M.A.R.T. Disable Operations subcommand), returning the error code as specified in "Table 127 S.M.A.R.T. Error Codes" on Page154.

Any Attribute Values accumulated and saved to volatile memory prior to receipt of the S.M.A.R.T. Disable Operations command will be preserved in the device's Attribute Data Sectors. If the device is re-enabled, these Attribute Values will be updated, as needed, upon receipt of a S.M.A.R.T. Read Attribute Values or S.M.A.R.T. Save Attribute Values command.

S.M.A.R.T. Return Status (Subcommand DAh)

This command is used to communicate the reliability status of the device to the host's request. Upon receipt of the S.M.A.R.T. Return Status subcommand the device asserts BSY, saves any updated Attribute Values to the reserved sector and compares the updated Attribute Values to the Attribute Thresholds.

If the device does not detect a Threshold Exceeded Condition, or detects a Threshold Exceeded Condition but involving attributes are advisory, the device loads 4Fh into the LBA Mid register, C2h into the LBA High register.

If the device detects a Threshold Exceeded Condition for prefailure attributes, the device loads F4h into the LBA Mid register, 2Ch into the LBA High register. Advisory attributes never result in negative reliability condition.

S.M.A.R.T. Enable/Disable Automatic Off-Line (Subcommand DBh)

This subcommand enables and disables the optional feature that cause the device to perform the set of off-line data collection activities that automatically collect attribute data in an off-line mode and then save this data to the device's non-volatile memory. This subcommand may either cause the device to automatically initiate or resume performance of its off-line data collection activities or cause the automatic off-line data collection feature to be disabled. This subcommand also enables and disables the off-line read scanning feature that cause the device to perform the entire read scanning with defect reallocation as the part of the off-line data collection activities.

The Sector Count register shall be set to specify the feature to be enabled or disabled.

Sector Count	Feature Description
00h	Disable Automatic Off-line
01h	Disable Off-line Read Scanning
F8h	Enable Automatic Off-line
F9h	Enable Off-line Read Scanning

A value of zero written by the host into the device's Sector Count register before issuing this subcommand shall cause the automatic off-line data collection feature to be disabled. Disabling this feature does not preclude the device from saving attribute values to non-volatile memory during some other normal operation such as during a power-on or power-off sequence or during an error recovery sequence.

A value of one written by the host into the device's Sector Count register before issuing this subcommand shall cause the off-line read scanning feature to be disabled. The Device does not perform the off-line read scanning at the off-line data collection activities which is initiated by the S.M.A.R.T. Execute Off-line Immediate(Subcommand D4h) or automatically if the off-line read scanning feature is disabled.

A value of F8h written by the host into the device's Sector Count register before issuing this subcommand shall cause the automatic Off-line data collection feature to be enabled.

A value of F9 written by the host into the device's Sector Count register before issuing this subcommand shall cause the off-line read scanning feature to be enabled. The Device perform the off-line read scanning at the off-line data collection activities which is initiated by the S.M.A.R.T. Execute Off-line Immediate(Subcommand D4h) even if the automatic off-line feature is disabled.

Any other non-zero value written by the host into this register before issuing this subcommand is vendor specific and will not change the current Automatic Off-Line Data Collection and Off-line Read Scanning status, but device may respond with the error code specified in "Table 127 S.M.A.R.T. Error Codes" on Page154.

14.41.2 Device Attributes Data Structure

The following defines the 512 bytes that make up the Attribute Value information. This data structure is accessed by the host in its entirety using the S.M.A.R.T. Read Attribute Values subcommand. All multi-byte fields shown in these data structures follow the ATA/ATAPI-6 specification for byte ordering, namely that the least significant byte occupies the lowest numbered byte address location in the field.

Description	Bytes	Offset	Format	Value
Data Structure Revision Number	2	00h	binary	0010h
1 st Device Attribute	12	02h	(*1)	(*2)
...	..			
...	..			
30 th Device Attribute	12	15Eh	(*1)	(*2)
Off-line data collection status	1	16Ah	(*1)	(*2)
Self-test execution status	1	16Bh	(*1)	(*2)
Total time in seconds to complete off-line data collection activity	2	16Ch	(*1)	(*2)
Current segment pointer	1	16Eh	(*1)	(*2)
Off-line data collection capability	1	16Fh	(*1)	5Bh
S.M.A.R.T. capability	2	170h	(*1)	0003h
S.M.A.R.T. device error logging capability	1	172h	(*1)	01h
Self-test failure check point	1	173h	(*1)	(*2)
Short self-test completion time in minutes	1	174h	(*1)	(*2)
Extended self-test completion time in minutes	1	175h	(*1)	(*2)
Reserved	12	176h		(*3)
Vendor specific	125	182h		(*3)
Data structure checksum	1	1FFh	(*1)	(*2)
	512			

(*1) - See following definitions

(*2) - Value varied by actual operating condition

(*3) - Filled with 00h

Table 115 Device Attribute Data Structure

14.41.2.1 Data Structure Revision Number

The Data Structure Revision Number identifies which version of this data structure is implemented by the device. This revision number will be set to 0010h. This revision number identifies both the Attribute Value and Attribute Threshold Data structures.

14.41.2.2 Individual Attribute Data Structure

The following defines the 12 bytes that make up the information for each Attribute entry in the Device Attribute Data Structure.

Description	Bytes	Offset	Format
Attribute ID Number (01h to FFh)	1	00h	binary
Status Flags	2	01h	bit flags
Bit 0 Pre-Failure/Advisory			
Bit 1 On-line Collection			
Bit 2-5 Reserved (may either 0 or 1)			
Bit 6-15 Reserved (all 0)			
Attribute Value (valid values from 01h to FEh)	1	03h	binary
00h invalid for attribute value – not to be used			
01h minimum value			
64h initial value for all attributes prior to any data collection			
FDh maximum value			
FEh value is not valid			
FFh invalid for attribute value - not to be used			
Reserved (may not be 0)	1	04h	binary
Reserved (may not be 0)	6	05h	binary
Reserved (00h)	1	0Bh	binary
Total Bytes	12		

Table 116 Individual Attribute Data Structure

Attribute ID Numbers: Any non-zero value in the Attribute ID Number indicates an active attribute. The device supports following Attribute ID Numbers. Those marked with (*) indicate that corresponding Attribute Values can be either collected on-line or off-line. Those marked with (**) indicate that corresponding Attribute Values is only for Free-fall sensor supported model.

ID	Attribute Name
0	Indicates that this entry in the data structure is not used
1	Raw Read Error Rate (*)
2	Throughput Performance (*)
3	Spin Up Time
4	Start/Stop Count
5	Reallocated Sector Count
7	Seek Error Rate
8	Seek Time Performance (*)
9	Power-On Hours Count
10	Spin Retry Count
12	Device Power Cycle Count
160	Free-fall Sensor Self Test Result (**)
191	G Sense error rate
192	Power off retract count
193	Load/Unload cycle count
194	Device Temperature
196	Reallocation Event Count
197	Current Pending Sector Count
198	Off-Line Scan Uncorrectable Sector Count
199	Ultra DMA CRC Error Count
223	Load Retry Count
254	Free-fall Sensor Work Count

Status Flag Definitions:

Bit	Flag Name	Definition
0	Pre-Failure/Advisory bit	If bit = 0, an Attribute Value less than or equal to its corresponding Attribute Threshold indicates an Advisory condition where the usage or age of the device has exceeded its intended design life period. If bit = 1, an Attribute Value less than or equal to its corresponding Attribute Threshold indicates a Pre-Failure condition where imminent loss of data is being predicted.
1	On-Line Collective bit	If bit = 0, the Attribute Value is updated only during Off-Line testing. If bit = 1, the Attribute Value is updated during On-Line testing or during both On-Line and Off-Line testing.
2-5	Reserved bits	may either 0 or 1
6-15	Reserved bits	Always 0

Table 117 Status Flag Definitions

Normalized Values: The device will perform conversion of the raw Attribute Values to transform them into normalized values, which the host can then compare with the Threshold values. A Threshold is the excursion limit for a normalized Attribute Value. In normalizing the raw data, the device will perform any necessary statistical validity checks to ensure that an instantaneous raw value is not improperly reflected in the normalized Attribute Value (i.e., one read error in the first 10 reads being interpreted as exceeding the read error rate threshold when the subsequent 1 billion reads all execute without error). The end points for the normalized values for all Attributes will be 1 (01h) at the low end, and 100 (64h) at the high end for the device. For Performance and Error Rate Attributes, values greater than 100 are also possible, up to a maximum value of 253 (FDh).

14.41.2.3 Off-Line Data Collection Status

The value of this byte defines the current status of the off-line activities of the device. Bit 7 indicates Automatic Off-Line Data Collection Status.

Bit 7	Automatic Off-Line Data Collection Status
0	Automatic Off-Line Data Collection is disabled.
1	Automatic Off-Line Data Collection is enabled.

Bits 0 thru 6 represents a hexadecimal status value reported by the device.

Value	Definition
0	Off-line data collection never started
2	All segments completed without errors. In this case, current segment pointer equals to total segments required.
4	Off-line data collection suspended by interrupting command
5	Off-line data collecting aborted by interrupting command
6	Off-line data collection aborted with fatal error

14.41.2.4 Self-test execution status

Bit	Definition
0-3	Percent Self-test remaining An approximation of the percent of the self-test routine remaining until completion in ten percent increments. Valid values are 0 through 9.
4-7	Current Self-test execution status
0	The self-test routine completed without error or has never been run
1	The self-test routine aborted by the host
2	The self-test routine interrupted by the host with a hard or soft reset
3	The device was unable to complete the self-test routine due to a fatal error or unknown test error
4	The self-test routine completed with unknown element failure
5	The self-test routine completed with electrical element failure
6	The self-test routine completed with servo element failure
7	The self-test routine completed with read element failure
15	The self-test routine in progress

14.41.2.5 Total Time in Seconds to Complete Off-line Data Collection Activity

This field tells the host how many seconds the device requires to complete the off-line data collection activity.

14.41.2.6 Current Segment Pointer

This byte is a counter indicating the next segment to execute as an off-line data collection activity. Because the number of segments is 1, 01h is always returned in this field.

14.41.2.7 Off-Line Data Collection Capability

Bit	Definition
0	Execute Off-line Immediate implemented bit
0	S.M.A.R.T. Execute Off-line Immediate subcommand is not implemented
1	S.M.A.R.T. Execute Off-line Immediate subcommand is implemented
1	Enable/disable Automatic Off-line implemented bit
0	S.M.A.R.T. Enable/disable Automatic Off-line subcommand is not implemented
1	S.M.A.R.T. Enable/disable Automatic Off-line subcommand is implemented
2	abort/restart off-line by host bit
0	The device will suspend off-line data collection activity after an interrupting command and resume it after some vendor specific event
1	The device will abort off-line data collection activity upon receipt of a new command
3	Off-line Read Scanning implemented bit
0	The device does not support Off-line Read Scanning
1	The device supports Off-line Read Scanning
4	Self-test implemented bit
0	Self-test routine is not implemented
1	Self-test routine is implemented
5	Reserved (0)
6	Selective self-test implemented bit
0	Selective self-test routine is not implemented
1	Selective self-test routine is implemented
7	Reserved (0)

14.41.2.8 S.M.A.R.T. Capability

This word of bit flags describes the S.M.A.R.T. capabilities of the device. The device will return 03h indicating that the device will save its Attribute Values prior to going into a power saving mode and supports the S.M.A.R.T. ENABLE/DISABLE ATTRIBUTE AUTOSAVE command.

Bit	Definition
0	Pre-power mode attribute saving capability If bit = 1, the device will save its Attribute Values prior to going into a power saving mode (Standby or Sleep mode).
1	Attribute autosave capability If bit = 1, the device supports the S.M.A.R.T. ENABLE/DISABLE ATTRIBUTE AUTOSAVE command.
2-15	Reserved (0)

14.41.2.9 Error Logging Capability

Bit	Definition
7-1	Reserved (0)
0	Error Logging support bit If bit = 1, the device supports the Error Logging

14.41.2.10 Self-test failure check point

This byte indicates the section of self-test where the device detected a failure.

14.41.2.11 Self-test completion time

These bytes are the minimum time in minutes to complete self-test.

14.41.2.12 Data Structure Checksum

The Data Structure Checksum is the 2's compliment of the result of a simple 8-bit addition of the first 511 bytes in the data structure.

14.41.3 Device Attribute Thresholds Data Structure

The following defines the 512 bytes that make up the Attribute Threshold information. This data structure is accessed by the host in its entirety using the S.M.A.R.T. Read Attribute Thresholds. All multi-byte fields shown in these data structures follow the ATA/ATAPI-6 specification for byte ordering, namely that the least significant byte occupies the lowest numbered byte address location in the field.

The sequence of active Attribute Thresholds will appear in the same order as their corresponding Attribute Values.

Description	Bytes	Offset	Format	Value
Data Structure Revision Number	2	00h	binary	0010h
1 st Attribute Threshold	12	02h	(*1)	(*2)
...	..			
...	..			
30 th Attribute Threshold	12	15Eh	(*1)	(*2)
Reserved	18	16Ah		(*3)
Vendor specific	131	17Ch		(*3)
Data structure checksum	1	1FFh		(*2)
	512			

(*1) - See following definitions

(*2) - Value varied by actual operating condition

(*3) - Filled with 00h

Table 118 Device Attribute Thresholds Data Structure

14.41.3.1 Data Structure Revision Number

This value is the same as the value used in the Device Attributes Values Data Structure.

14.41.3.2 Individual Thresholds Data Structure

The following defines the 12 bytes that make up the information for each Threshold entry in the Device Attribute Thresholds Data Structure. Attribute entries in the Individual Threshold Data Structure is in the same order and correspond to the entries in the Individual Attribute Data Structure.

Description	Bytes	Offset	Format
Attribute ID Number (01h to FFh)	1	00h	binary
Attribute Threshold (for comparison with Attribute Values from 00h to FFh)	1	01h	binary
00h -	"always passing" threshold value to be used for code test purposes		
01h -	minimum value for normal operation		
FDh -	maximum value for normal operation		
FEh -	invalid for threshold value		
FFh -	"always failing" threshold value to be used for code test purposes		
Reserved (00h)	10	02h	binary
Total Bytes	12		

Table 119 Individual Threshold Data Structure

14.41.3.3 Attribute ID Numbers

Attribute ID Numbers supported by the device are the same as Attribute Values Data Structures.

14.41.3.4 Attribute Threshold

These values are preset at the factory and are not meant to be changeable. However, the host might use " S.M.A.R.T. Write Attribute Threshold" subcommand to override these preset values in the Threshold sectors.

14.41.3.5 Data Structure Checksum

The Data Structure Checksum is the 2's compliment of the result of a simple 8-bit addition of the first 511 bytes in the data structure.

14.41.4 S.M.A.R.T. Log Directory

Following table defines the 512 bytes that make up the S.M.A.R.T. Log Directory. The S.M.A.R.T. Log Directory is on S.M.A.R.T. Log Address zero and is defined as one sector long.

Description	Bytes	Offset
S.M.A.R.T. Logging Version	2	00h
Number of sectors in the log at log address 1	1	02h
Reserved	1	03h
Number of sectors in the log at log address 2	1	04h
Reserved	1	05h
...
Number of sectors in the log at log address 255	1	1FEh
Reserved	1	1FFh
	512	

Table 120 SMART Log Directory

The value of the S.M.A.R.T. Logging Version word shall be 01h. The logs at log addresses 80-9Fh are defined as 16 sectors long.

14.41.5 S.M.A.R.T. error log sector

The following defines the 512 bytes that make up the S.M.A.R.T. error log sector. All multi-byte fields shown in these data structures follow the ATA/ATAPI-6 specifications for byte ordering.

Description	Bytes	Offset
S.M.A.R.T. error log version	1	00h
Error log pointer	1	01h
1 st error log data structure	90	02h
2 nd error log data structure	90	5Ch
3 rd error log data structure	90	B6h
4 th error log data structure	90	110h
5 th error log data structure	90	16Ah
Device error count	2	1C4h
Reserved	57	1C6h
Data structure checksum	1	1FFh
	512	

Table 121 S.M.A.R.T. error log sector

14.41.5.1 S.M.A.R.T. error log version

This value is set to 01h.

14.41.5.2 Error log pointer

This points the most recent error log data structure. Only values 1 through 5 are valid.

14.41.5.3 Device error count

This field contains the total number of errors. The value will not roll over.

14.41.5.4 Error log data structure

Data format of each error log structure is shown below.

Description	Bytes	Offset
1 st error log data structure	12	00h
2 nd error log data structure	12	0Ch
3 rd error log data structure	12	18h
4 th error log data structure	12	24h
5 th error log data structure	12	30h
Error data structure	30	3Ch
	90	

Table 122 Error log data structure

Command data structure: Data format of each command data structure is shown below.

Description	Bytes	Offset
Device Control register	1	00h
Features register	1	01h
Sector count register	1	02h
LBA Low register	1	03h
LBA Mid register	1	04h
LBA High register	1	05h
Device register	1	06h
Command register	1	07h
Timestamp(milliseconds from Power On)	4	08h
	12	

Table 123 Command data structure

Error data structure: Data format of error data structure is shown below.

Description	Bytes	Offset
Reserved	1	00h
Error register	1	01h
Sector count register	1	02h
LBA Low register	1	03h
LBA Mid register	1	04h
LBA High register	1	05h
Device register	1	06h
Status register	1	07h
Extended error data (vendor specific)	19	08h
State	1	1Bh
Life timestamp (hours)	2	1Ch
	30	

Table 124 Error data structure

State field contains a value indicating the device state when command was issued to the device.

Value	State
x0h	Unknown
x1h	Sleep
x2h	Standby
x3h	Active/Idle
x4h	S.M.A.R.T. Off-line or Self-test
x5h-xAh	Reserved
xBh-xFh	Vendor specific

Note: The value of x is vendor specific

14.41.6 Self-test log data structure

The following defines the 512 bytes that make up the Self-test log sector. All multi-byte fields shown in these data structures follow the ATA/ATAPI-7 specifications for byte ordering.

Description	Bytes	Offset
Data structure revision	2	00h
Self-test number	1	n*18h+02h
Self-test execution status	1	n*18h+03h
Life time power on hours	2	n*18h+04h
Self-test failure check point	1	n*18h+06h
LBA of first failure	4	n*18h+07h
Vendor specific	15	n*18h+0Bh
...		
Vendor specific	2	1FAh
Self-test log pointer	1	1FCh
Reserved	2	1FDh
Data structure checksum	1	1FFh
	512	

Note: n is 0 through 20

Table 125 Self-test log data structure

The data structure contains the descriptor of Self-test that the device has performed. Each descriptor is 24 bytes long and the self-test data structure is capable to contain up to 21 descriptors. After 21 descriptors has been recorded, the oldest descriptor will be overwritten with new descriptor. Self-test log pointer points the most recent descriptor. When there is no descriptor the value is 0. When there is descriptor(s) the value is 1 through 21.

14.41.7 Selective self-test log data structure

The Selective self-test log is a log that may be both written and read by the host. This log allows the host to select the parameters for the self-test and to monitor the progress of the self-test. The following table defines the contents of the Selective self-test log which is 512 bytes long. All multi-byte fields shown in these data structures follow the specifications for byte ordering.

Description	Bytes	Offset	Read/Write
Data structure revision	2	00h	R/W
Starting LBA for test span 1	8	02h	R/W
Ending LBA for test span 1	8	0Ah	R/W
Starting LBA for test span 2	8	12h	R/W
Ending LBA for test span 2	8	1Ah	R/W
Starting LBA for test span 3	8	22h	R/W
Ending LBA for test span 3	8	2Ah	R/W
Starting LBA for test span 4	8	32h	R/W
Ending LBA for test span 4	8	3Ah	R/W
Starting LBA for test span 5	8	42h	R/W
Ending LBA for test span 5	8	4Ah	R/W
Reserved	256	52h	Reserved
Vendor specific	154	152h	Vendor specific
Current LBA under test	8	1ECh	Read
Current span under test	2	1F4h	Read
Feature flags	2	1F6h	R/W
Vendor specific	4	1F8h	Vendor specific
Selective self test pending time	2	1FCh	R/W
Reserved	1	1FEh	Reserved
Data structure checksum	1	1FFh	R/W
	512		

Table 126 Selective self-test log data structure

14.41.8 Error Reporting

The following table shows the values returned in the Status and Error Registers when specific error conditions are encountered by a device.

Error Condition	Status Register	Error Register
A S.M.A.R.T. FUNCTION SET command was received by the device without the required key being loaded into the LBA High and LBA Mid registers.	51h	04h
A S.M.A.R.T. FUNCTION SET command was received by the device with a subcommand value in the Features Register that is either invalid or not supported by this device.	51h	04h
A S.M.A.R.T. FUNCTION SET command subcommand other than S.M.A.R.T. ENABLE OPERATIONS was received by the device while the device was in a "S.M.A.R.T. disabled" state.	51h	04h
The device is unable to read its Attribute Values or Attribute Thresholds data structure.	51h	10h or 40h
The device is unable to write to its Attribute Values data structure.	51h	10h or 01h

Table 127 S.M.A.R.T. Error Codes

14.42 Standby (E2h/96h)

Command Block Output Registers								Command Block Input Registers									
Register	7	6	5	4	3	2	1	0	Register	7	6	5	4	3	2	1	0
Data	-	-	-	-	-	-	-	-	Data	-	-	-	-	-	-	-	-
Feature	-	-	-	-	-	-	-	-	Error	...See Below...							
Sector Count	V	V	V	V	V	V	V	V	Sector Count	-	-	-	-	-	-	-	-
LBA Low	-	-	-	-	-	-	-	-	LBA Low	-	-	-	-	-	-	-	-
LBA Mid	-	-	-	-	-	-	-	-	LBA Mid	-	-	-	-	-	-	-	-
LBA High	-	-	-	-	-	-	-	-	LBA High	-	-	-	-	-	-	-	-
Device	-	-	-	-	-	-	-	-	Device	-	-	-	-	-	-	-	-
Command	1	1	1	0	0	0	1	0	Status	...See Below...							
Error Register								Status Register									
7	6	5	4	3	2	1	0	7	6	5	4	3	2	1	0		
CRC	UNC	0	IDN	0	ABT	T0N	AMN	BSY	RDY	DF	DSC	DRQ	COR	IDX	ERR		
0	0	0	0	0	V	0	0	0	V	0	V	-	0	0	V		

Table 128 Standby Command (E2h/96h)

The Standby command causes the device to enter the Standby Mode immediately, and set auto power down timeout parameter(standby timer).

When this command is issued, the device confirms the completion of the cached write commands. Then the device is spun down, but the interface remains active.

If the device is already spun down, the spin down sequence is not executed.

During the Standby mode the device will respond to commands, but there is a delay while waiting for the spindle to reach operating speed.

The timer starts counting down when the device returns to Idle mode.

Output Parameters To The Device

Sector Count Timeout Parameter. If zero, then the automatic power down sequence is disabled. If non-zero, then the automatic power down sequence is enabled, and the timeout interval is shown below:

Value	Timeout
0	Timer disabled
1-240	Value * 5
241-251	(Value-240) * 30 minutes
252	21 minutes
253	8 hours
254	Reserved
255	21 minutes 15 seconds

When the automatic power down sequence is enabled, the drive will enter Standby mode automatically if the timeout interval expires with no drive access from the host. The timeout interval will be reinitialized if there is a drive access before the timeout interval expires.

14.43 Standby Immediate (E0h/94h)

Command Block Output Registers								Command Block Input Registers									
Register	7	6	5	4	3	2	1	0	Register	7	6	5	4	3	2	1	0
Data	-	-	-	-	-	-	-	-	Data	-	-	-	-	-	-	-	-
Feature	-	-	-	-	-	-	-	-	Error	...See Below...							
Sector Count	-	-	-	-	-	-	-	-	Sector Count	-	-	-	-	-	-	-	-
LBA Low	-	-	-	-	-	-	-	-	LBA Low	-	-	-	-	-	-	-	-
LBA Mid	-	-	-	-	-	-	-	-	LBA Mid	-	-	-	-	-	-	-	-
LBA High	-	-	-	-	-	-	-	-	LBA High	-	-	-	-	-	-	-	-
Device	-	-	-	-	-	-	-	-	Device	-	-	-	-	-	-	-	-
Command	1	1	1	0	0	0	0	0	Status	...See Below...							

Error Register								Status Register							
7	6	5	4	3	2	1	0	7	6	5	4	3	2	1	0
CRC	UNC	0	IDN	0	ABT	T0N	AMN	BSY	RDY	DF	DSC	DRQ	COR	IDX	ERR
0	0	0	0	0	V	0	0	0	V	0	V	-	0	0	V

Table 129 Standby Immediate Command (E0h/94h)

The Standby Immediate command causes the device to enter Standby mode immediately. When this command is issued, the device confirms the completion of the cached write commands. Then the device is spun down, but the interface remains active. If the device is already spun down, the spin down sequence is not executed. During the Standby mode, the device will respond to commands, but there is a delay while waiting for the spindle to reach operating speed. The Standby Immediate command will not affect the auto power down timeout parameter.

14.44 Write Buffer (E8h)

Command Block Output Registers								Command Block Input Registers									
Register	7	6	5	4	3	2	1	0	Register	7	6	5	4	3	2	1	0
Data	-	-	-	-	-	-	-	-	Data	-	-	-	-	-	-	-	-
Feature	-	-	-	-	-	-	-	-	Error	...See Below...							
Sector Count	-	-	-	-	-	-	-	-	Sector Count	-	-	-	-	-	-	-	-
LBA Low	-	-	-	-	-	-	-	-	LBA Low	-	-	-	-	-	-	-	-
LBA Mid	-	-	-	-	-	-	-	-	LBA Mid	-	-	-	-	-	-	-	-
LBA High	-	-	-	-	-	-	-	-	LBA High	-	-	-	-	-	-	-	-
Device	-	-	-	-	-	-	-	-	Device	-	-	-	-	-	-	-	-
Command	1	1	1	0	1	0	0	0	Status	...See Below...							

Error Register								Status Register							
7	6	5	4	3	2	1	0	7	6	5	4	3	2	1	0
CRC	UNC	0	IDN	0	ABT	T0N	AMN	BSY	RDY	DF	DSC	DRQ	COR	IDX	ERR
0	0	0	0	0	V	0	0	0	V	0	-	-	0	0	V

Table 130 Write Buffer Command (E8h)

The Write Buffer command transfers a sector of data from the host to the sector buffer of the device. The sectors of data are transferred through the Data Register 16 bits at a time.

The Read Buffer and Write Buffer commands are synchronized such that sequential Write Buffer and Read Buffer commands access the same 512 byte within the buffer.

14.45 Write DMA (CAh/CBh)

Command Block Output Registers								Command Block Input Registers									
Register	7	6	5	4	3	2	1	0	Register	7	6	5	4	3	2	1	0
Data	-	-	-	-	-	-	-	-	Data	-	-	-	-	-	-	-	-
Feature	-	-	-	-	-	-	-	-	Error	...See Below...							
Sector Count	V	V	V	V	V	V	V	V	Sector Count	V	V	V	V	V	V	V	V
LBA Low	V	V	V	V	V	V	V	V	LBA Low	V	V	V	V	V	V	V	V
LBA Mid	V	V	V	V	V	V	V	V	LBA Mid	V	V	V	V	V	V	V	V
LBA High	V	V	V	V	V	V	V	V	LBA High	V	V	V	V	V	V	V	V
Device	-	L	-	-	H	H	H	H	Device	-	-	-	-	H	H	H	H
Command	1	1	0	0	1	0	1	R	Status	...See Below...							

Error Register								Status Register							
7	6	5	4	3	2	1	0	7	6	5	4	3	2	1	0
CRC	UNC	0	IDN	0	ABT	T0N	AMN	BSY	RDY	DF	DSC	DRQ	COR	IDX	ERR
V	0	0	V	0	V	0	0	0	V	V	V	-	0	0	V

Table 131 Write DMA Command (CAh/CBh)

The Write DMA command transfers one or more sectors of data from the host to the device, then the data is written to the disk media.

The sectors of data are transferred through the Data Register 16 bits at a time.

The host initializes a slave-DMA channel prior to issuing the command. Data transfers are qualified by DMARQ and are performed by the slave-DMA channel. The device issues only one interrupt per command to indicate that data transfer has terminated and status is available.

If an uncorrectable error occurs, the write will be terminated at the failing sector.

Output Parameters To The Device

Sector Count The number of continuous sectors to be transferred. If zero is specified, then 256 sectors will be transferred.

LBA Low The sector number of the first sector to be transferred. (L=0)
In LBA mode, this register contains LBA bits 0 - 7. (L=1)

LBA High/Mid The cylinder number of the first sector to be transferred. (L=0)
In LBA mode, this register contains LBA bits 8 - 15 (Mid), 16 - 23 (High). (L=1)

H The head number of the first sector to be transferred. (L=0)
In LBA mode, this register contains LBA bits 24 - 27. (L=1)

R The retry bit, but this bit is ignored.

Input Parameters From The Device

Sector Count The number of requested sectors not transferred. This will be zero, unless an unrecoverable error occurs.

LBA Low The sector number of the last transferred sector. (L=0)
In LBA mode, this register contains current LBA bits 0 - 7. (L=1)

LBA High/Mid The cylinder number of the last transferred sector. (L=0)
In LBA mode, this register contains current LBA bits 8 - 15 (Mid), 16 - 23 (High). (L=1)

H The head number of the last transferred sector. (L=0) In LBA mode, this register contains current LBA bits 24 - 27. (L=1)

14.46 Write DMA Ext (35h)

Command Block Output Registers									Command Block Input Registers								
Register	7	6	5	4	3	2	1	0	Register	7	6	5	4	3	2	1	0
Data Low	-	-	-	-	-	-	-	-	Data Low	-	-	-	-	-	-	-	-
Data High	-	-	-	-	-	-	-	-	Data High	-	-	-	-	-	-	-	-
Feature	Current	-	-	-	-	-	-	-	Error	...See Below...							
	Previous	-	-	-	-	-	-	-									
Sector Count	Current	V	V	V	V	V	V	V	Sector Count	HOB=0	-	-	-	-	-	-	-
	Previous	V	V	V	V	V	V	V	HOB=1	-	-	-	-	-	-	-	-
LBA Low	Current	V	V	V	V	V	V	V	LBA Low	HOB=0	V	V	V	V	V	V	V
	Previous	V	V	V	V	V	V	V	HOB=1	V	V	V	V	V	V	V	V
LBA Mid	Current	V	V	V	V	V	V	V	LBA Mid	HOB=0	V	V	V	V	V	V	V
	Previous	V	V	V	V	V	V	V	HOB=1	V	V	V	V	V	V	V	V
LBA High	Current	V	V	V	V	V	V	V	LBA High	HOB=0	V	V	V	V	V	V	V
	Previous	V	V	V	V	V	V	V	HOB=1	V	V	V	V	V	V	V	V
Device	-	1	-	-	-	-	-	-	Device	-	-	-	-	-	-	-	-
Command	0	0	1	1	0	1	0	1	Status	...See Below...							

Error Register								Status Register							
7	6	5	4	3	2	1	0	7	6	5	4	3	2	1	0
CRC	UNC	0	IDN	0	ABT	TON	AMN	BSY	RDY	DF	DSC	DRQ	COR	IDX	ERR
V	0	0	V	0	V	0	0	0	V	0	V	-	0	0	V

Table 132 Write DMA Ext Command (35h)

The Write DMA Ext command transfers one or more sectors of data from the host to the device, then the data is written to the disk media.

The sectors of data are transferred through the Data Register 16 bits at a time.

The host initializes a slave-DMA channel prior to issuing the command. Data transfers are qualified by DMARQ and are performed by the slave-DMA channel. The device issues only one interrupt per command to indicate that data transfer has terminated and status is available.

If an uncorrectable error occurs, the write will be terminated at the failing sector

Output Parameters To The Device

Sector Count Current The number of continuous sectors to be transferred low order, bits (7:0).

Sector Count Previous The number of continuous sectors to be transferred high order bits (15:8). If 0000h in the Sector Count register is specified, then 65,536 sectors will be transferred.

LBA Low Current LBA (7:0).

LBA Low Previous LBA (31:24).

LBA Mid Current LBA (15:8).

LBA Mid Previous LBA (39:32).

LBA High Current LBA (23:16).

LBA High Previous LBA (47:40).

Input Parameters From The Device

LBA Low (HOB=0) LBA (7:0) of the address of the first unrecoverable error.

LBA Low (HOB=1) LBA (31:24) of the address of the first unrecoverable error.

LBA Mid (HOB=0) LBA (15:8) of the address of the first unrecoverable error.

LBA Mid (HOB=1) LBA (39:32) of the address of the first unrecoverable error.

LBA High (HOB=0) LBA (23:16) of the address of the first unrecoverable error.

LBA High (HOB=1) LBA (47:40) of the address of the first unrecoverable error.

14.47 Write DMA FUA Ext (3Dh)

Command Block Output Registers								Command Block Input Registers									
Register	7	6	5	4	3	2	1	0	Register	7	6	5	4	3	2	1	0
Data Low	-	-	-	-	-	-	-	-	Data Low	-	-	-	-	-	-	-	-
Data High	-	-	-	-	-	-	-	-	Data High	-	-	-	-	-	-	-	-
Feature	Current	-	-	-	-	-	-	-	Error	...See Below...							
	Previous	-	-	-	-	-	-	-									
Sector Count	Current	V	V	V	V	V	V	V	Sector Count	HOB=0	-	-	-	-	-	-	-
	Previous	V	V	V	V	V	V	V	HOB=1	-	-	-	-	-	-	-	-
LBA Low	Current	V	V	V	V	V	V	V	LBA Low	HOB=0	V	V	V	V	V	V	V
	Previous	V	V	V	V	V	V	V	HOB=1	V	V	V	V	V	V	V	V
LBA Mid	Current	V	V	V	V	V	V	V	LBA Mid	HOB=0	V	V	V	V	V	V	V
	Previous	V	V	V	V	V	V	V	HOB=1	V	V	V	V	V	V	V	V
LBA High	Current	V	V	V	V	V	V	V	LBA High	HOB=0	V	V	V	V	V	V	V
	Previous	V	V	V	V	V	V	V	HOB=1	V	V	V	V	V	V	V	V
Device	-	1	-	-	-	-	-	-	Device	-	-	-	-	-	-	-	-
Command	0	0	1	1	1	1	0	1	Status	...See Below...							

Error Register								Status Register							
7	6	5	4	3	2	1	0	7	6	5	4	3	2	1	0
CRC	UNC	0	IDN	0	ABT	TON	AMN	BSY	RDY	DF	DSC	DRQ	COR	IDX	ERR
V	0	0	V	0	V	0	0	0	V	0	V	-	0	0	V

Table 133 Write DMA FUA Ext Command (3Dh)

The Write DMA FUA Ext command transfers one or more sectors of data from the host to the device, then the data is written to the disk media. This command provides the same function as the Write DMA Ext command except that the transferred data shall be written to the media before the ending status for this command is reported also when write caching is enabled.

The sectors of data are transferred through the Data Register 16 bits at a time.

The host initializes a slave-DMA channel prior to issuing the command. Data transfers are qualified by DMARQ and are performed by the slave-DMA channel. The device issues only one interrupt per command to indicate that data transfer has terminated and status is available.

If an uncorrectable error occurs, the write will be terminated at the failing sector

Output Parameters To The Device

Sector Count Current	The number of continuous sectors to be transferred low order, bits (7:0).
Sector Count Previous	The number of continuous sectors to be transferred high order bits (15:8). If 0000h in the Sector Count register is specified, then 65,536 sectors will be transferred.
LBA Low Current	LBA (7:0).
LBA Low Previous	LBA (31:24).
LBA Mid Current	LBA (15:8).
LBA Mid Previous	LBA (39:32).
LBA High Current	LBA (23:16).
LBA High Previous	LBA (47:40).

Input Parameters From The Device

LBA Low (HOB=0)	LBA (7:0) of the address of the first unrecoverable error.
LBA Low (HOB=1)	LBA (31:24) of the address of the first unrecoverable error.
LBA Mid (HOB=0)	LBA (15:8) of the address of the first unrecoverable error.
LBA Mid (HOB=1)	LBA (39:32) of the address of the first unrecoverable error.
LBA High (HOB=0)	LBA (23:16) of the address of the first unrecoverable error.
LBA High (HOB=1)	LBA (47:40) of the address of the first unrecoverable error.

14.48 Write FPDMA Queued (61h)

Command Block Output Registers									Command Block Input Registers								
Register	7	6	5	4	3	2	1	0	Register	7	6	5	4	3	2	1	0
Data Low	-	-	-	-	-	-	-	-	Data Low	-	-	-	-	-	-	-	-
Data High	-	-	-	-	-	-	-	-	Data High	-	-	-	-	-	-	-	-
Feature	Current	V	V	V	V	V	V	V	Error	...See Below...							
	Previous	V	V	V	V	V	V	V									
Sector Count	Current	T	T	T	T	T	-	-	Sector Count	HOB=0	-	-	-	-	-	-	-
	Previous	P	-	-	-	-	-	-		HOB=1	-	-	-	-	-	-	-
LBA Low	Current	V	V	V	V	V	V	V	LBA Low	HOB=0	V	V	V	V	V	V	V
	Previous	V	V	V	V	V	V	V		HOB=1	V	V	V	V	V	V	V
LBA Mid	Current	V	V	V	V	V	V	V	LBA Mid	HOB=0	V	V	V	V	V	V	V
	Previous	V	V	V	V	V	V	V		HOB=1	V	V	V	V	V	V	V
LBA High	Current	V	V	V	V	V	V	V	LBA High	HOB=0	V	V	V	V	V	V	V
	Previous	V	V	V	V	V	V	V		HOB=1	V	V	V	V	V	V	V
Device	F	1	-	-	-	-	-	-	Device	-	-	-	-	-	-	-	-
Command	0	1	1	0	0	0	0	1	Status	...See Below...							

Error Register								Status Register							
7	6	5	4	3	2	1	0	7	6	5	4	3	2	1	0
CRC	UNC	0	IDN	0	ABT	TON	AMN	BSY	RDY	DF	DSC	DRQ	COR	IDX	ERR
V	0	0	V	0	V	0	0	0	V	0	V	-	0	0	V

Table 134 Write FPDMA Queued Command (61h)

The Write FPDMA Queued command transfers one or more sectors of data from the host to the device, then the data is written to the disk media.

If an uncorrectable error occurs, the write will be terminated at the failing sector

Output Parameters To The Device

- Feature Current** The number of sectors to be transferred low order, bit (7:0)
- Feature Previous** The number of sectors to be transferred high order, bit (15:8)
- T** TAG value. It shall be assigned to be different from all other queued commands. The value shall not exceed the maximum queue depth specified by the Word 75 of the Identify Device information.
- LBA Low Current** LBA (7:0).
- LBA Low Previous** LBA (31:24).
- LBA Mid Current** LBA (15:8).
- LBA Mid Previous** LBA (39:32).
- LBA High Current** LBA (23:16).
- LBA High Previous** LBA (47:40).
- F** FUA bit. When the FUA bit is set to 1, the completion status is indicated after the transferred data are written to the media also when Write Cache is enabled. When the FUA bit is set to 0, the completion status may be indicated before the transferred data are written to the media successfully when Write Cache is enabled.
- P** Priority bit. When the Priority bit is set to 1, the device attempts to provide better quality of service for the command than normal priority commands.

Input Parameters From The Device

- LBA Low (HOB=0)** LBA (7:0) of the address of the first unrecoverable error.
- LBA Low (HOB=1)** LBA (31:24) of the address of the first unrecoverable error.
- LBA Mid (HOB=0)** LBA (15:8) of the address of the first unrecoverable error.
- LBA Mid (HOB=1)** LBA (39:32) of the address of the first unrecoverable error.
- LBA High (HOB=0)** LBA (23:16) of the address of the first unrecoverable error.
- LBA High (HOB=1)** LBA (47:40) of the address of the first unrecoverable error.

14.49 Write Log Ext (3Fh)

Command Block Output Registers								Command Block Input Registers											
Register		7	6	5	4	3	2	1	0	Register		7	6	5	4	3	2	1	0
Data Low		-	-	-	-	-	-	-	-	Data Low		-	-	-	-	-	-	-	-
Data High		-	-	-	-	-	-	-	-	Data High		-	-	-	-	-	-	-	-
Feature	Current	-	-	-	-	-	-	-	-	Error		...See Below...							
	Previous	-	-	-	-	-	-	-	-										
Sector Count	Current	V	V	V	V	V	V	V	V	Sector Count	HOB=0	-	-	-	-	-	-	-	-
	Previous	V	V	V	V	V	V	V	V		HOB=1	-	-	-	-	-	-	-	-
LBA Low	Current	V	V	V	V	V	V	V	V	LBA Low	HOB=0	-	-	-	-	-	-	-	-
	Previous	-	-	-	-	-	-	-	-		HOB=1	-	-	-	-	-	-	-	-
LBA Mid	Current	V	V	V	V	V	V	V	V	LBA Mid	HOB=0	-	-	-	-	-	-	-	-
	Previous	V	V	V	V	V	V	V	V		HOB=1	-	-	-	-	-	-	-	-
LBA High	Current	-	-	-	-	-	-	-	-	LBA High	HOB=0	-	-	-	-	-	-	-	-
	Previous	-	-	-	-	-	-	-	-		HOB=1	-	-	-	-	-	-	-	-
Device		-	-	-	-	-	-	-	-	Device		-	-	-	-	-	-	-	-
Command		0	0	1	1	1	1	1	1	Status		...See Below...							
Error Register								Status Register											
7	6	5	4	3	2	1	0	7	6	5	4	3	2	1	0				
CRC	UNC	0	IDN	0	ABT	T0N	AMN	BSY	RDY	DF	DSC	DRQ	COR	IDX	ERR				
V	V	0	V	0	V	0	0	0	V	0	V	-	0	0	V				

Table 135 Write Log Ext Command

This command writes a specified number of 512 byte data sectors to the specific log. The device shall interrupt for each DRQ block transferred.

Output Parameters To The Device

Sector Count Current The number of sectors to be written to the specified log low order, bits (7:0).

Sector Count Previous The number of sectors to be written to the specified log high order, bits (15:8). If the number of sectors is greater than the number indicated in the Log directory, which is available in Log number zero, the device shall return command aborted. The log transferred to the device shall be stored by the device starting at the first sector in the specified log.

Sector Number Current The log to be written as described in Table 114 Log sector addresses definition. If the host attempts to write to a read only log address, the device shall return command aborted.

Cylinder Low Current The first sector of the log to be written low order, bits (7:0).

Cylinder Low Previous The first sector of the log to be written high order, bits (15:8)

If the feature set associated with the log specified in the Sector Number register is not supported or enabled, or if the values in the Sector Count, Sector Number or Cylinder Low registers are invalid, the device shall return command aborted. If the host attempts to write to a read only log address, the device shall return command aborted.

14.50 Write Log DMA Ext (57h)

Command Block Output Registers									Command Block Input Registers										
Register		7	6	5	4	3	2	1	0	Register		7	6	5	4	3	2	1	0
Data Low		-	-	-	-	-	-	-	-	Data Low		-	-	-	-	-	-	-	-
Data High		-	-	-	-	-	-	-	-	Data High		-	-	-	-	-	-	-	-
Feature	Current	-	-	-	-	-	-	-	-	Error		...See Below...							
	Previous	-	-	-	-	-	-	-	-										
Sector Count	Current	V	V	V	V	V	V	V	V	Sector Count	HOB=0	-	-	-	-	-	-	-	-
	Previous	V	V	V	V	V	V	V	V		HOB=1	-	-	-	-	-	-	-	-
LBA Low	Current	V	V	V	V	V	V	V	V	LBA Low	HOB=0	-	-	-	-	-	-	-	-
	Previous	-	-	-	-	-	-	-	-		HOB=1	-	-	-	-	-	-	-	-
LBA Mid	Current	V	V	V	V	V	V	V	V	LBA Mid	HOB=0	-	-	-	-	-	-	-	-
	Previous	V	V	V	V	V	V	V	V		HOB=1	-	-	-	-	-	-	-	-
LBA High	Current	-	-	-	-	-	-	-	-	LBA High	HOB=0	-	-	-	-	-	-	-	-
	Previous	-	-	-	-	-	-	-	-		HOB=1	-	-	-	-	-	-	-	-
Device		-	-	-	-	-	-	-	-	Device		-	-	-	-	-	-	-	-
Command		0	1	0	1	0	1	1	1	Status		...See Below...							
Error Register									Status Register										
7	6	5	4	3	2	1	0		7	6	5	4	3	2	1	0			
CRC	UNC	0	IDN	0	ABT	TON	AMN		BSY	RDY	DF	DSC	DRQ	COR	IDX	ERR			
V	V	0	V	0	V	0	0		0	V	0	V	-	0	0	V			

Table 136 Write Log DMA Ext Command

The content of this command is the same as Write Log Ext. See 14.49 .14.49 .

14.51 Write Multiple (C5h)

Command Block Output Registers								Command Block Input Registers									
Register	7	6	5	4	3	2	1	0	Register	7	6	5	4	3	2	1	0
Data	-	-	-	-	-	-	-	-	Data	-	-	-	-	-	-	-	-
Feature	-	-	-	-	-	-	-	-	Error	...See Below...							
Sector Count	V	V	V	V	V	V	V	V	Sector Count	V	V	V	V	V	V	V	V
LBA Low	V	V	V	V	V	V	V	V	LBA Low	V	V	V	V	V	V	V	V
LBA Mid	V	V	V	V	V	V	V	V	LBA Mid	V	V	V	V	V	V	V	V
LBA High	V	V	V	V	V	V	V	V	LBA High	V	V	V	V	V	V	V	V
Device	-	L	-	-	H	H	H	H	Device	-	-	-	-	H	H	H	H
Command	1	1	0	0	0	1	0	1	Status	...See Below...							

Error Register								Status Register							
7	6	5	4	3	2	1	0	7	6	5	4	3	2	1	0
CRC	UNC	0	IDN	0	ABT	T0N	AMN	BSY	RDY	DF	DSC	DRQ	COR	IDX	ERR
0	0	0	V	0	V	0	0	0	V	V	V	-	0	0	V

Table 137 Write Multiple Command (C5h)

The Write Multiple command transfers one or more sectors from the host to the device, then the data is written to the disk media.

Command execution is identical to the Write Sectors command except that an interrupt is generated for each block (as defined by the Set Multiple command) instead of for each sector. The sectors are transferred through the Data Register 16 bits at a time.

Output Parameters To The Device

Sector Count The number of continuous sectors to be transferred. If zero is specified, then 256 sectors will be transferred.

LBA Low The sector number of the first sector to be transferred. (L=0)
In LBA mode, this register contains LBA bits 0 - 7. (L=1)

LBA High/Mid The cylinder number of the first sector to be transferred. (L=0)
In LBA mode, this register contains LBA bits 8 - 15 (Mid), 16 - 23 (High). (L=1)

H The head number of the first sector to be transferred. (L=0)
In LBA mode, this register contains LBA bits 24 - 27. (L=1)

Input Parameters From The Device

Sector Count The number of requested sectors not transferred. This will be zero, unless an unrecoverable error occurs.

LBA Low The sector number of the last transferred sector. (L=0)
In LBA mode, this register contains current LBA bits 0 - 7. (L=1)

LBA High/Mid The cylinder number of the last transferred sector. (L=0)
In LBA mode, this register contains current LBA bits 8 - 15 (Mid), 16 - 23 (High). (L=1)

H The head number of the last transferred sector. (L=0)
In LBA mode, this register contains current LBA bits 24 - 27. (L=1)

14.52 Write Multiple Ext (39h)

Command Block Output Registers									Command Block Input Registers										
Register		7	6	5	4	3	2	1	0	Register		7	6	5	4	3	2	1	0
Data Low		-	-	-	-	-	-	-	-	Data Low		-	-	-	-	-	-	-	-
Data High		-	-	-	-	-	-	-	-	Data High		-	-	-	-	-	-	-	-
Feature	Current	-	-	-	-	-	-	-	-	Error		...See Below...							
	Previous	-	-	-	-	-	-	-	-										
Sector Count	Current	V	V	V	V	V	V	V	V	Sector Count	HOB=0	-	-	-	-	-	-	-	-
	Previous	V	V	V	V	V	V	V	V		HOB=1	-	-	-	-	-	-	-	-
LBA Low	Current	V	V	V	V	V	V	V	V	LBA Low	HOB=0	V	V	V	V	V	V	V	V
	Previous	V	V	V	V	V	V	V	V		HOB=1	V	V	V	V	V	V	V	V
LBA Mid	Current	V	V	V	V	V	V	V	V	LBA Mid	HOB=0	V	V	V	V	V	V	V	V
	Previous	V	V	V	V	V	V	V	V		HOB=1	V	V	V	V	V	V	V	V
LBA High	Current	V	V	V	V	V	V	V	V	LBA High	HOB=0	V	V	V	V	V	V	V	V
	Previous	V	V	V	V	V	V	V	V		HOB=1	V	V	V	V	V	V	V	V
Device		-	1	-	-	-	-	-	-	Device		-	-	-	-	-	-	-	-
Command		0	0	1	1	1	0	0	1	Status		...See Below...							

Error Register								Status Register							
7	6	5	4	3	2	1	0	7	6	5	4	3	2	1	0
CRC	UNC	0	IDN	0	ABT	TON	AMN	BSY	RDY	DF	DSC	DRQ	COR	IDX	ERR
0	0	0	V	0	V	0	0	0	V	0	V	-	0	0	V

Table 138 Write Multiple Ext Command (39h)

The Write Multiple Ext command transfers one or more sectors from the host to the device, then the data is written to the disk media.

Command execution is identical to the Write Sector(s) Ext command except that an interrupt is generated for each block (as defined by the Set Multiple command) instead of for each sector. The sectors are transferred through the Data Register 16 bits at a time.

Output Parameters To The Device

Sector Count Current The number of continuous sectors to be transferred low order, bits (7:0)

Sector Count Previous The number of continuous sectors to be transferred high order, bits (15:8). If 0000h in the Sector Count register is specified, then 65,536 sectors shall be transferred.

LBA Low Current LBA (7:0).

LBA Low Previous LBA (31:24).

LBA Mid Current LBA (15:8).

LBA Mid Previous LBA (39:32).

LBA High Current LBA (23:16).

LBA High Previous LBA (47:40).

Input Parameters From The Device

LBA Low (HOB=0) LBA (7:0) of the address of the first unrecoverable error.

LBA Low (HOB=1) LBA (31:24) of the address of the first unrecoverable error.

LBA Mid (HOB=0) LBA (15:8) of the address of the first unrecoverable error.

LBA Mid (HOB=1) LBA (39:32) of the address of the first unrecoverable error.

LBA High (HOB=0) LBA (23:16) of the address of the first unrecoverable error.

LBA High (HOB=1) LBA (47:40) of the address of the first unrecoverable error.

14.53 Write Multiple FUA Ext (CEh)

Command Block Output Registers								Command Block Input Registers									
Register	7	6	5	4	3	2	1	0	Register	7	6	5	4	3	2	1	0
Data Low	-	-	-	-	-	-	-	-	Data Low	-	-	-	-	-	-	-	-
Data High	-	-	-	-	-	-	-	-	Data High	-	-	-	-	-	-	-	-
Feature	Current	-	-	-	-	-	-	-	Error	...See Below...							
	Previous	-	-	-	-	-	-	-									
Sector Count	Current	V	V	V	V	V	V	V	Sector Count	HOB=0	-	-	-	-	-	-	-
	Previous	V	V	V	V	V	V	V		HOB=1	-	-	-	-	-	-	-
LBA Low	Current	V	V	V	V	V	V	V	LBA Low	HOB=0	V	V	V	V	V	V	V
	Previous	V	V	V	V	V	V	V		HOB=1	V	V	V	V	V	V	V
LBA Mid	Current	V	V	V	V	V	V	V	LBA Mid	HOB=0	V	V	V	V	V	V	V
	Previous	V	V	V	V	V	V	V		HOB=1	V	V	V	V	V	V	V
LBA High	Current	V	V	V	V	V	V	V	LBA High	HOB=0	V	V	V	V	V	V	V
	Previous	V	V	V	V	V	V	V		HOB=1	V	V	V	V	V	V	V
Device	-	1	-	-	-	-	-	-	Device	-	-	-	-	-	-	-	-
Command	1	1	0	0	1	1	1	0	Status	...See Below...							

Error Register								Status Register							
7	6	5	4	3	2	1	0	7	6	5	4	3	2	1	0
CRC	UNC	0	IDN	0	ABT	TON	AMN	BSY	RDY	DF	DSC	DRQ	COR	IDX	ERR
0	0	0	V	0	V	0	0	0	V	0	V	-	0	0	V

Table 139 Write Multiple FUA Ext Command (CEh)

The Write Multiple FUA Ext command transfers one or more sectors from the host to the device, then the data is written to the disk media. This command provides the same function as the Write Multiple Ext command except that the transferred data shall be written to the media before the ending status for this command is reported also when write caching is enabled.

Output Parameters To The Device

Sector Count Current The number of continuous sectors to be transferred low order, bits (7:0)

Sector Count Previous The number of continuous sectors to be transferred high order, bits (15:8). If 0000h in the Sector Count register is specified, then 65,536 sectors shall be transferred.

LBA Low Current LBA (7:0).

LBA Low Previous LBA (31:24).

LBA Mid Current LBA (15:8).

LBA Mid Previous LBA (39:32).

LBA High Current LBA (23:16).

LBA High Previous LBA (47:40).

Input Parameters From The Device

LBA Low (HOB=0) LBA (7:0) of the address of the first unrecoverable error.

LBA Low (HOB=1) LBA (31:24) of the address of the first unrecoverable error.

LBA Mid (HOB=0) LBA (15:8) of the address of the first unrecoverable error.

LBA Mid (HOB=1) LBA (39:32) of the address of the first unrecoverable error.

LBA High (HOB=0) LBA (23:16) of the address of the first unrecoverable error.

LBA High (HOB=1) LBA (47:40) of the address of the first unrecoverable error.

14.54 Write Sector(s) (30h/31h)

Command Block Output Registers								Command Block Input Registers									
Register	7	6	5	4	3	2	1	0	Register	7	6	5	4	3	2	1	0
Data	-	-	-	-	-	-	-	-	Data	-	-	-	-	-	-	-	-
Feature	-	-	-	-	-	-	-	-	Error	...See Below...							
Sector Count	V	V	V	V	V	V	V	V	Sector Count	V	V	V	V	V	V	V	V
LBA Low	V	V	V	V	V	V	V	V	LBA Low	V	V	V	V	V	V	V	V
LBA Mid	V	V	V	V	V	V	V	V	LBA Mid	V	V	V	V	V	V	V	V
LBA High	V	V	V	V	V	V	V	V	LBA High	V	V	V	V	V	V	V	V
Device	-	L	-	-	H	H	H	H	Device	-	-	-	-	H	H	H	H
Command	0	0	1	1	0	0	0	R	Status	...See Below...							

Error Register								Status Register							
7	6	5	4	3	2	1	0	7	6	5	4	3	2	1	0
CRC	UNC	0	IDN	0	ABT	T0N	AMN	BSY	RDY	DF	DSC	DRQ	COR	IDX	ERR
0	0	0	V	0	V	0	0	0	V	V	V	-	0	0	V

Table 140 Write Sector(s) Command (30h/31h)

The Write Sector(s) command transfers one or more sectors from the host to the device, then the data is written to the disk media.

The sectors are transferred through the Data Register 16 bits at a time.

If an uncorrectable error occurs, the write will be terminated at the failing sector, when the auto reassign function is disable.

Output Parameters To The Device

Sector Count The number of continuous sectors to be transferred. If zero is specified, then 256 sectors will be transferred.

LBA Low The sector number of the first sector to be transferred. (L=0)

In LBA mode, this register contains LBA bits 0 - 7. (L=1)

LBA High/Mid The cylinder number of the first sector to be transferred. (L=0)

In LBA mode, this register contains LBA bits 8 - 15 (Mid), 16 - 23 (High). (L=1)

H The head number of the first sector to be transferred. (L=0)

In LBA mode, this register contains LBA bits 24 - 27. (L=1)

R The retry bit, but this bit is ignored.

Input Parameters From The Device

Sector Count The number of requested sectors not transferred. This will be zero, unless an unrecoverable error occurs.

LBA Low The sector number of the last transferred sector. (L=0)

In LBA mode, this register contains current LBA bits 0 - 7. (L=1)

LBA High/Mid The cylinder number of the last transferred sector. (L=0)

In LBA mode, this register contains current LBA bits 8 - 15 (Mid), 16 - 23 (High). (L=1)

H The head number of the last transferred sector. (L=0) In LBA mode, this register contains current LBA bits 24 - 27. (L=1)

14.55 Write Sector(s) Ext (34h)

Command Block Output Registers								Command Block Input Registers									
Register	7	6	5	4	3	2	1	0	Register	7	6	5	4	3	2	1	0
Data Low	-	-	-	-	-	-	-	-	Data Low	-	-	-	-	-	-	-	-
Data High	-	-	-	-	-	-	-	-	Data High	-	-	-	-	-	-	-	-
Feature	Current	-	-	-	-	-	-	-	Error	...See Below...							
	Previous	-	-	-	-	-	-	-									
Sector Count	Current	V	V	V	V	V	V	V	Sector Count	HOB=0	-	-	-	-	-	-	-
	Previous	V	V	V	V	V	V	V		HOB=1	-	-	-	-	-	-	-
LBA Low	Current	V	V	V	V	V	V	V	LBA Low	HOB=0	V	V	V	V	V	V	V
	Previous	V	V	V	V	V	V	V		HOB=1	V	V	V	V	V	V	V
LBA Mid	Current	V	V	V	V	V	V	V	LBA Mid	HOB=0	V	V	V	V	V	V	V
	Previous	V	V	V	V	V	V	V		HOB=1	V	V	V	V	V	V	V
LBA High	Current	V	V	V	V	V	V	V	LBA High	HOB=0	V	V	V	V	V	V	V
	Previous	V	V	V	V	V	V	V		HOB=1	V	V	V	V	V	V	V
Device	-	1	-	-	-	-	-	-	Device	-	-	-	-	-	-	-	-
Command	0	0	1	1	0	1	0	0	Status	...See Below...							

Error Register								Status Register							
7	6	5	4	3	2	1	0	7	6	5	4	3	2	1	0
CRC	UNC	0	IDN	0	ABT	TON	AMN	BSY	RDY	DF	DSC	DRQ	COR	IDX	ERR
0	0	0	V	0	V	0	0	0	V	0	V	-	0	0	V

Table 141 Write Sector(s) Ext Command (34h)

The Write Sector(s) Ext command transfers one or more sectors from the host to the device, then the data is written to the disk media.

The sectors are transferred through the Data Register 16 bits at a time.

If an uncorrectable error occurs, the write will be terminated at the failing sector.

Output Parameters To The Device

Sector Count Current The number of continuous sectors to be transferred low order, bits (7:0).

Sector Count Previous The number of continuous sectors to be transferred high order bits (15:8). If 0000h in the Sector Count register is specified, then 65,536 sectors will be transferred.

LBA Low Current LBA (7:0).

LBA Low Previous LBA (31:24).

LBA Mid Current LBA (15:8).

LBA Mid Previous LBA (39:32).

LBA High Current LBA (23:16).

LBA High Previous LBA (47:40).

Input Parameters From The Device

LBA Low (HOB=0) LBA (7:0) of the address of the first unrecoverable error.

LBA Low (HOB=1) LBA (31:24) of the address of the first unrecoverable error.

LBA Mid (HOB=0) LBA (15:8) of the address of the first unrecoverable error.

LBA Mid (HOB=1) LBA (39:32) of the address of the first unrecoverable error.

LBA High (HOB=0) LBA (23:16) of the address of the first unrecoverable error.

LBA High (HOB=1) LBA (47:40) of the address of the first unrecoverable error.

14.56 Write Uncorrectable Ext (45h)

Command Block Output Registers									Command Block Input Registers								
Register	7	6	5	4	3	2	1	0	Register	7	6	5	4	3	2	1	0
Data Low	-	-	-	-	-	-	-	-	Data Low	-	-	-	-	-	-	-	-
Data High	-	-	-	-	-	-	-	-	Data High	-	-	-	-	-	-	-	-
Feature	Current	V	V	V	V	V	V	V	Error	...See Below...							
	Previous	-	-	-	-	-	-	-									
Sector Count	Current	V	V	V	V	V	V	V	Sector Count	HOB=0	-	-	-	-	-	-	-
	Previous	V	V	V	V	V	V	V		HOB=1	-	-	-	-	-	-	-
LBA Low	Current	V	V	V	V	V	V	V	LBA Low	HOB=0	V	V	V	V	V	V	V
	Previous	V	V	V	V	V	V	V		HOB=1	V	V	V	V	V	V	V
LBA Mid	Current	V	V	V	V	V	V	V	LBA Mid	HOB=0	V	V	V	V	V	V	V
	Previous	V	V	V	V	V	V	V		HOB=1	V	V	V	V	V	V	V
LBA High	Current	V	V	V	V	V	V	V	LBA High	HOB=0	V	V	V	V	V	V	V
	Previous	V	V	V	V	V	V	V		HOB=1	V	V	V	V	V	V	V
Device	-	1	-	-	-	-	-	-	Device	-	-	-	-	-	-	-	-
Command	0	1	0	0	0	1	0	1	Status	...See Below...							

Error Register								Status Register							
7	6	5	4	3	2	1	0	7	6	5	4	3	2	1	0
CRC	UNC	0	IDN	0	ABT	TON	AMN	BSY	RDY	DF	DSC	DRQ	COR	IDX	ERR
0	0	0	V	0	V	0	0	0	V	0	V	-	0	0	V

Table 142 Write Uncorrectable Ext Command (45h)

The Write Uncorrectable Ext command is used to cause the device to report an uncorrectable error when the target sector is subsequently read. As the logical sector is part of a larger (4KB) physical sector, then all the logical sectors within the same physical sector may report uncorrectable errors. When the Feature field (7:0) contains a value of 55h the Write Uncorrectable Ext command causes the device to indicate a failure when reads to any of the sectors that are contained in the physical block of the specified sector are performed. These sectors are referred to as “pseudo uncorrectable” sectors. In this case whenever a pseudo uncorrectable sector is accessed via a read command, the device performs normal error recovery and then set the UNC and ERR bits to indicate the sector is bad.

When the feature field contains a value of AAh, the Write Uncorrectable Ext command causes the device to flag the specified sector as “flagged uncorrectable”. Flagging a logical sector as uncorrectable causes the device to indicate a failure when reads to specified sectors are performed. These sectors are referred to as “flagged uncorrectable” sectors. In this case whenever a “flagged uncorrectable” sector is accessed via a read command, the device sets the UNC and ERR bits without normal error recovery to indicate the sector is bad.

If the Uncorrectable options are set to 55h, then sectors that have been made pseudo uncorrectable are listed as failed in the standard error logs when read back. If the Uncorrectable options are set to AAh, then the reading of flagged uncorrectable sectors are not logged as an error in any standardized error logs.

The pseudo uncorrectable or flagged uncorrectable status of a sector remains through a power cycle.

If the device is unable to process a WRITE UNCORRECTABLE EXT command for any reason the device reports command aborted error.

Output Parameters To The Device

Feature Current

Uncorrectable options

55h : Create a pseudo uncorrectable error with logging

AAh: Create a flagged error without logging

Other: Reserved (command is aborted)

Sector Count Current

The number of continuous sectors to be marked low order, bits (7:0).

Sector Count Previous

The number of continuous sectors to be marked high order bits (15:8). If 0000h in the Sector Count register is specified, then 65,536 sectors will be transferred.

LBA Low Current

LBA (7:0).

LBA Low Previous

LBA (31:24).

LBA Mid Current

LBA (15:8).

LBA Mid Previous

LBA (39:32).

LBA High Current	LBA (23:16).
LBA High Previous	LBA (47:40).
Input Parameters From The Device	
LBA Low (HOB=0)	LBA (7:0) of the address of the first unrecoverable error.
LBA Low (HOB=1)	LBA (31:24) of the address of the first unrecoverable error.
LBA Mid (HOB=0)	LBA (15:8) of the address of the first unrecoverable error.
LBA Mid (HOB=1)	LBA (39:32) of the address of the first unrecoverable error.
LBA High (HOB=0)	LBA (23:16) of the address of the first unrecoverable error.
LBA High (HOB=1)	LBA (47:40) of the address of the first unrecoverable error.

15 Timings

The timing of BSY and DRQ in Status Register are shown in the following table. The other timings are described in Functional Specification part.

FUNCTION	INTERVAL	START	STOP	TIMEOUT
Power On and COMRESET	Device Ready After Power On	Power On and COMRESET	Status Register BSY=0 and RDY=1 and sends a Register FIS to the host.	31 sec
Software Reset	Device Busy After Software Reset	Device Control Register RST=1 and sends a Register FIS to the Device.	Status Register BSY=1	400 ns
	Device Ready After Software Reset	Device Control Register RST=0 and sends a Register FIS to the Device. After RST=1 and sends a Register FIS to the Device.	Status Register BSY=0 and RDY=1 and requests to send a Register FIS to the host.	31 sec
COMRESET	Device Ready After COMRESET	COMRESET Signal Asserted	Status Register BSY=0 and RDY=1 and sends a Register FIS to the Host.	31 sec
Data In Command	Device Busy After a Register FIS to issue a command	Sets proper values in the registers and sends a Register FIS	Status Register BSY=1	400 ns
	PIO SETUP FIS for data-in transfer	Status Register BSY=1	Status Register BSY=0 and DRQ=1 and sends a PIO SETUP FIS to the host.	30 sec
	Device Busy After Data Transfer In	A PIO SETUP FIS is transferred to the host.	Status Register BSY=1	10 us
Data Out Command	Device Busy After a Register FIS to issue a command	Sets proper values in the registers and sends a Register FIS	Status Register BSY=1	400 ns
	Device Busy After Data Transfer Out	Sends a Data FIS to the device.	Status Register BSY=1	5 us
	PIO SETUP FIS for data-out transfer	Status Register BSY=1	Status Register BSY=0 and RDY=1 and sends a PIO SETUP FIS to the host.	30 sec (Note.1)
Non-Data Command	Device Busy After a Register FIS to issue a command	Sets proper values in the registers and sends a Register FIS	Status Register BSY=1	400 ns
	A Register FIS to report Command Complete	Status Register BSY=1	Sets the status of the command to the Status Register and sends a Register FIS to the host	30 sec (Note.2)
DMA Data Transfer Command	Device Busy After a Register FIS to issue a command	Sets proper values in the registers and sends a Register FIS	Status Register BSY=1	400 ns

Table 143 Timeout Values

Command category is referred to “13 Command Protocol” on page 70.

The abbreviations “ns”, “us”, “ms” and “sec” mean nanoseconds, microseconds, milliseconds and seconds, respectively. We recommend that the host system executes Soft reset and then retry to issue the command if the host system timeout would occur for the device.

(Note.1) For SECURITY ERASE UNIT command, the execution time is referred to “14.30 Security Erase Unit (F4h)” on Page127.

(Note.2)

FORMAT UNIT command, the execution time is referred to “14.8 Format Unit (F7h: Vendor Specific)” on Page88.