



Technical Reference Manual

WD Purple[®] Pro PR26/PR24-1 Surveillance Hard Drives

WD260HKAI-78CNSY0
WD241HKAI-78CNSY0

© 2025 Western Digital Corporation or its affiliates
All Rights Reserved

Information furnished by Western Digital is believed to be accurate and reliable. No license is granted by implication or otherwise under any Western Digital patent or patent rights. Western Digital reserves the right to change specifications at any time without notice.

Pictures shown may vary from actual products.

Western Digital, the Western Digital design, the Western Digital logo, AllFrame, Data Lifeguard, NoTouch, Western Digital Device Analytics, and WD Purple are registered trademarks or trademarks of Western Digital Corporation or its affiliates in the US and/or other countries. All other marks are the property of their respective owners.

Western Digital
5601 Great Oaks Parkway
San Jose, CA 95119

D018-001050-000000 Rev 1.0

Document Control Number Definition:

D018-xxxxxx-xxxxxx	Revxx	NRD
Doc Control No.	Doc Revision Level	Non-Released Document
Released Version	Rev xx = Revision	

WD Purple[®] Pro PR26/PR24-1

Technical Reference Manual



TABLE OF CONTENTS

1.0	GENERAL DESCRIPTION.....	8
1.1	General Description.....	8
1.2	Product Features	8
2.0	SPECIFICATIONS.....	10
2.1	Performance Specifications	10
2.2	Physical Drive Specifications	10
2.2.1	Physical Dimensions.....	10
2.3	Mechanical Specifications	11
2.4	Electrical Specifications	12
2.4.1	Current Requirements and Power Dissipation	12
2.4.2	Input Voltage Requirements	12
2.4.3	Voltage Ripple	12
2.4.4	Power Connectors and Cables	13
2.5	Environmental Specifications	13
2.6	RoHS (Restriction of Hazardous Substances)	15
2.7	Reliability Specification and Characteristics	16
2.8	Agency Approvals	16
2.9	Full Model Number Specification	17
3.0	PRODUCT FEATURES	18
3.1	Western Digital's exclusive AllFrame™ AI Technology	19
3.2	Proactive storage management with WDDA	19
3.3	OptiNAND™ Technology	19
3.4	Triple Stage Actuator (TSA) Technology	19
3.5	Two-Dimensional Magnetic Recording (TDMR) Technology	19
3.6	Rotational Vibration Safeguard (RSV)	19
3.7	Premium Protection	19
3.8	SATA 6 Gb/s	19
3.9	Dynamic Fly Height Control.....	20
3.10	Energy-assisted PMR (ePMR).....	20
3.11	NoTouch™ Ramp Load Technology.....	20
3.12	Advanced Format (AF)	20
3.13	Native Command Queuing (NCQ).....	20
3.14	S.M.A.R.T. Command Transport (SCT)	21
3.15	World Wide Name (WWN)	21
3.16	Reliability Features Set	22
3.16.1	Thermal Management	22
3.16.2	Internal Environmental Protection System.....	22
3.16.3	Unrecoverable Errors	22
3.16.4	Self Test	22
3.16.5	ATA Error Logging	22
3.16.6	Defect Management	23
3.17	Automatic Defect Retirement	23
3.17.1	Error Recovery Process	23
3.18	Hot Plug Support	24
3.19	Active LED Status.....	24
3.20	Fluid Dynamic Bearings (FDB)	24
3.21	Staggered Spinup and Activity Indication (SATA Power Pin 11)	24
3.22	48-bit Logical Block Addressing (LBA)	25
3.23	Power Management.....	25
3.24	Self-Monitoring, Analysis, and Reporting Technology (S.M.A.R.T.)	25
3.25	Security Mode	26

Table of Contents

4.0	ATA COMMAND SET	27
4.1	Host Interface Commands.....	27
4.2	SCT Commands.....	28
4.3	S.M.A.R.T. (B0h).....	28
4.4	Identify Device (ECh).....	32
4.5	Set Features (EFh).....	40
5.0	INSTALLATION AND SETUP PROCEDURES	41
5.1	Unpacking.....	41
5.2	Hard Drive Installation.....	42
5.3	Mounting.....	42
5.4	Serial ATA Latching Connector.....	43
6.0	MAINTENANCE	44
7.0	TECHNICAL SUPPORT	45
7.1	WD Online Services.....	45
8.0	THIRD-PARTY NOTICES	46
8.1	bzip2.....	46
8.2	PCRE.....	47
9.0	GLOSARY	48
INDEX	Error! Bookmark not defined.	

LIST OF FIGURES

Figure 1 Mounting Dimensions..... 11

LIST OF TABLES

Table 1	Performance Specifications.....	10
Table 2	Physical Specifications	10
Table 3	Physical Dimensions.....	10
Table 4	Current Requirements and Power Dissipation	12
Table 5	Power Management Commands.....	12
Table 6	Input Voltage Requirements.....	12
Table 7	Voltage Ripple.....	12
Table 8	Shock and Vibration	13
Table 9	Temperature and Humidity.....	14
Table 10	Atmospheric Pressure.....	15
Table 11	Acoustics	15
Table 12	Reliability Specification and Characteristics.....	16
Table 13	Full Model Number Description	17
Table 14	48-bit Logical Block Addressing (LBA)	25
Table 15	ACS Command Opcodes.....	27
Table 16	ACS Command Opcodes (Continued).....	28
Table 19	SCT Action Codes	28
Table 20	Definitions for the 512 Bytes.....	29
Table 21	Read Attribute Values Sub-Command (Continued).....	30
Table 22	Supported Attributes	30
Table 23	Log Address Definition	31
Table 24	Identify Device Command	32
Table 25	Identify Device Command (Continued)	33
Table 26	Identify Device Command (Continued)	34
Table 27	Identify Device Command (Continued)	35
Table 28	Identify Device Command (Continued)	36
Table 29	Identify Device Command (Continued)	37
Table 30	Identify Device Command (Continued)	38
Table 31	Identify Device Command (Continued).....	39
Table 32	Set Features (EFh)	40

1.0 GENERAL DESCRIPTION

1.1 General Description

WD Purple® Pro drives are designed for new generations of high-end AI-enabled recorders, video analytics appliances, deep-learning servers and cloud solutions that can benefit from high-capacity storage with high performance and additional workload capability. WD Purple® Pro drives feature AllFrame™ AI technology, which helps reduce frame loss, improve overall video playback, and not only enables recording of multiple streams per camera but also supports up to 32 AI streams per drive for deep learning analytics within the system. WD Purple® Pro drives also feature enterprise-class performance, data integrity and drive reliability, especially in larger-scale systems and enclosures where operational vibration is present.

1.2 Product Features

- **Western Digital's exclusive AllFrame™ AI Technology** — All WD Purple® Pro drives are equipped with AllFrame AI technology, which not only improves ATA streaming to help reduce frame loss and improve overall video playback, but supports up to 32 AI streams for Deep Learning analytics within the system.
- **Proactive storage management with WDDA** — WD Purple® Pro drives support Western Digital® Device Analytics™ (WDDA), which provides a wealth of storage device parametric operational and diagnostic data to the system; algorithms interpret the data and direct the system to alert system administrators of specific recommended actions to address potential issues. WDDA is intended to empower OEMs, system integrators, and IT professionals to better monitor and proactively manage supported storage devices to maintain optimal operation.
- **OptiNAND™**: The WD Red® Pro 24 and 26TB¹ HDD is perfect for power users to medium-sized organizations with NAS systems used for archiving, sharing, and helping protect rapidly growing volumes of data.
- **Two-Dimensional Magnetic Recording (TDMR) Technology** — New technology which places two read heads onto each arm, thus allowing data tracks to be squeezed closer together, enabling higher areal density required for a 26TB capacity at 11 disks.
- **Rotational Vibration Safeguard (RSV)** — Maintains drive performance in high rotational vibration environments and multi-drive systems.
- **Energy-assisted PMR (ePMR)** — ePMR is the first implementation of EAMR new technology. It utilizes a bias current applied to the head to enhance writability.
- This technology gives Western Digital HDDs areal density leadership while maintaining the reliability & performance needed for data center workloads.
- **Triple Stage Actuator (TSA)** — New technology for improved performance and accurate head and arm positioning, especially in multi-drive environments, for better performance.
- **Premium Protection** — Designed with tarnish-resistant components, this WD Purple® Pro drive offers premium protection in harsh environments where surveillance systems may be installed.
- **Serial ATA (SATA)** — Serial ATA (SATA) is the industry standard bus interface for hard drives and has many advantages including increased transfer rate, improved signal integrity, enhanced data protection, and hot plug support.
- **Dynamic Fly Height Control** — Designed to compensate for head/media separation changes due to temperature and altitude. This feature adds video quality margins across temperature and altitude changes.

¹ 1TB = 1 trillion bytes. Actual user capacity may be less depending on operating environment.

- **NoTouch™ Ramp Load Technology** — The recording head never touches the disk media ensuring significantly less wear to the recording head and media as well as better drive protection in transit.
- **Advanced Format (AF)** — Technology adopted by WD and other drive manufacturers as one of multiple ways to continue growing hard drive capacities. AF is a more efficient media format that enables increased areal densities.
- **Native Command Queuing (NCQ)** — Performance of a random I/O workload can be improved through intelligent re-ordering of the I/O requests so they read/write to and from the nearest available sectors and minimize the need for additional disk revolutions or head actuator movement. This improvement can be achieved through Native Command Queuing (NCQ), which is supported by these hard drives.
- **S.M.A.R.T. Command Transport (SCT)** — The SCT Command Transport feature set provides a method for a host to send commands and data to a device and for a device to send data and status to a host using log pages.
- **World Wide Name (WWN)** — The World Wide Name (WWN) defined in ATA Command Set (ACS) is a modification of the IEEE extended unique identifier 64 bit standard (EUI-64) and is comprised of three major components: naming authority, organizationally unique identifier (OUI) and serial number. WD's OUI is 0014EEh.
- **Hot Plug Support** — SATA supports hot plugging (also known as "hot swapping"), the ability to swap out a failed hard drive without having to power down the system or reboot. This capability contributes to both data availability and serviceability without any associated downtime, making it a critical feature for extending SATA into enterprise applications.
- **Active LED Status** — The drive supports external LED requirements. It provides an activity LED output which is ON during command execution and OFF otherwise.
- **Fluid Dynamic Bearings (FDB)** — Bearing design that incorporates a layer of high-viscosity lubricant instead of ball bearings in the hard drive spindle motor. As an alternative to conventional ball bearing technology, FDB designs provide increased non-operational shock resistance, speed control, and improved acoustics.
- **S.M.A.R.T. Command Transport (SCT)** — The SCT Command Transport feature set provides a method for a host to send commands and data to a device and for a device to send data and status to a host using log pages.
- **48-bit Logical Block Addressing (LBA)** — WD SATA drives support both 48-bit and 28-bit LBA and CHS-based addressing. LBA is included in advanced BIOS and operating system device drivers and ensures high capacity disk integration.
- **Power Management** — The drive supports the ATA and SATA power management command set, allowing the host to reduce the power consumption of the drive by issuing a variety of power management commands.
- **Self-Monitoring, Analysis, and Reporting Technology (S.M.A.R.T.)** — S.M.A.R.T. enables a drive's internal status to be monitored through diagnostic commands at the host level and during offline activities. S.M.A.R.T. devices employ data analysis algorithms that are used to predict the likelihood of some near-term degradation or fault conditions. When used with a S.M.A.R.T. application, the drive can alert the host system of a negative reliability status condition. The host system can then warn the user of the impending risk of data loss and recommend an appropriate action.
- **ATA Security** — The drive supports the ATA Security Mode Feature set. The ATA Security Mode feature set allows the user to create a device lock password that prevents unauthorized hard disk access even if the drive is removed from the host computer. The correct password must be supplied to the hard drive in order to access user data. Both the User and Master Password features are supported, along with the High and Maximum security modes. The Master Password Revision code is also supported. This feature varies by drive configuration and may not be available on all configurations.

2.0 SPECIFICATIONS

2.1 Performance Specifications

Table 1 Performance Specifications

Rotational Speed	7200 RPM
Data Transfer Rate (maximum) ¹ - Buffer to Host - Host to/from Disk	6 Gb/s 287 MB/s sustained
Buffer Size	512 MB
Error Rate (non-recoverable bits read)	<1 in 10 ¹⁵
Spindle Start Time (average) - From Power-on to Drive Ready	25 s
Load/Unload Cycles (controlled unload at ambient condition)	600,000

¹ 1 MB/s = 1 million bytes per second. Based on internal testing; performance may vary depending upon host device, usage conditions, drive capacity, and other factors. Effective maximum SATA 6 Gb/s transfer rate calculated according to the Serial ATA specification published by the SATA-IO organization as of the date of this document. Visit www.sata-io.org details.

2.2 Physical Drive Specifications

Specifications represented are of a typical production drive and may be subject to change or variation without notice.

Table 2 Physical Specifications¹

Description	WD260HKAI	WD241HKAI
Capacity ¹	26TB	24TB
Interface	SATA 6 Gb/s	SATA 6 Gb/s
Number of Disks	11	11
Data Surfaces	22	22
Number of Heads	22	22
Physical Bytes Per Sector	4096	4096
Host Bytes Per Sector	512	512
User Sectors per Drive	50,782,535,680	46,875,541,504
Servo Type	Embedded	
Recording Method	LDPC-Low Density Parity Code	

¹ 1TB = 1 trillion bytes. Actual user capacity may be less depending on operating environment.

2.2.1 Physical Dimensions

Table 3 Physical Dimensions

	English		Metric	
	Dimension	Tolerance	Dimension	Tolerance
Height	1.028 inches	MAX	26.1 mm	MAX
Length	5.787 inches	MAX	147.0 mm	MAX
Width	4.00 inches	±0.01 inch	101.6 mm	±0.25 mm
Weight	1.48 pounds	MAX	0.670 kg	MAX

2.3 Mechanical Specifications

Figure 1 shows the mounting dimensions and locations of the screw holes for the drive.

Note: Unless otherwise specified, all measurements are in millimeters.

Figure 1 Mounting Dimensions

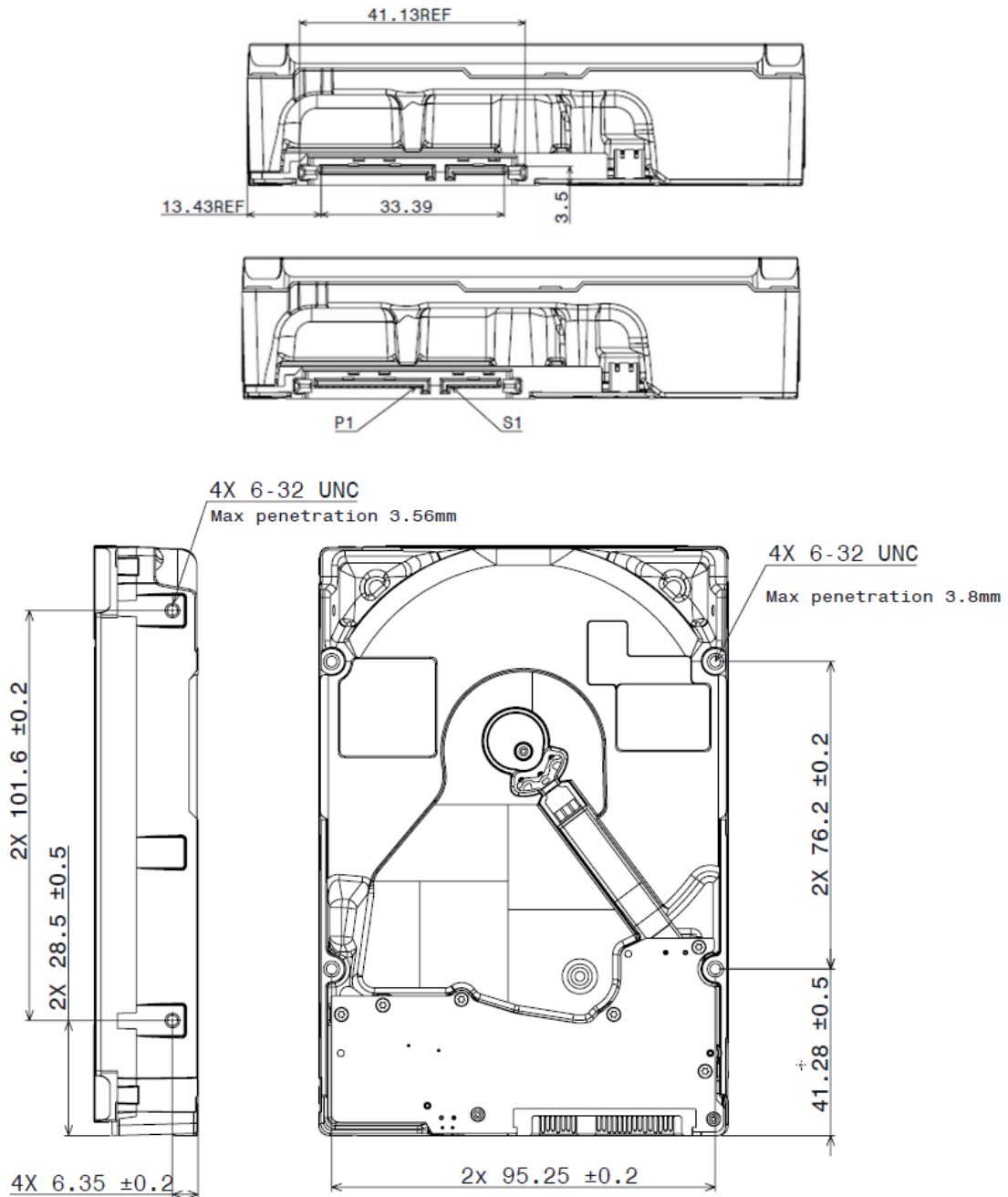

2.4 Electrical Specifications

2.4.1 Current Requirements and Power Dissipation

All values are typical (25°C, 5.0V, and 12V input). 3.3V Serial ATA power not utilized in this product.

Table 4 Current Requirements and Power Dissipation

Operating Mode	Mean Current		Power
	12 VDC	5 VDC	
Spinup (max)	2.0 A	-	
Read/Write (avg)	325 mA	460 mA	6.2 W

Table 5 Power Management Commands

POWER MANAGEMENT COMMANDS			
Operating Mode	Mean Current		Power, Average
	12 VDC	5 VDC	
Idle (avg)	335 mA	285 mA	5.7 W
Standby (avg)	10 mA	195 mA	1.1 W
Sleep (avg)	10 mA	195 mA	1.1 W

2.4.2 Input Voltage Requirements

The input voltage requirements are +5.0V \pm 5% and +12.0V \pm 10%.

Table 6 Input Voltage Requirements

Input Voltage	During run and spin up	Absolute Max Spike Voltage	Supply Rise Time
+5 Volts Supply	5V \pm 5%	-0.3 to 5.5V	0 to 200ms
+12 Volts Supply	12V \pm 5%	-0.3 to 15.0V	0 to 400ms

CAUTION: To avoid damage to the drive electronics, power supply voltage must not exceed specifications.

2.4.3 Voltage Ripple

Table 7 Voltage Ripple

	Maximum (mV pp)	MHz
+5V DC	200	0-10
+12V DC	250	0-10

2.4.4 Power Connectors and Cables

2.4.4.1 Serial ATA Connectors

For information on SATA data connectors, including the pin definitions of the SATA connectors and the corresponding signal names and signal functions, refer to the latest SATA specification available for download at www.serialata.org.

2.4.4.2 Cabling Requirements for Serial ATA

The SATA cable consists of four conductors in two differential pairs. The cable may also include drain wires to be terminated to the ground pins in the SATA cable receptacle connectors. See the SATA specification for cable specifications. The cable's maximum length is one meter.

It is recommended that customers use SATA cable receptacles with internal bumps to provide additional retention when mating with an enterprise hot-plug optimized hard drive connector.

2.5 Environmental Specifications

2.5.1 Shock and Vibration

Table 8 Shock and Vibration

Shock										
Operating (2ms)	40G									
Non-operating (2 ms)	200G									
<i>Note: Half-sine wave, measured without shock isolation and without non-recoverable errors.</i>										
Vibration										
Operating (linear)	Sine: 5-300 Hz, 1.0G (0 to peak) Random: 5-500 Hz, 0.67 Grms ¹									
Non-operating	Sine: 5-500 Hz, 2.0G (0 to peak) Random: 2-200 Hz, 1.04 Grms ²									
<i>Note: Sine vibration with sweep rate of 0.5 octave/minute.</i>										
¹Random Vibration (Operating)										
Frequency (Hz)	5	17	45	48	62	65	150	200	500	RMS
(m/sec ²) ² /Hz	0.0021	0.12	0.12	0.84	0.84	0.10	0.10	0.052	0.052	6.86 m/sec ² (0.69 G)
²Random Vibration (Non-Operating)										
Frequency (Hz)	2	4	8	40	55	70	200	RMS		
(m/sec ²) ² /Hz	0.096	2.89	2.89	0.289	0.962	0.962	0.096	10.2 m/sec ² (1.04 G)		
Rotational Vibration										
12.5 rad/sec ² based on the following PSD profile maintaining <20% degradation:										
Frequency	20	100	200	800	1000	1500	1700	2000	RMS	
[(Rad/s ²) ² /Hz]	0.019	0.019	0.187	0.187	0.053	0.008	0.004	0.004	12.5 (Rad/s ²)	
Drive A Generated Vibration										
Operating	0.2 gm-mm average with the drive in an unconstrained condition									
Rotational Shock Non-Operating										
Amplitude	20K rad/sec ²									
Duration	2 ms									

Operating Vibration

Drives are tested by applying a random excitation in each linear axis, one axis at a time. The drive incurs no physical damage and no hard errors while subjected to continuous vibration not exceeding the level listed in Table 8, "Shock and Vibration". Operating performance may degrade during periods of exposure to continuous vibration.

Non-Operating Vibration

Note: This specification applies to handling and transportation of unmounted drives.

Drives are tested by applying a random excitation in each linear axis, one axis at a time. The drive incurs no physical damage when subjected to continuous vibration not exceeding the level listed in the Table 8, "Shock and Vibration".

Packaged Shock and Vibration

The shipping packaging is designed to meet the National/International Safe Transit Association (N/ISTA) standards for packaged products. The drive incurs no physical damage when subjected to the N/ISTA standards.

2.5.2 Temperature and Humidity

The system environment must allow sufficient air flow to limit maximum drive temperatures as defined. Drive temperature is temperature reported via the S.M.A.R.T. Command Transport Temperature Reporting (SCTTR) feature. AFR can be affected by workload and operating temperature. See [Section 2.7 Reliability Specification and Characteristics](#) on page 16 or further details.

Table 9 Temperature and Humidity

Operation	
Min-Max Drive Temperature ¹	5°C to 65°C (41°F to 149°F)
Relative Humidity	5 to 95% non-condensing
Maximum Wet Bulb Temperature	29.4°C non-condensing
Maximum Temperature Gradient	20°C/Hour
Maximum Relative Humidity gradient	20%/Hour
Non-Operation	
Min-Max Drive Temperature	-40°C to 70°C (Storage 0 to 60°C)
Relative Humidity	5 to 95% non-condensing
Maximum Wet Bulb Temperature	35°C non-condensing
Maximum Temperature Gradient	20°C/Hour
Maximum Relative Humidity gradient	20%/Hour

¹Operating at elevated drive temperatures will result in higher AFR.

2.5.3 Cooling

If forced air cooling is required, the drive must be positioned to receive airflow from one or more fans.

2.5.4 Atmospheric Condition

Environments that contain elevated levels of corrosives (e.g., hydrogen sulfide, sulfur oxides, or hydrochloric acid, sulfurous gases, chlorine and nitric oxide) should be avoided and ideally kept below G2 severity level defined in ISA-71.04-1985. Care must be taken to avoid using any compound/material in a way that creates an elevated level of corrosive materials in the atmosphere surrounding the disk drive. Vulcanized rubber is an example of a material which may contain corrosive compound/materials.

Care must also be taken to avoid the use of any organometallic (e.g., organosilicones or organotins) compound/material in a way that creates elevated vapor levels of these compounds/materials in the atmosphere surrounding the disk drive.

Silicone-based Thermal Interface Materials (TIM), silicone-based tapes, caulking/RTV pastes, silicone rubbers and silicone oil lubricants are examples of materials which may create elevated vapor levels of organometallic compound/materials.

Use of the disk drive in these abnormal or other chemically-challenging environments is not recommended and increases the risk for failure. If any of these materials are considered in system design, it is recommended to consult with Western Digital Corporation.

2.5.5 Atmospheric Pressure

Table 10 Atmospheric Pressure

Altitude	
Operating	-1000 feet to 10,000 feet (-305 M to 3,050 M)
Non-operating	-1000 feet to 40,000 feet (-305 M to 12,200 M)

2.5.6 Acoustics

Table 11 Acoustics

TYPICAL SOUND POWER LEVEL Measured per ECMA-74/ISO 7779	
Idle Mode (average dBA, no audible pure tones)	25
Seek Mode (average dBA)	32

2.6 RoHS (Restriction of Hazardous Substances)

This hard drive product meets or exceeds Restriction of Hazardous Substances (RoHS) compliance requirements as mandated by the RoHS Directive 2011/65/EU and Directive (EU) 2015/863.

2.7 Reliability Specification and Characteristics

The Average Annualized Failure Rate (AFR) calculations assume operation at nominal voltages, a drive temperature of 40°C, and the workload usage of a typical surveillance environment.

Workload is defined as the number of bytes transferred by the user to/from the drive. If the system(s) that the drive is installed in are not capable of meeting the characteristics listed below, please use a WD drive that matches your system(s)' capability. Operating drives outside any of the reliability characteristics below will result in a higher AFR.

Table 12 Reliability Specification and Characteristics

Reliability Specification	
Average AFR over the Limited Warranty Period ¹	0.35%
Reliability Characteristics	
Drive Temperature	Up to 65°C
Annual Power on Hours (POH)	Up to 8760
Total Workload over the Limited Warranty Period ²	Up to 550TB/Yr

¹ Projected values. This product has a 0.35% AFR specification rating based on typical workload and temperatures. The AFR specification is based on a sample population and is estimated by statistical measurements and acceleration algorithms under typical operating conditions at a workload of 220TB/year and drive temperature of 40C. Derating of AFR and max rated workload will occur above these parameters. AFR ratings do not predict an individual drive's reliability and do not constitute a warranty.

² Annualized Workload Rate = TB transferred x (8760 / recorded power-on hours). The maximum rated workload is specified for operating at typical temperature of 40C. Workload Rate will vary depending on your hardware and software components and configurations.

2.8 Agency Approvals

PR16/PR24-1 Regulatory Number (R/N): US7SAU260

These drives meet the standards of the following regulatory agencies:

- **Federal Communication Commission:** Verified to comply with FCC Rules for Radiated and Conducted Emission, Part 15, Subpart B, for Class B Equipment.
- **Underwriters Laboratories:** Bi-National UL Standards of UL 62368-1 and CAN/CSA-C22.2 No. 62368-1-14 for Audio/video, information and communication technology equipment Part I: Safety requirements. (File E182115).
- **UL/CSA/EU Compliance:** IEC/EN 62368-1 and 2020+A1 60950-1 Safety Compliance for Information Technology Equipment, including Electrical Business Equipment.
- **CE Compliance for Europe Countries and Morocco:** Verified to comply with EN55032:2015 for RF Emissions and EN55035, EN61000-3-2, EN61000-3-3 for Generic Immunity as applicable.
- **RCM Compliance for Australia and New Zealand:** Verified to comply with AS/NZ3548 for RF Emissions as required by the Australian Communications Authority tested to EN55032.
- **Korean KC Mark:** Registered as a Class-B product with the Radio Research Agency of South Korean Ministry of Science and ICT.
- **Taiwan BSMI ROHS Compliance:** Certified as a Class-B product with the Bureau of Standards Metrology and Inspection (BSMI RoHS).

2.9 Full Model Number Specification

Table 13, provides a summary specification of the model number suffix for this product platform.

Table 13 Full Model Number Description

Model Number Format	ID	Product Brand	RPM	Description
WD260HKAI-78CNSY0	CNS	WD Purple® Pro	7200	PR26 26TB SVR 512MB SATA 6Gb/s AF
WD240HKAI-78CNSY0	CNS	WD Purple® Pro	7200	PR24-1 24TB SVR 512MB SATA 6Gb/s AF

3.0 PRODUCT FEATURES

- Western Digital's exclusive AllFrame™ AI Technology
- Proactive storage management with WDDA
- OptiNAND™ Technology
- Triple Stage Actuator (TSA) Technology
- Two-Dimensional Magnetic Recording (TDMR) Technology
- Rotational Vibration Safeguard (RSV)
- Premium Protection
- SATA 6 Gb/s
- Dynamic Fly Height Control
- Energy-assisted PMR (ePMR)
- NoTouch™ Ramp Load Technology
- Advanced Format (AF)
- Native Command Queuing (NCQ)
- S.M.A.R.T. Command Transport (SCT)
- World Wide Name (WWN)
- Reliability Features Set
- Automatic Defect Retirement
- Hot Plug Support
- Active LED Status
- Fluid Dynamic Bearings (FDB)
- Staggered Spin-Up and Activity Indication (SATA Power Pin 11)
- 48-bit Logical Block Addressing (LBA)
- Power Management
- Self-Monitoring, Analysis, and Reporting Technology (S.M.A.R.T.)
- Security Mode

3.1 Western Digital's exclusive AllFrame™ AI Technology

All WD Purple® Pro drives are equipped with AllFrame AI technology, which not only improves ATA streaming to help reduce frame loss and improve overall video playback, but supports up to 32 AI streams for Deep Learning analytics within the system.

3.2 Proactive storage management with WDDA

WD Purple® Pro drives support Western Digital® Device Analytics™ (WDDA), which provides a wealth of storage device parametric operational and diagnostic data to the system; algorithms interpret the data and direct the system to alert system administrators of specific recommended actions to address potential issues. WDDA is intended to empower OEMs, system integrators, and IT professionals to better monitor and proactively manage supported storage devices to maintain optimal operation

3.3 OptiNAND™ Technology

The WD Purple® Pro 24 and 26TB¹ HDD with OptiNAND™ technology delivers massive capacity in an enterprise-class drive for smart video systems to enable data-driven outcomes.

3.4 Triple Stage Actuator (TSA) Technology

The actuator on an HDD controls the head and arm assembly. Better control of the head and arm results in more accurate positioning, enabling higher capacity and performance.

The Triple Stage Actuator (TSA) is the latest industry innovation which uses 3-pivot points to precisely control the position of the recording head. TSA pivots points consist of VCM control, suspension loadbeam and slider/gimbal.

When the drive is powered off, the actuator automatically moves the head to the actuator ramp outside of the disk where it parks.

3.5 Two-Dimensional Magnetic Recording (TDMR) Technology

New technology which places two read heads onto each arm, thus allowing data tracks to be squeezed closer together, enabling higher areal density required for a 26TB capacity at 11 disks.

3.6 Rotational Vibration Safeguard (RSV)

Maintains drive performance in high rotational vibration environments and multi-drive systems.

3.7 Premium Protection

Designed with tarnish-resistant components, this WD Purple® Pro drive offers premium protection in harsh environments where surveillance systems may be installed.

3.8 SATA 6 Gb/s

SATA 6 Gb/s is the next generation interface for SATA hard drives with the following features:

- **Native Command Queuing (NCQ)** — server feature for performance in random I/O transaction environments. It aggregates many small random data transfers and allows the disk to reorder the commands in a sequential order for faster access.
- **Improved Power Management**— provides improved power management features including Host Initiated SATA Power Management (HIPM) and Device Initiated SATA Power Management (DIPM).

¹ 1TB = 1 trillion bytes. Actual user capacity may be less depending on operating environment.

- **Staggered Spin-up** — allows the system to control whether the drive will spin up immediately or wait until the interface is fully ready before spinning up.
- **Asynchronous Signal Recovery (ASR)** — robustness feature that improves signal recovery.
- **Enclosure Services** — defines external enclosure management and support features.
- **Backplane Interconnect** — defines how to lay out signal line traces in a backplane.
- **Auto-activate DMA** — provides increased command efficiency through automated activation of the DMA controller.
- **Device Configuration Overlay (DCO)** — allows hiding of supported features via a SATA feature mask.

3.9 Dynamic Fly Height Control

This feature is designed to compensate for head/media separation changes due to temperature and altitude. It adds video quality margins across temperature and altitude changes.

3.10 Energy-assisted PMR (ePMR)

ePMR is the first implementation of EAMR new technology. It utilizes a bias current applied to the head to enhance writability.

This technology gives Western Digital HDDs areal density leadership while maintaining the reliability & performance needed for data center workloads.

3.11 NoTouch™ Ramp Load Technology

Parks the recording heads off the disk surface during spin up, spin down and when the drive is off. This ensures the recording head never touches the disk surface resulting in improved long term reliability due to less head wear, and improved non- operational shock tolerance.

3.12 Advanced Format (AF)

Technology adopted by WD and other drive manufacturers as one of multiple ways to continue growing hard drive capacities. AF is a more efficient media format that enables increased areal densities.

3.13 Native Command Queuing (NCQ)

These drives support Native Command Queuing. NCQ is a true Enterprise feature for environments such as database, Web servers, and e-mail servers.

Performance of a random I/O workload can be improved through intelligent re- ordering of the I/O requests so they read/write to and from the nearest available sectors and minimize the need for additional disk revolutions or head actuator movement. This improvement is achieved through Native Command Queuing (NCQ).

NCQ allows the drive to re-order read commands, thereby increasing random read IOPs. Additional NCQ features that can prove beneficial include a Write Cache disabled IOP increase and a queuing implementation built upon an existing, highly automated cache architecture. Queued reads in NCQ leverage the same re-ordering schemes used for write caching. The firmware design maintains the "order" of overlapping/colliding queued commands. NCQ is designed to excel in multi- threaded environments with high random I/O loads.

3.14 S.M.A.R.T. Command Transport (SCT)

The SCT Command Transport feature set provides a method for a host to send commands and data to a device and for a device to send data and status to a host using log pages. Standard ATA commands may be interspersed with SCT commands, but SCT commands cannot be nested. SCT commands that do not require a subsequent data transfer operation are not interspersed with any ATA commands or each other.

The SCT Command Transport feature set provides a method for a host to send commands and data to a device and for a device to send data and status to a host using log pages. This capability is used to pass commands through a driver interface or a bridge where new or unknown commands may be filtered and not passed to the drive. SCT is also used for issuing commands that require more than 8 parameter bytes. ACS provides detailed information on the usage and capabilities of SCT. The SCT feature set includes the following commands:

- Write Same
- Temperature Reporting

3.14.1 Write Same

The Write Same command allows the host to erase the media, or write a pattern repeatedly across the media, with a minimum of data transfer from the host. The host can clear the entire media to zeros or a specific pattern by sending this command with the pattern as a parameter—no data transfer is necessary. Write Same can write the entire media, or just a portion of the media. The host can monitor the progress of the Write Same by issuing SCT Status requests. This frees the host system to do other tasks while the media is being cleared.

3.14.2 Temperature Reporting

The SCT Temperature Reporting (SCT TR) feature allows a host system to access temperature information in the drive. The S.M.A.R.T. temperature value is reported within $\pm 3^{\circ}\text{C}$ of the base casting temperature. This information can be used to control fans or adjust the usage of various system components to keep the drive within its normal operating temperature. Applications include Enterprise, Laptop, Desktop and Consumer Electronics. SCT TR reports the maximum and minimum sustained operating limits, warning level limits, and drive damage limits. In addition to reporting the limits, SCT TR returns the current drive temperature (a temperature history which the host can use to predict heating or cooling trends) and the maximum temperature achieved during the lifetime of the drive as well as the highest temperature achieved since the power was applied to the drive. Detailed information on this capability can be found in ACS.

3.15 World Wide Name (WWN)

It has become a critical requirement that hard drives be uniquely identified by computer systems. This allows a drive to maintain its identity as it is transported from

system to system or placed on a network. IEEE has defined a format for serial numbers that is widely recognized in the computing industry by adding World Wide Name (WWN) to ATA/ATAPI-7 in 2002.

The World Wide Name (WWN) defined in ATA/ATAPI-7 is a modification of the IEEE Extended Unique Identifier 64 bit standard (EUI-64) and is comprised of three major components: naming authority, organizationally unique identifier (OUI) and serial number. WD's OUI is 0014EEH.

3.16 Reliability Features Set

3.16.1 Thermal Management

The drive is designed with Thermal Management features for high reliability.

- **State-of-the-art mechanical design**—Mechanical design is optimized to reduce the drive's temperature. State-of-the-art thermal dissipation and windage design is employed.
- **Closed loop servo management**—Thermal management monitors the drive temperature and can control servo operations to maintain a stable operating temperature under high temperature conditions. This is a closed loop servo and thermal control system.
- **S.M.A.R.T. HDA Temperature Attribute**—The S.M.A.R.T. HDA Temperature Attribute is supported. The S.M.A.R.T. temperature value is reported within $\pm 3^{\circ}\text{C}$ of the base casting temperature.
- **Ducted airflow**—Provides protection to the Read/Write element from heated air.

3.16.2 Internal Environmental Protection System

This dual filter system protects the inside environment of the drive from contamination. System features include:

- Dual Filtration System to ensure fast clean-up times
- Directed airflow to maximize mechanical cooling
- Increase casting surface area to maximize cooling
- Ducted air flow to protect Read Rite elements from heated air
- Enhanced heat dissipation

3.16.3 Unrecoverable Errors

If an unrecoverable error is found during the offline scan, the sector is marked. Future reads from this location will continue to perform full error recovery. However, the next write to this location will perform a sector test to be sure the media is not damaged, and the sector relocated if the sector test fails.

3.16.4 Self Test

Self Test is a quick way to determine the operation status of a drive. The following Self Tests are supported:

- **Quick Test:** Completes in less than two minutes.
- **Extended Test:** Tests all the critical subsystems of the drive.
- **Conveyance Test:** Quickly identifies issues caused by handling damage.
- **Selective Test:** Scans host-defined sections of the drive.

The test may be run to completion or be performed as a background task as the drive processes other commands from the host. The host may then poll the drive for runtime status and test results. Since the test is embedded in the drive's firmware, it is always available, requires no installation and can be faster and more effective than a software-based drive test.

3.16.5 ATA Error Logging

ATA Error Logging provides an industry standard means to record error events and supporting information that is then accessible by the host. The event record includes the exact command that caused the failure, the response of the drive, the time of the event and information about the four commands immediately prior to the errant command. Error Logging can reliably and quickly determine whether a system problem is the result of a hard drive failure or other component malfunction. Error Logging retains total error count for the life of the drive and complete records for the last five errors.

3.16.6 Defect Management

Every WD drive undergoes factory-level intelligent burn in, which thoroughly tests for and maps out defective sectors on the media before the drive leaves the manufacturing facility. Following the factory tests, a primary defect list is created. The list contains the cylinder, head, and sector numbers for all defects.

Defects managed at the factory are sector slipped. Grown defects that can occur in the field are mapped out by relocation to spare sectors on the inner cylinders of the drive.

3.17 Automatic Defect Retirement

The automatic defect retirement feature automatically maps out defective sectors while reading or writing. If a defective sector appears, the drive finds a spare sector.

The following item is specific to automatic defect retirement on writes (write auto-relocation):

- Data is always written to disk (using automatic defect retirement if required) and no error is reported.

The following item is specific to automatic defect retirement on reads (read auto-relocation):

- When host retries are enabled, the drive will internally flag any unrecoverable errors (DAMNF or ECC). This flagging allows subsequent write commands to this location to relocate the sector only if the sector test fails.

3.17.1 Error Recovery Process

The drive has five means of error recovery:

- ECC On-the-Fly
- Preamp Thermal Asperity (TA) Compensation
- Read/Write Retry Procedure
- Extended Read Retry Procedure

ECC On-the-Fly – If an ECC error occurs, the drive attempts to correct it on-the-fly without retries. Data can be corrected in this manner without performance penalty. The details of the correction algorithm appear in the next section.

Preamp Thermal Asperity Compensation – A Thermal Asperity (TA) is a baseline shift in the readback signal due to heating of the magnetoresistive stripe on the head as a result of physical contact with the disk or a particle. The preamp circuit has the ability to detect and compensate for thermal asperities. When an error cannot be corrected by ECC On-the-Fly, another retry is performed, where the preamp with its thermal asperity detection feature determines if the error is due to a thermal asperity. Once the preamp determines that the error is due to thermal asperity, preamp compensation is enabled. If preamp compensation alone is not enough to recover, then the channel performs a series of TA-specific recoveries.

Read/Write Retry Procedure – This retry procedure is used by all disk controller error types. If the procedure succeeds in reading or writing the sector being tried, then recovery is complete and the controller continues with the command. Each retry operation also checks for servo errors. The procedure ends when error recovery is achieved or when all possible retries have been attempted.

Extended Read Retry Procedure – This retry procedure tries combinations of positive/negative track offsets and data DAC manipulations to recover the data. This retry procedure applies only to read data recovery. The Read/Write Retry procedure performs the actual retry operation.

When an extended retry operation is successful, the controller continues with the command. The controller clears any changes in track offset or data DAC settings before the command continues.

3.18 Hot Plug Support

SATA supports hot plugging (also known as "hot swapping"), the ability to swap out a failed hard drive without having to power down the system or reboot. This capability contributes to both data availability and serviceability without any associated downtime, making it a critical feature for extending SATA into enterprise applications.

These WD hard drives support SATA hot plugging only in systems where a SATA hard drive storage backplane is used.

The Serial ATA specification requires staggered pins for both the hard drive and drive receptacles. Staggered pins mate the power signals in the appropriate sequences required for powering up the hot plugged device. These pins are also specified to handle in excess of the maximum allowed inrush current that occurs during drive insertion. SATA-compliant devices thus need no further modification to be hot pluggable and provide the necessary building blocks for a robust hot plug solution, which typically includes:

- Device detection even with power downed receptacles (typical of server applications).
- Pre-charging resistors to passively limit inrush current during drive insertion.
- Hot plug controllers to actively limit inrush current during drive insertion.

3.19 Active LED Status

The drive supports external LED requirements. It provides an activity LED output which is ON during command execution and OFF otherwise.

The drive strength of this open Drain Drive Active signal is that it can sink 12mA to 0.4V Max. It is 5V tolerant, meaning that the external LED may be driven from +5V or +3.3V so long as the Host system provides a series resistor to limit the LED current to the lower of 12mA or the rated operating current of the LED. As an example with +5V and a 2 volt forward drop across a 10mA LED, a 300 Ohm 5% 1/16W resistor would be suitable. In the case of a 3.3V supply for the same LED, the resistor would be 130 Ohm 5% 1/16W.

The pin corresponding to P11 shall be used for Active LED ((see [Section 2.4.4 Connectors and Cables](#) on page 13).

3.20 Fluid Dynamic Bearings (FDB)

Bearing design that incorporates a layer of high-viscosity lubricant instead of ball bearings in the hard drive spindle motor. As an alternative to conventional ball bearing technology, FDB designs provide increased non-operational shock resistance, speed control, and improved acoustics.

3.21 Staggered Spinup and Activity Indication (SATA Power Pin 11)

Note: This feature is available for specific OEM configurations.

SATA device power connector pin 11 (see [Section 2.4.4.2 Cabling Requirements for Serial ATA](#) on page 13) is defined as a means by the host to DISABLE staggered spinup and it may also be used by the device to provide the host with an activity indication. According to the SATA spec, "Staggered Spin-up Disable and Activity Signal shall not be enabled at the same time."

3.22 48-bit Logical Block Addressing (LBA)

The 48-bit Address feature set allows devices with capacities up to approximately 281 tera sectors or approximately 144 peta bytes. In addition, the number of sectors that may be transferred by a single command are increased by increasing the allowable sector count to 16-bits.

Table 14 48-bit Logical Block Addressing (LBA)

48-bit Address					
Bits (47:40)	Bits (39:32)	Bits (31:24)	Bits (23:16)	Bits (15:8)	Bits (7:0)
LBA High (exp)	LBA Mid (exp)	LBA Low (exp)	LBA High	LBA Mid	LBA Low

16-bit Sector Count	
Bits (15:8)	Bits (7:0)
Sector Count (exp)	Sector Count

3.23 Power Management

This drive supports the ATA power management commands that lower the average power consumption of the hard drives. For example, to take advantage of the lower power consumption modes of the drive, an energy efficient host system could implement a power management scheme that issues a Standby Immediate command when a host resident disk inactivity timer expires. The Standby Immediate command causes the drive to spin down and enter a low-power mode. Subsequent disk access commands would cause the drive to spin up and execute the new command. To avoid excessive wear on the drive due to the starting and stopping of the HDA, set the host's disk inactivity timer to no shorter than ten minutes.

The drive also supports the SATA power management feature that lowers the average power consumption of the SATA interface.

3.24 Self-Monitoring, Analysis, and Reporting Technology (S.M.A.R.T.)

S.M.A.R.T. helps you monitor a drive's internal status through diagnostic commands at the host level.

The drive monitors Read Error Rate, Start/Stop Count, Re-allocated Sector Count, Seek Error Rate, Power-on Hours Count, Spin-up Retry Count, Drive Calibration Retry Count, Drive Power Cycle Count, Offline Scan Uncorrectable Sector Count, Ultra ATA CRC Error Rate, Multi-zone Error Rate, Spin-up Time, Relocation Event Count, and Current Pending Sector Count. The hard drive updates and stores these attributes in the reserved area of the disk. The drive also stores a set of attribute thresholds that correspond to the calculated attribute values. Each attribute threshold indicates the point at which its corresponding attribute value achieves a negative reliability status.

3.25 Security Mode

The Security Mode feature set allows the user to create a device lock password that prevents unauthorized hard drive access even if the drive is removed from the computer. This feature varies by drive configuration and may not be available on all configurations.

3.25.1 Master and User Passwords

The manufacturer/dealer can set a master password using the Security Set Password command, without enabling the device lock function. The user password should be given or changed by a system user.

Master Password Identifier is supported and set to a default value of 00FE. If a Master Password is set via a Security Set Password Command, a valid Master Password Revision code value of 0001h – FFFEh must be used. A Master Password Identifier of 0000h is ignored.

When the master password is set, the drive does *not* enable the device lock function. When the user password is set, the drive enables the device lock function, and the drive is locked after the next power on reset or hard reset.

3.25.2 Security Levels

High - If High level security is set and the user password is forgotten, the master password can be used to unlock the drive and access the data.

Maximum - If Maximum level security is set and the user password is forgotten, data access is impossible. Only the master password with a Security Erase Unit command can unlock the drive when the device lock function is enabled and the user password has been forgotten. When the Security Erase Unit command is used to unlock the drive, all user data is erased.

4.0 ATA COMMAND SET

4.1 Host Interface Commands

4.1.1 ATA Commands

Table 15 lists the hexadecimal codes specific to each ACS command supported by these hard drives. Refer to the ACS specification for full details on each command.

Table 15 ACS Command Opcodes

COMMAND	HEX OPCODE
CHECK POWER MODE	E5
DEVICE CONFIGURATION OVERLAY	B1
DOWNLOAD MICROCODE	92
EXECUTE DEVICE DIAGNOSTIC	90
FLUSH CACHE	E7
FLUSH CACHE EXT	EA
IDENTIFY DEVICE	EC
IDLE	E3
IDLE IMMEDIATE	E1
NOP	00
READ BUFFER	E4
READ DMA	C8
READ DMA EXT	25
READ FPDMA QUEUED	60
READ LOG EXT	2F
READ LOG DMA EXT	47
READ MULTIPLE	C4
READ MULTIPLE EXT	29
READ NATIVE MAX ADDRESS	F8
READ NATIVE MAX ADDRESS EXT	27
READ SECTOR(S)	20
READ SECTORS(S) EXT	24
READ VERIFY SECTOR(S) EXT	42
READ VERIFY SECTORS(S)	40
S.M.A.R.T.	B0
SECURITY DISABLE PASSWORD	F6
SECURITY ERASE PREPARE	F3
SECURITY ERASE UNIT	F4
SECURITY FREEZE LOCK	F5
SECURITY SET PASSWORD	F1
SECURITY UNLOCK	F2
SET FEATURES	EF
SET MAX	F9
SET MAX ADDRESS EXT	37
SET MULTIPLE	C6
SLEEP	E6

Table 16 ACS Command Opcodes (Continued)

COMMAND	HEX OPCODE
STANDBY	E2
STANDBY IMMEDIATE	E0
WRITE BUFFER	E8
WRITE DMA	CA
WRITE DMA EXT	35
WRITE FPDMA QUEUED	61
WRITE LOG EXT	3F
WRITE LOG DMA EXT	57
WRITE MULTIPLE	C5
WRITE MULTIPLE EXT	39
WRITE SECTOR(S)	30
WRITE SECTOR(S) EXT	34
WRITE UNCORRECTABLE EXT	45

4.2 SCT Commands

SCT commands provide capabilities not covered in ATA/ATAPI-7 for commands that do not fit the ATA command delivery model. Some SCT commands report completion when the command begins execution. Execution progress for these commands may be checked by requesting SCT status. For instance, the host can track the progress of a Write Same command by issuing a status request once per minute. See ACS for a full description of SCT.

Table 17 SCT Action Codes

ACTION CODE	DESCRIPTION
0000h	RESERVED
0001h	Obsolete
0002h	Write Same
0003h	Error Recovery Control
0004h	Features Control
0005h	SCT Data Tables
0006h	Vendor specific
0007h	SCT BIST
C000h	FFFFh Vendor specific

4.3 S.M.A.R.T. (B0h)

The S.M.A.R.T. command provides access to attribute values, S.M.A.R.T. status, and other S.M.A.R.T. information. These commands can be used for logging and reporting purposes, and for accommodating special user needs.

Prior to writing the S.M.A.R.T. command to the Command Register, the host must write key values into the LBA Mid and LBA High Registers (4Fh, C2h) or the command will be aborted and an error will be reported.

The S.M.A.R.T. command has several sub-commands that are selectable via the Features Register when the host issues the S.M.A.R.T. command. To select a sub-command, the host must write the appropriate sub-command code to the Features Register before issuing the S.M.A.R.T. command. The sub-commands and their respective codes are listed below. For more detailed information on executing S.M.A.R.T. commands, see the ATA-7 specification.

4.3.1 Read Attribute Values Sub-Command

This command returns a sector of data with the drive's S.M.A.R.T. data structure.

Table 18 Definitions for the 512 Bytes

BYTE	VALUE	DESCRIPTION
0 - 1	0010h	S.M.A.R.T. Data Structure Revision
2 - 361	XX	S.M.A.R.T. Attribute Data
135 - 361	XX	S.M.A.R.T. Attribute Data
362	XX	Offline data collection status 0Xh OL disabled 8Xh OL enabled X0h scan not run X2h scan complete X4h scan suspended X5h scan aborted
363	XX	Self-Test execution status byte 00h The previous self-test routine completed without error or no self-test has ever been run 01h The self-test routine was aborted by the host 02h The self-test routine was interrupted by the host with a hard or soft reset 03h A fatal error or unknown test error occurred while the device was executing its self-test routine. The device was unable to complete the self-test routine. 04h The previous self-test completed having a test element that failed. The test element that failed is not known. 05h The previous self-test completed having a test element that failed. The electrical element of the test failed. 06h The previous self-test completed having a test element that failed. The servo (and/or seek) test element of the test failed. 07h The previous self-test completed having a test element that failed. The read element of the test failed. 08h The previous self-test completed having a test element that failed. The element damage is suspected to be caused by handling. 09-0Eh Reserved 0Fh Self-test routine in progress
364 - 365	XX	Total time in seconds to complete offline data collection activity
366	XX	Reserved
367	05Bh	Offline data collection capability. Bits are as follows: 0 1 = Offline Immediate Command supported 1 1 = Auto Offline enable\disable command supported 2 0 = Offline will suspend on and will resume after host command 3 1 = Offline read scan implemented 4 1 = DST Short and Extended tests supported 1 = DST Conveyance test supported 6-7 0 - Reserved
368 - 369	0003h	S.M.A.R.T. Capability. Bits are as follows: 0 1 = The device saves SMART data prior to going into a power saving mode 1 1 = Device complies with SMART data autosave after an event 2-15 Reserved
370	01h	Error logging capability. Bits are as follows: 0 1 = Error logging supported 0 Reserved
371	XX	Reserved

Table 19 Read Attribute Values Sub-Command (Continued)

BYTE	VALUE	DESCRIPTION
371	XX	Reserved
372	XX	Short self-test routine completion time in minutes
373	XX	Extended self-test routine completion time in minutes
374	XX	Conveyance self-test routine completion time in minutes
375 - 510	XX	Reserved
511	XX	Checksum

4.3.2 Supported Attributes

The drive supports the following attributes.

Table 20 Supported Attributes

Attribute	Attribute ID Number	Pre-Failure/Advisory Bit (Status Flags bit 0) ¹
Raw Read Error Rate	1	Pre-Failure
Throughput Performance	2	Advisory
Spin-up Time	3	Pre-Failure
Start/Stop Count	4	Advisory
Re-allocated Sector Count	5	Pre-Failure
Seek Error Rate	7	Advisory
Seek Time Performance	8	Advisory
Power-on Hours Count	9	Advisory
Spin Retry Count	10	Advisory
Drive Power Cycle Count	12	Advisory
Internal Environment Status (Helium Status)	22	Pre-Failure
Power Off Retract Count	192	Advisory
Load/Unload Cycles	193	Advisory
Temperature ²	194	Advisory
Relocation Event Count	196	Advisory
Current Pending Sector Count	197	Advisory
Off-Line Scan Uncorrectable Sector Count	198	Advisory
Ultra DMA CRC Error Count / Frame Error Count	199	Advisory

¹ Status bits are typical but may vary.

² See [Section 3.13.2 Temperature Reporting](#) on page 20 for a better mechanism.

Attributes that use the Pre-Failure/Advisory Bit Set can predict potential future degrading or faulty conditions. Attributes with the Failure/Advisory Bit Clear are used for informational purposes only, they do not indicate impending drive failure.

The S.M.A.R.T. data saving process is a background task. After a pre-determined idle period, the self-monitoring data is automatically saved to the disk.

4.3.3 Read Log Sector

There are several logs that can be read with the S.M.A.R.T. Read Log Sector sub-command. The LBA Low Register indicates the log sector to be returned.

Table 21 Log Address Definition

Log Address	Log Name	Feature Set	R/W	Access
00h	Log directory	ExtLog	RO	GPL, SL
01h	Summary Log	SMART	RO	SL
02h	Comprehensive SMART error log	SMART	RO	SL
03h	Extended Comprehensive SMART error log	ExtLog	RO	GPL
04h	Device Statistics	N/A	RO	GPL, SL
05h	Reserved	Reserved	Reserved	
06h	SMART self-test log	SMART	RO	SL
07h	Extended SMART self-test log	ExtLog	RO	GPL
08h	Reserved	Reserved	Reserved	
09H	Selective self-test log	SMART	R/W	SL
0Ah-0Fh	Reserved	N/A	Reserved	
10h	NCQ Command Error	NCQ	RO	GPL
11h	SATA PHY Counters	ExtLog	RO	GPL
12h-17h	Reserved for Serial ATA	N/A	Reserved	
18h-1Fh	Reserved	N/A	Reserved	
20h	Obsolete			
21h	Write Stream Error Log	Streaming	RO	GPL
22h	Read Stream Error Log	Streaming	RO	GPL
23h	Obsolete			
24h-7Fh	Reserved	N/A	Reserved	
80h-9Fh	Host vendor specific	SMART / ExtLog	R/W	GPL, SL
A0h-BFh	Device vendor specific	SMART / ExtLog	VS	GPL, SL
C0h-EFh	Reserved	Reserved	Reserved	
E0h	SCT Command/Status	N/A	R/W	GPL, SL
E1h	SCT Data Transfer			GPL, SL
E2h-FFh	Reserved	Reserved	Reserved	
00h	Log directory	ExtLog	RO	GPL, SL
01h	Summary Log	SMART	RO	SL

RO - Read Only

R/W - Read / Write

SMART - Supported by B0h command code.

ExtLog - Supported by 2Fh/3Fh command code.

VS - Vendor Specific

SCT - SMART Command Transport

4.4 Identify Device (ECh)

The Identify Device command transfers 512 bytes of data that specify the drive's parameters. The following Tables list the parameters read by the host

Table 22 Identify Device Command

WORD	FIELD DESCRIPTION	VALUE
0	General Configuration	045Ah
1	Obsolete	XXh
2	Specific Configuration	XXXX
3	Obsolete	XXh
4-5	Retired	XXh
6	Obsolete	XXh
7-8	Reserved for assignment by the CompactFlash™ Association	0
9	Retired	XXh
10-19	Serial Number (ATA String)	nnnnnnnnnn
20-21	Retired	XXh
22	Obsolete	XXh
23-26	Firmware Revision (ATA String)	nnnn
27-46	Model Numbers (ATA String)	"WDC WD2xxHKAI-nnnnnnn"
47	READ/WRITE MULTIPLE support Bit 15-8: 80h Bit 7-0: 00h: Reserved 01h-FFh = Maximum number of logical sectors that shall be transferred per DRQ data block on READ/WRITE MULTIPLE commands	8010h
48	Trusted Computing feature set options Bit 15: Shall be cleared to zero Bit 14: Shall be set to one Bit 13-1: Reserved for the Trusted Computing Group Bit 0: If set, Trusted Computing feature set is supported	04000h
49	Capabilities Bit 15-14: Reserved for the IDENTIFY PACKET DEVICE command. Bit 13: If set, Standby timer values as specified in this standard are supported. 0 = Standby timer values shall be managed by the device Bit 12: Reserved for the IDENTIFY PACKET DEVICE command Bit 11: If set, IORDY supported Bit 10: If set, IORDY may be disabled Bit 9: If set, LBA supported Bit 8: If set, DMA supported Bit 7-2: Reserved Bit 1: Current Long Physical Alignment Setting	2F00h
50	Capabilities Bit 15: Shall be cleared to zero. Bit 14: Shall be set to one. Bit 13-2: Reserved. Bit 1: Obsolete Bit 0: Shall be set to one to indicate a device specific Standby timer value minimum	4000h
51-52	Obsolete	XXh

ATA Command Set

Table 23 Identify Device Command (Continued)

WORD	FIELD DESCRIPTION	VALUE
53	Additional Words Valid Bit 8-15: Free-fall Control Sensitivity 00h = Vendor's recommended setting 01h-FFh = Sensitivity level. A larger number is a more sensitive setting. Bit 7-3: Reserved Bit 2: If set, the fields reported in word 88 are valid Bit 1: If set, the fields reported in words 70-64 are valid Bit 0: Obsolete	0007h
54-58	Obsolete	xxxxh
59	Current Blocking Factor Bit 15: 1=The BLOCK ERASE EXT command is supported Bit 14: 1= The OVERWRITE EXT command is supported Bit 13: 1=The CRYPTO Scramble EXT command is supported Bit 12: 1=The Sanitize feature set is supported Bit 9-11 Reserved Bit 8: 1=Multiple local sector setting is valid Bit 0-7: Current setting for number of logical sectors that shall be transferred per DRQ data block on READ/ WRITE Multiple commands	5900h
60-61	Total number of user addressable logical sectors for 28 bit commands (DWord)	OFFFFFFFFh
62	Obsolete	xxxxh
63	Multi-Word DMA Transfer Mode Supported Bit 15-11: Reserved Bit 10: If set, Multiword DMA mode 2 is selected Bit 9: If set, Multiword DMA mode 1 is selected Bit 8: If set, Multiword DMA mode 0 is selected Bit 7-3: Reserved Bit 2: If set, Multiword DMA mode 2 Bit 1: If set, Multiword DMA mode 1 Bit 0: If set, Multiword DMA mode 0	XX07h
64	Advanced PIO Modes Supported Bits 0-7: PIO Modes supported	0003h
65	Min. Multi-Word DMA Transfer Cycle Time (ns) Bit 15-0: Cycle time in nanoseconds	0078h
66	Manufacturer Recommended Multi-Word DMA Cycle Time Bit 15-0: Cycle time in nanoseconds	0078h
67	Min. PIO Transfer Cycle Time without flow control Bit 15-0: Cycle time in nanoseconds	0078h
68	Min. PIO Transfer Cycle Time with IORDY flow control Bit 15-0: Cycle time in nanoseconds	0078h
69	Additional Supported Bit 15: If set, CFAST Specification Support Bit 14: If set, Deterministic data in trimmed LBA range(s) is supported Bit 13: If set, Long Physical Sector Alignment Error Reporting Control is supported Bit 12: If set, DEVICE CONFIGURATION IDENTIFY DMA and DEVICE CONFIGURATION SET DMA are supported Bit 11: If set, READ BUFFER DMA is supported Bit 10: If set, WRITE BUFFER DMA is supported Bit 9: If set, SET MAX SET PASSWORD DMA and SET MAX UNLOCK DMA are supported Bit 8: If set, DOWNLOAD MICROCODE DMA is supported Bit 6: If set, Optional ATA device 28-bit commands supported ODE DMA is supported Bit 7: If set, Reserved for IEEE 1667 Bit 5: If set, Trimmed LBA range(s) returning zeroed data is supported Bit 4: If set, Device Encrypts All User Data Bit 3: If set, Extended Number of User Addressable Sectors is supported Bit 2-0: Reserved	0D08h

ATA Command Set

Table 24 Identify Device Command (Continued)

WORD	FIELD DESCRIPTION	VALUE
69	<p>Additional Supported</p> <ul style="list-style-type: none"> Bit 15: If set, CFAST Specification Support Bit 14: If set, Deterministic data in trimmed LBA range(s) is supported Bit 13: If set, Long Physical Sector Alignment Error Reporting Control is supported Bit 12: If set, DEVICE CONFIGURATION IDENTIFY DMA and DEVICE CONFIGURATION SET DMA are supported Bit 11: If set, READ BUFFER DMA is supported Bit 10: If set, WRITE BUFFER DMA is supported Bit 9: If set, SET MAX SET PASSWORD DMA and SET MAX UNLOCK DMA are supported Bit 8: If set, DOWNLOAD MICROCODE DMA is supported Bit 7: If set, Reserved for IEEE 1667 Bit 6: If set, Optional ATA device 28-bit commands supported ODE DMA is supported Bit 5: If set, Trimmed LBA range(s) returning zeroed data is supported Bit 4: If set, Device Encrypts All User Data Bit 3: If set, Extended Number of User Addressable Sectors is supported Bit 2-0: Reserved 	0D08h
70	Reserved	0
71-74	Reserved for the Identify Packet Device command	0
75	<p>Queue Depth</p> <ul style="list-style-type: none"> Bit 15-5: Reserved Bit 4-0: Maximum queue depth - 1 	001Fh
76	<p>Serial ATA Capabilities</p> <ul style="list-style-type: none"> Bit 15-13: Reserved Bit 12: Supports Native Command Queuing priority information Bit 11: Supports Unload while NCQ commands outstanding Bit 10: Supports Phy event counters Bit 9: Supports receipt of host-initiated interface power management requests Bit 8: Supports Native Command Queuing (NCQ) Bit 7-4: Reserved for future Serial ATA signaling speed grades Bit 3: 1= Supports Serial ATA Gen3 signaling speed (6 Gb/s) Bit 2: 1= Supports Serial ATA Gen2 signaling speed (3 Gb/s) Bit 1: 1= Supports Serial ATA Gen1 signaling speed (1.5 Gb/s) Bit 0: Shall be cleared to zero 	970Eh
77	Reserved for Serial ATA	0176h
78	<p>Serial ATA Features Supported</p> <ul style="list-style-type: none"> Bit 7-15: Reserved for Serial ATA Bit 6: If set, device supports software settings preservation Bit 5: Reserved for Serial ATA Bit 4: If set, device supports in-order data delivery Bit 3: If set, device supports initiating power management Bit 2: If set, device supports DMA Setup Auto-activation Bit 1: If set, device supports non-zero buffer offsets Bit 0: Cleared to zero 	1CDEh
79	<p>Serial ATA Features Enabled</p> <ul style="list-style-type: none"> Bits 7-15: Reserved for Serial ATA Bit 6: If set, software settings preservation enabled Bit 5: Reserved for Serial ATA Bit 4: If set, In-order data delivery enabled Bit 3: If set, device initiated power management enabled Bit 2: If set, DMA Setup Auto-activation enabled Bit 1: If set, non-zero buffer offsets enabled Bit 0: Cleared to zero 	0040h

ATA Command Set

Table 25 Identify Device Command (Continued)

WORD	FIELD DESCRIPTION	VALUE
80	Major Version Number Bit 15-10: Reserved Bit 9: if set, supports ACS-2 Bit 8: if set, supports ACS Bit 7: if set, supports ATA Bit 6: if set, supports ATA/ATAPI-6 Bit 5: if set, supports ATA/ATAPI-5 Bit 4 -1: Obsolete Bit 0: Reserved	1FFCh
81	Minor Version Number	0000h
82	Command and feature sets supported Bit 14: If set, NOP command supported Bit 13: If set, Read buffer command supported Bit 12: If set, Write buffer command supported Bit 11: Obsolete Bit 10: If set, Host Protected Area Feature Set supported Bit 9: If set, Device Reset command supported Bit 8: If set, Service interrupt supported Bit 7: If set, Release interrupt supported Bit 6: If set, look-ahead supported Bit 5: If set, Write Cache supported Bit 4: Cleared to 0 to indicate that the PACKET feature set is not supported. Bit 3: If set, mandatory Power Management Feature Set supported Bit 2: Obsolete Bit 1: If set, Security Feature Set supported Bit 0: If set, SMART Feature Set supported	746Bh
83	Command Set Supported Bit 15: Shall be cleared to 0 Bit 14: Shall be set to 1 Bit 13: If set, Flush Cache EXT command supported Bit 12: If set, mandatory Flush Cache command supported Bit 11: If set, DCO feature set supported Bit 10: If set, 48-bit Address Feature Set supported Bit 9: Not supported Bit 8: If set, Set Max Security Extension supported Bit 7: Reserved Bit 6: If set, Set Features subcommand required to spin-up after power-up Bit 5: If set, Power-Up In Standby feature set supported Bit 4: Obsolete Bit 3: If set, Advanced Power Management feature set supported Bit 2: If set, CFA feature set supported Bit 1: If set, Read/Write DMA Queued supported Bit 0: If set, Download Microcode command supported	7D69h
84	Command and feature sets supported Bit 15: Shall be cleared to zero Bit 14: Shall be set to one Bit 13: If set, Idle Immediate with Unload Feature supported Bit 12: Reserved Bit 11: Reserved Bit 9-10: Obsolete Bit 8: If set, 64-bit World wide name supported Bit 7: If set, Write DMA Queued FUA EXT command supported Bit 6: If set, Write DMA FUA EXT and Write Multiple FUA EXT commands supported Bit 5: If set, General Purpose Logging feature set supported Bit 4: If set, Streaming Feature Set supported Bit 3: Obsolete Bit 2: If set, Media serial number supported Bit 1: If set, SMART Self-Test supported Bit 0: If set, SMART Error Logging supported	4773h

ATA Command Set

Table 26 Identify Device Command (Continued)

WORD	FIELD DESCRIPTION	VALUE
85	Command and feature sets supported or enabled Bit 15: Obsolete Bit 14: If set, NOP command supported Bit 13: If set, Read Buffer command supported Bit 12: If set, Write Buffer command supported Bit 11: Obsolete Bit 10: If set, Host Protected Area has been established Bit 9: If set, DEVICE RESET command supported Bit 8: If set, SERVICE interrupt enabled Bit 7: If set, Release Interrupt enabled Bit 6: If set, Read look-ahead enabled Bit 5: If set, Volatile Write cache enabled Bit 4: Cleared to 0 to indicate that the PACKET feature set is not supported Bit 3: Set to 1 to indicate that the Mandatory Power Management feature set is supported Bit 2: Obsolete Bit 1: If set, Security Feature Set enabled Bit 0: If set, SMART Feature Set enabled	7469h
86	Commands and feature sets supported or enabled Bit 15: If set, Words 119-120 are valid Bit 14: Reserved Bit 13: If set, Flush Cache EXT command supported Bit 12: If set, Flush Cache command supported Bit 11: If set, Device Configuration Overlay supported Bit 10: If set, 48-bit Address Feature Set supported Bit 9: Not supported Bit 8: If set, Set Max Security Extension enabled by Set Max Set Password Bit 7: Reserved Bit 6: If set, Set Features subcommand required to spin-up after power-up Bit 5: If set, Power-Up In Standby feature set enabled Bit 4: Obsolete Bit 3: If set, Advanced Power Management feature set enabled Bit 2: If set, CFA Feature Set enabled Bit 1: If set, Read/Write DMA Queued command supported Bit 0: If set, Download Microcode command supported	BC69h
87	Commands and feature sets supported or enabled Bit 15: Shall be cleared to zero Bit 14: Shall be set to 1 Bit 13: If set, Idle Immediate with Unload Feature supported Bit 12: Reserved Bit 11: Reserved Bit 9-10: Obsolete Bit 8: If set, 64-bit World wide name supported Bit 7: If set, Write DMA Queued FUA EXT command supported Bit 6: If set, Write DMA FUA EXT and Write Multiple FUA EXT commands supported Bit 5: If set, General Purpose Logging Feature Set supported Bit 4: Obsolete Bit 3: If set, Media Card Pass Through Command feature set supported Bit 2: If set, Media serial number is valid Bit 1: If set, SMART Self-Test supported Bit 0: If set, SMART Error Logging supported	4773h

ATA Command Set

Table 27 Identify Device Command (Continued)

WORD	FIELD DESCRIPTION	VALUE
88	Ultra DMA modes Bit 15: Reserved Bit 14: If set, Ultra DMA Mode 6 is selected Bit 13: If set, Ultra DMA Mode 5 is selected Bit 12: If set, Ultra DMA Mode 4 is selected Bit 11: If set, Ultra DMA Mode 3 is selected Bit 10: If set, Ultra DMA Mode 2 is selected Bit 9: If set, Ultra DMA Mode 1 is selected Bit 8: If set, Ultra DMA Mode 0 is selected Bit 7: Reserved Bit 6: Ultra DMA mode 6 supported Bit 5: Ultra DMA mode 5 supported Bit 4: Ultra DMA mode 4 supported Bit 3: Ultra DMA mode 3 supported Bit 2: Ultra DMA mode 2 supported Bit 1: Ultra DMA mode 1 supported Bit 0: Ultra DMA mode 0 supported	107Fh
89	Bit 15-8: Reserved Bit 7-0: Time required for Normal Erase mode SECURITY ERASE UNIT command	8433h
90	Bit 15-8: Reserved Bit 7-0: Time required for Normal Erase mode SECURITY ERASE UNIT command	xxxxh
91	Current APM level value	XXXXh
92	Master Password Identifier	XXXXh
93	Hardware reset result	XXh
94	Obsolete	0
95	Stream Minimum Request Size	8
96	Stream Transfer Time - DMA	00CAh
97	Stream Access Latency -DMA and PIO	00F9h
98-99	Stream Performance Granularity (Dword)	2710h
100-103	Total number of User Addressable Logical Sectors (QWord)	WD260HKAI (50,782,535,680) WD241HKAI (46,875,541,504)
104	Streaming Transfer Time - PIO	00CAh
105	Maximum number of 512 byte blocks per Data Set Management command	0
106	Physical sector size / logical sector size Bit 15 Shall be cleared to zero Bit 14 Shall be set to one Bit 13 if set, Device has multiple logical sectors per physical sector. Bit 12 if set, Device Logical Sector longer than 256 Words Bits 11-4 Reserved Bits 3-0 2X logical sectors per physical sector	6003h
107	Inter-seek delay for ISO 7779 standard acoustic testing	5A87h
108-111	World Wide Name	XXXXXXXXXXXXXXXXXX
112-115	Reserved	0
116	Reserved for TLC	0
117-118	Logical Sector size (DWord)	0

ATA Command Set

Table 28 Identify Device Command (Continued)

WORD	FIELD DESCRIPTION	VALUE
119	Commands and feature sets supported (Continued from words 82-84) Bit 15: Cleared to zero Bit 14: Shall be set to one Bit 13-8: Reserved Bit 7: If set, Extended Power Conditions feature set supported Bit 6: If set, Sense Data Reporting supported Bit 5: If set, Free-fall Control feature set is supported Bit 4: If set, DOWNLOAD MICROCODE with offsets is supported Bit 3: If set, READ and WRITE DMA EXT GPL optional commands are supported Bit 2: If set, WRITE UNCORRECTABLE EXT is supported Bit 1: If set, Write-Read-Verify feature set is supported Bit 0: Reserved for DDT	405Ch
120	Commands and feature sets supported (Continued from words 85-87) Bit 15: Cleared to zero Bit 14: Shall be set to one Bit 13-8: Reserved Bit 7: If set, Extended Power Conditions feature set supported Bit 6: If set, Sense Data Reporting supported Bit 5: If set, Free-fall Control feature set is supported Bit 4: If set, DOWNLOAD MICROCODE with offsets is supported Bit 3: If set, READ and WRITE DMA EXT GPL optional commands are supported Bit 2: If set, WRITE UNCORRECTABLE EXT is supported Bit 1: If set, Write-Read-Verify feature set is supported Bit 0: Reserved for DDT	401Ch
121-126	Reserved	0
127	Obsolete	0
128	Security Status Bit 15-9: Reserved Bit 8: Security level (0 = High, 1 = Maximum) Bit 7-6: Reserved Bit 5: If set, Enhanced Security Erase supported Bit 4: If set, Security count expired Bit 3: If set, Security Frozen Bit 2: If set, Security Locked Bit 1: If set, Security enabled Bit 0: If set, Security supported	0009h
129-159	Vendor Specific	0
160	CFA power mode Bit 15: Word 160 supported Bit 14: Reserved Bit 13: CFA power mode Bit 12: CFA power mode 1 disable	0
161-167	Reserved for the CompactFlash™ Association	0
168	Device Nominal Form Factor Bit 15-4: Reserved Bit 3-0: Device Nominal Form Factor	0002h
169	Data Set Management Command Bit 15-1: Reserved Bit 0: if set, the Trim bit in the Data Set Management command supported	0
170-173	Additional Product Identifier	0
174-175	Reserved	0
176-205	Current Media Serial number	0

ATA Command Set

Table 29 Identify Device Command (Continued)

WORD	FIELD DESCRIPTION	VALUE
206	SCT Command Transport Bit 15-12: Vendor Specific Bit 11-6: Reserved Bit 5: If set, SCT Data tables command supported Bit 4: If set, SCT Features Control command supported Bit 3: If set, SCT Error Recovery Control command supported Bit 2: If set, SCT Write Same command supported Bit 1: If set, Obsolete Bit 0: If set, SCT Command Transport supported	003Dh
207-208	Reserved	0
209	Alignment of logical blocks within a physical block Bit 15: Shall be cleared to zero Bit 14: Shall be set to one Bits 13-0: Logical sector offset within the first physical sector where the first logical sector is placed.	4000h
210-211	Write-Read-Verify Sector Count Mode 3	0
212-213	Write-Read-Verify Sector Count Mode 2	0
214	NV Cache Capabilities Bit 15-12: NV Cache feature set version Bit 11-8: NV Cache Power Mode feature set version Bit 7-5: Reserved Bit 4: If set, NV Cache feature set enable Bit 3-2: Reserved Bit 1: If set, NV Cache Power Mode feature set enable Bit 0: if set, NV Cache Power Mode feature set supported	0
215-216	NV Cache Size in Logical Blocks	0
217	Nominal media rotation rate	1C20h
218	Reserved	0
219	NV Cache Options Bit 15-8: Reserved Bit 7-0: Device Estimate Time to spin up in seconds	0
220	Bit 15-8: Reserved Bit 7-0: Write-Read-Verify feature set current mode	0
221	Reserved	0
222	Transport major version number 0000h or FFFFh=device does not report version Bit 12-15: Transport Type (0h=Parallel 1h=Serial 2h-Fh=Reserved) Bit 6-11: Reserved (Parallel, Serial) Bit 5: Reserved SATA Rev. 3.0 Bit 4: Reserved SATA Rev. 2.6 Bit 3: Reserved SATA Rev. 2.5 Bit 2: Reserved SATA II: Extensions Bit 1: ATA SATA 1.0a Bit 0: ATA8-APT ATA8-AST	17FFh
223	Transport minor version number	0000h
224-229	Reserved	0
230-233	Extended Number of User Addressable Sectors (Qword)	xxh
234	Minimum number of 512-byte data blocks per DOWNLOAD MICROCODE command for mode 03h	0008h
235	Maximum number of 512-byte data blocks per DOWNLOAD MICROCODE command for mode 03h	0000h
236-254	Reserved	0
255	Integrity Word Bit 15-8: Checksum Bit 7-0: Signature	XXA5h

4.5 Set Features (EFh)

The Set Features command enables or disables the features listed in Table 32.

Table 30 Set Features (EFh)

Function	Features Register	Sector Count Register
Enable read look-ahead ¹	AAh	Don't care
Disable read look-ahead ¹	55h	Don't care
Enable write cache ¹	02h	Don't care
Disable write cache ¹	82h	Don't care
Set Transfer Mode	03h	Don't care
Enable use of Serial ATA Feature	10h	02h-DMA Setup FIS Auto-Activate optimization 06h-Software Settings Preservation
Disable use of Serial ATA Feature	90h	02h-DMA Setup FIS Auto-Activate optimization 06h-Software Settings Preservation

¹Changes are only valid while power remains applied to the drive. After power is cycled, the drive reverts to the default settings.

5.0 INSTALLATION AND SETUP PROCEDURES

Hard drives are precision instruments that must be handled with care to prevent damage. It is important to understand that drives are typically damaged because of Electrostatic Discharge (ESD), rough handling, or shock and vibration. Refer to the *WD Hard Drive Handling* for details on drive handling.

Refer to <http://www.westerndigital.com/support> for detailed instructions on all phases of repackaging the drive.

IMPORTANT: If your system does not support hot plugging (see [Section 3.18 Hot Plug Support](#) on page 24), it must be turned off and unplugged before installing your hard drive.

5.1 Unpacking

5.1.1 Handling Precautions

WD products are designed to withstand normal handling during unpacking and installation. Take care to avoid excessive mechanical shock or electrostatic discharge (ESD), which can permanently damage the hard drive and void the warranty. Hard drives are typically damaged because of ESD, rough handling, or shock and vibration.

To avoid ESD problems, wear a properly grounded wrist strap when handling the hard drive. Articles of clothing generate static electricity. Do not allow clothing to come in direct contact with the hard drive or circuit board components.

When the WD drive is not in its shipping container or installed in its proper host enclosure, it must remain in the antistatic bag. To prevent damage, do not unpack your WD drive until you are ready to install it.

5.1.2 Inspection of Shipping Container

Carefully examine the container for obvious shipping damage, such as: holes, signs of crushing, or stains. Notify the carrier and your WD representative if you observe any shipment damage. Always move the shipping container in the upright position indicated by the arrows on the container.

5.1.3 Removal From Shipping Container

Remove the WD drive from the shipping container only for inspection or installation. Carefully open the box. When removing the WD drive from the box, follow these precautions:

- Grasp the drive by the sides only; avoid touching the circuit board components.
- Gently place the drive on its antistatic bag on a clean, level, grounded work area.
- Do not stack drives or stand the WD drive on its edge.

CAUTION: When removing the drive from the shipping container, be careful not to drop it. Dropping the drive can severely damage the head disk assembly or printed circuit board.

5.1.4 Removal From Static Shielding Bag

Before removing the drive from its static shielding bag:

- Make sure that your work station is properly grounded.
- Wear a properly grounded wrist strap with good skin contact.
- Avoid contact with any component on the printed circuit board.

After attaching your wrist strap, gently remove the drive from the static shielding bag.

- Handle the drive by the sides only; avoid touching the printed circuit board.
- Handle the drive with the printed circuit board facing downward during installation.
- Do not open the drive's sealed compartment or remove the seals or any labels from the drive; this will void the warranty.

5.1.5 Moving Precautions

If you need to move your computer, turn off the power to automatically unload the heads. This helps protect the media and the heads from accidental damage due to vibration, moving, or shipping.

5.2 Hard Drive Installation

If your system does not support hot plugging (see [Section 3.18 Hot Plug Support on page 24](#)), it must be turned off and unplugged before installing your hard drive. This avoids the possibility of reversing the polarity of the power connections and eliminating current surges that can damage either the drive or computer.

5.3 Mounting

5.3.1 Drive Mounting

Use either the four bottom screws or at least four of the side mounting screws to rigidly support the drive and prevent vibration. Some adapter frames may not have the mechanical design structure capable of mounting the drive to meet the specified shock and vibration requirements.

The hard drive itself does not provide electrical isolation between mounting locations and drive ground connection. If electrical isolation is required, the system designer or integrator would be responsible for providing a solution.

5.3. Mounting Restrictions

If your system does not support hot plugging (see [Section 3.18 Hot Plug Support on page 24](#)), it must be turned off and unplugged before installing your hard drive.

5.3.3 Orientation

You can mount the hard drive in the X, Y, or Z axis, depending upon the physical design of your system. For best results, mount the drive with all four screws grounded to the chassis. If all four screws are not used, see [Section 5.3.5 Grounding on page 43](#).

5.3.4 Screw Size Limitations

The hard drive should be mounted to the chassis using four 6-32 screws. Recommended screw torque is 5 in-lb. Maximum screw torque is 10 in-lb.

CAUTION: Screws that are too long can damage the hard drive. Hard drive screw penetration can differ between products depending upon hard drive design. WD's minimum design criteria is to always meet the SFF 8301 industry standard specification. The industry standard as defined in the SFF 8301 specifies a maximum of 3 mm screw penetration, and for a minimum of 2.4 mm of thread engagement from both the screw and the hard drive.

See Figure 1 for allowable fastener penetration for this product family.

5.3.5 Grounding

The PCBA and HDA grounds are always connected together in the drive and cannot be disconnected. The drive mounting screws, unless intentionally isolated, will provide additional ground connections between the HDA and the system chassis. If the drive isn't grounded via mounting screws as described under *Section 5.2 Mounting on page 45*, there may be increased electrical emissions (EMI).

5.4 Serial ATA Latching Connector

This hard drive also allows Serial ATA latching cable connections. The latching connector provides a secure connection between the drive and the cable connector via a locking latch mechanism. The new latching connector design has two channels, one above the power connection and one above the data connection. Latch alignment with these channels forms an interlock when the latching cable is inserted into the drive. This latching feature makes the SATA connector more robust against breakage from downward force and ensures a click-lock connection which is verifiable even in noisy environments.

6.0 MAINTENANCE

The hard drive requires no preventative maintenance and contains no user-serviceable parts. The service and repair of drives can only be performed at a WD Service Center. Please contact your WD representative for warranty information and service/return procedures.

Observe the following precautions to prolong the life of the drive:

- Do not attempt to open the sealed compartment of the drive as this will void the warranty.
- Do not lift a drive by the printed circuit board.
- Avoid static discharge when handling a drive.
- Avoid harsh shocks or vibrations.
- Do not touch the components on the printed circuit board.
- Observe the environmental limits specified for this product.
- If it becomes necessary to move your computer system, turn off the power to automatically unload the heads. This helps protect the media and the heads from accidental damage due to vibration while moving or shipping.
- To protect your data, back it up regularly. WD assumes no responsibility for loss of data. For information about back-up and restore procedures, consult your operating system manual. There are also a number of utility programs available that you can use to back up your data.

7.0 TECHNICAL SUPPORT

NORTH AMERICA

US/Canada (Pacific Time - PT) **+1.800.ASK.4WDC (800.275.4932)**

Monday - Friday 8:00 am – 7:00 pm

Saturday - Sunday 8:00 am – 5:00 pm

EUROPE

Central European Time (CET) **(00)800.27549338 (toll-free where available) or +31.880062100**

Monday - Friday 9:00 am - 7:00 pm

7.1 WD Online Services

WD provides a wide variety of technical support services on our website at:
<http://www.westerndigital.com/support>.

8.0 THIRD-PARTY NOTICES

This product may include or use the following open source software subject to the following open source licenses. If required by the applicable open source license, Western Digital may provide the open source code to you on request either electronically or on a physical storage medium for a charge covering the cost of performing such distribution, which may include the cost of media, shipping, and handling.

Each third-party component that may be included is listed below, followed by its associated license text.

8.1 bzip2

<https://sourceware.org/bzip2/>

This program, "bzip2", the associated library "libbzip2", and all documentation, are copyright (C) 1996-2019 Julian R Seward. All rights reserved.

Redistribution and use in source and binary forms, with or without modification, are permitted provided that the following conditions are met:

1. Redistributions of source code must retain the above copyright notice, this list of conditions and the following disclaimer.
2. The origin of this software must not be misrepresented; you must not claim that you wrote the original software. If you use this software in a product, an acknowledgment in the product documentation would be appreciated but is not required.
3. Altered source versions must be plainly marked as such, and must not be misrepresented as being the original software.
4. The name of the author may not be used to endorse or promote products derived from this software without specific prior written permission.

THIS SOFTWARE IS PROVIDED BY THE AUTHOR "AS IS" AND ANY EXPRESS OR IMPLIED WARRANTIES, INCLUDING, BUT NOT LIMITED TO, THE IMPLIED WARRANTIES OF MERCHANTABILITY AND FITNESS FOR A PARTICULAR PURPOSE ARE DISCLAIMED. IN NO EVENT SHALL THE AUTHOR BE LIABLE FOR ANY DIRECT, INDIRECT, INCIDENTAL, SPECIAL, EXEMPLARY, OR CONSEQUENTIAL DAMAGES (INCLUDING, BUT NOT LIMITED TO, PROCUREMENT OF SUBSTITUTE GOODS OR SERVICES; LOSS OF USE, DATA, OR PROFITS; OR BUSINESS INTERRUPTION) HOWEVER CAUSED AND ON ANY THEORY OF LIABILITY, WHETHER IN CONTRACT, STRICT LIABILITY, OR TORT (INCLUDING NEGLIGENCE OR OTHERWISE) ARISING IN ANY WAY OUT OF THE USE OF THIS SOFTWARE, EVEN IF ADVISED OF THE POSSIBILITY OF SUCH DAMAGE.

Julian Seward, jseward@bzip.org

bzip2/libbzip2 version 1.0.8. (2019)

8.2 PCRE

<https://www.pcre.org/>

PCRE LICENCE

PCRE is a library of functions to support regular expressions whose syntax and semantics are as close as possible to those of the Perl 5 language.

Release 5 of PCRE is distributed under the terms of the "BSD" license, as specified below. The documentation for PCRE, supplied in the "doc" directory, is distributed under the same terms as the software itself.

Written by: Philip Hazel <Philip.Hazel@gmail.com>

University of Cambridge Computing Service, Cambridge, England. Phone: +44 1223 334714.

Copyright (c) 1997-2015 University of Cambridge All rights reserved.

Redistribution and use in source and binary forms, with or without modification, are permitted provided that the following conditions are met:

- Redistributions of source code must retain the above copyright notice, this list of conditions and the following disclaimer.
- Redistributions in binary form must reproduce the above copyright notice, this list of conditions and the following disclaimer in the documentation and/or other materials provided with the distribution.
- Neither the name of the University of Cambridge nor the names of its contributors may be used to endorse or promote products derived from this software without specific prior written permission.

THIS SOFTWARE IS PROVIDED BY THE COPYRIGHT HOLDERS AND CONTRIBUTORS "AS IS" AND ANY EXPRESS OR IMPLIED WARRANTIES, INCLUDING, BUT NOT LIMITED TO, THE IMPLIED WARRANTIES OF MERCHANTABILITY AND FITNESS FOR A PARTICULAR PURPOSE ARE DISCLAIMED. IN NO EVENT SHALL THE COPYRIGHT OWNER OR CONTRIBUTORS BE LIABLE FOR ANY DIRECT, INDIRECT, INCIDENTAL, SPECIAL, EXEMPLARY, OR CONSEQUENTIAL DAMAGES (INCLUDING, BUT NOT LIMITED TO, PROCUREMENT OF SUBSTITUTE GOODS OR SERVICES; LOSS OF USE, DATA, OR PROFITS; OR BUSINESS INTERRUPTION) HOWEVER CAUSED AND ON ANY THEORY OF LIABILITY, WHETHER IN CONTRACT, STRICT LIABILITY, OR TORT (INCLUDING NEGLIGENCE OR OTHERWISE) ARISING IN ANY WAY OUT OF THE USE OF THIS SOFTWARE, EVEN IF ADVISED OF THE POSSIBILITY OF SUCH DAMAGE.

9.0 GLOSSARY

Active LED Status — The WD drive supports external LED requirements. It provides an activity LED output which is ON during command execution and OFF otherwise.

Annualized Failure Rate (AFR) — A method of measuring failure rates or trends for a group of units at a site. The rates are based on the monthly total number of returned field failure units divided by the total cumulative installed base and multiplied by 12 (to annualize the failure rate).

Advanced Format (AF) — Technology adopted by WD and other drive manufacturers as one of multiple ways to continue growing hard drive capacities. AF is a more efficient media format that enables increased areal densities.

AllFrame™ Technology — All WD Purple® drives are equipped with Western Digital's exclusive AllFrame technology, which improves ATA streaming to help reduce frame loss, improve overall video playback, and increase the number of hard drive bays supported within a NVR. Help make your surveillance solution future-ready knowing that WD Purple drives are ready for ultra high definition cameras. WD Purple capacities up to 8TB feature AllFrame 4K technology enabling high quality recording for up to 64 cameras. WD Purple® Pro 4TB to 26TB¹ capacities feature AllFrame AI technology that enables not only recording up to 64 cameras, but also an additional 32 channels for Deep Learning analytics within the system.

Automatic Defect Retirement — If defective sectors are found during a read or write, they are automatically mapped out and relocated.

Block — A group of bytes handled, stored, and accessed as a logical data unit, such as an individual file record.

Buffer — A temporary data storage area that compensates for a difference in data transfer rates and/or data processing rates between sender and receiver.

Data Lifeguard™ — Representing WD's ongoing commitment to data protection, Data Lifeguard data protection utilities include thermal management, an environmental protection system, and embedded error detection and repair features that automatically detect, isolate, and repair problem areas that may develop over the extended use of the hard drive.

Data Transfer Rate — The rate that digital data is transferred from one point to another, expressed in bits per second or bytes per second.

Defect Management — A general methodology of eliminating data errors on a recording surface by mapping out known bad areas of the media.

Dual Stage Actuator Technology — A head positioning system with dual-stage actuators that improves positioning accuracy over the data track(s). The primary stage provides course displacement; the secondary stage uses piezoelectric motion to fine tune the head positioning to a higher degree of precision.

Dynamic Fly Height Control — This feature is designed to compensate for head/media separation changes due to temperature and altitude. It adds video quality margins across temperature and altitude changes.

Error Correction Code (ECC) — A mathematical algorithm that can detect and correct errors in a data field by adding check bits to the original data.

F.I.T. (Functional Integrity Testing) — A suite of tests WD performs on all its drive products to ensure compatibility with different hosts, operating systems, application programs, and peripherals. This testing must be performed before the product can be released to manufacturing.

Fluid Dynamic Bearings (FDB) — Bearing design that incorporates a layer of high-viscosity lubricant instead of ball bearings in the hard drive spindle motor. FDB designs provide increased non-operational shock resistance, speed control, and improved acoustics.

¹ 1TB = 1 trillion bytes. Actual user capacity may be less depending on operating environment.

Formatted Capacity — The actual capacity available to store data in a mass storage device. The formatted capacity is the gross capacity minus the capacity taken up by the overhead data required for formatting the media.

Hot Plugging — The ability to swap out a failed hard drive without having to power down the system or reboot.

Latency — The period of time that the read/write heads wait for the disk to rotate the data to an accessible position. For a disk rotating at 10,000 RPM, the average latency is 3 milliseconds.

Logical Block Address — An alternative addressing methodology of identifying a given location on a SATA drive that permits disk sizes greater than 528 MB.

Native Command Queuing (NCQ) — NCQ allows the drive to re-order read commands, thereby increasing random read IOPs. NCQ is a true Enterprise feature for environments such as database, Web servers, and e-mail servers.

NoTouch™ Ramp Load Technology — The recording head never touches the disk media ensuring significantly less wear to the recording head and media as well as better drive protection in transit.

OptiNAND™ — The WD Purple™ Pro 24 and 26TB¹ HDD with OptiNAND™ technology delivers massive capacity in an enterprise-class drive for smart video systems to enable data-driven outcomes.

Preemptive Wear Leveling (PWL) — WD feature that provides a solution for protecting the recording media against mechanical wear.

PRML (Partial Response Maximum Likelihood) — A read channel using sampled data, active equalization and Viterbi detection to accurately retrieve the user data off the disk.

RoHS (Restriction of Hazardous Substances) — WD hard drive products manufactured and sold worldwide after June 1, 2006, meet or exceed Restriction of Hazardous Substances (RoHS) compliance requirements as mandated by the RoHS Directive 2011/65/EU.

Rotational Latency — The amount of delay in obtaining information from a disk drive that can be attributed to the rotation of the disk. For a disk rotating at 10,000 RPM, the average latency is 3 milliseconds.

RPM (Revolutions per Minute) — Rotational speed of the media (disk), also known as the spindle speed. Hard drives spin at one constant speed. The slower the RPM, the higher the mechanical latencies. Disk RPM is a critical component of hard drive performance because it directly impacts the rotational latency of the disk transfer rate.

Seek Time — The time it takes for the read/write head to move to a specific block of data on the hard drive. The average seek time is computed by dividing the time it takes to complete a large number of random seeks by the number of seeks performed.

Sector — A 512-byte packet of data.

Self-Monitoring, Analysis, and Reporting Technology (S.M.A.R.T.) — A technology to assist the user in preventing possible system down time due to hard drive failure.

Serial ATA (SATA) — SATA is the industry standard bus interface for hard drives. It is designed to replace Parallel ATA, and has many advantages including increased transfer rate, improved signal integrity, enhanced data protection, and hot plugging.

S.M.A.R.T. Command Transport (SCT) — The SCT Command Transport feature set provides a method for a host to send commands and data to a device and for a device to send data and status to a host using log pages.

Staggered Spinup — SATA feature that allows the system to control whether the drive will spin up immediately or wait until the interface is fully ready.

Unrecoverable Error — A read error that cannot be overcome by an ECC scheme or by rereading the data when host retries are enabled.

World Wide Name (WWN) — The World Wide Name (WWN) defined in ATA/ATAPI-7 is a modification of the IEEE extended unique identifier 64 bit standard (EUI-64) and is comprised of three major components: naming authority, organizationally unique identifier (OUI) and serial number.

INDEX

A

- Acoustics 15
- Active LED Status 9, 24
- Advanced Format 9, 20
- AF 20
- Agency Approvals 16
- Airflow 14
- AllFrame™ 19, 48
- Atmospheric Pressure 15
- ATA Security 9
- Automatic Defect Retirement 23

B

- bytes per sector
 - host 10
 - physical 10

C

- Cabling 15
- Commands
 - SCT 28
- Connectors
 - Serial ATA Latching 43
- Cooling
 - Airflow 14
- Current Requirements 12

D

- Data Lifeguard 22, 48
- Data Surfaces 10
- Defect Management 23
- Dimensions
 - Physical 10
 - Mounting 11
- Dynamic fly height control 20

E

- Environmental 13
- Energy-assisted PMR (ePMR) 20
- Error Recovery Process 23

F

- Fluid Dynamic Bearings (FDB) 9, 24

G

- Glossary 48
- Grounding (Hard Drive) 43

H

- Host Interface Commands 27
 - Identify Device (Drive) 32

Index

- S.M.A.R.T. 21, 25
 - Set Features 40
- Hot Plug Support 24

I

- Input Voltage Requirements 12
- Installation and Setup 41
- Internal Environmental Protection System 22

L

- LED
 - active status 24
- Logical Block Addressing
 - 48-bit 25

M

- Maintenance 44
- Magnetic Recording
 - Two-Dimensional (TDMR) 19
- Model number specification 17
- Mounting
 - Orientation 42
 - Screw Size Limitations 43
- Mounting (Hard Drive) 42

O

- OptiNAND™, 8, 19, 48

N

- Native Command Queuing (NCQ) 9, 20
- NoTouch™ 20

P

- Power Dissipation 12
- Power management 9, 25

R

- Ramp load (NoTouch™) 20
- Recording Method 19
- Reliability features set 22
- Ripple (Voltage) 12
- RoHS (Restriction of Hazardous Substances) 15

S

- S.M.A.R.T. 9, 21, 25
- S.M.A.R.T. Command Transport (SCT) 9, 21
- SATA 6 Gb/s interface 19
- SCT (Smart Command Transport) 21
- SCT commands 28
- SCT feature set
 - temperature reporting 21
 - write same 21
- Security Mode 26
 - Passwords 26
 - Security Levels 26
- Serial ATA Latching Connector 43
- Servo Type 10
- Shock and Vibration 13

Specifications 13
 Electrical 12
 Environmental 13
 Mechanical
 Dimensions 11
 Shock and Vibration 13
 Performance 10
 Physical (Dimensions) 11
 Reliability 16
 Temperature and Humidity 14
Staggered Spinup (Pin11) 24

T

Technical Support 45
 Online Services 45
Temperature and Humidity 14
Third-Party Notices 46
TDMR (Two-dimensional magnetic recording) 19

U

Unpacking 41
 Container Inspection 41
 Drive Removal – Shipping Container 41
 Drive Removal - Static Shielding Bag 42
 Handling Precautions 41
 Moving Precautions 42
User Sectors per Drive 10

W

WDDA 19
World Wide Name (WWN) 24
WWN 9, 24



For service and literature:
support.wdc.com
www.westerndigital.com

D018-001050-000000 Rev 1.0
February 2025

Western Digital
5601 Great Oaks Parkway San
Jose, CA 95119 U.S.A.